

Essential

SERIES

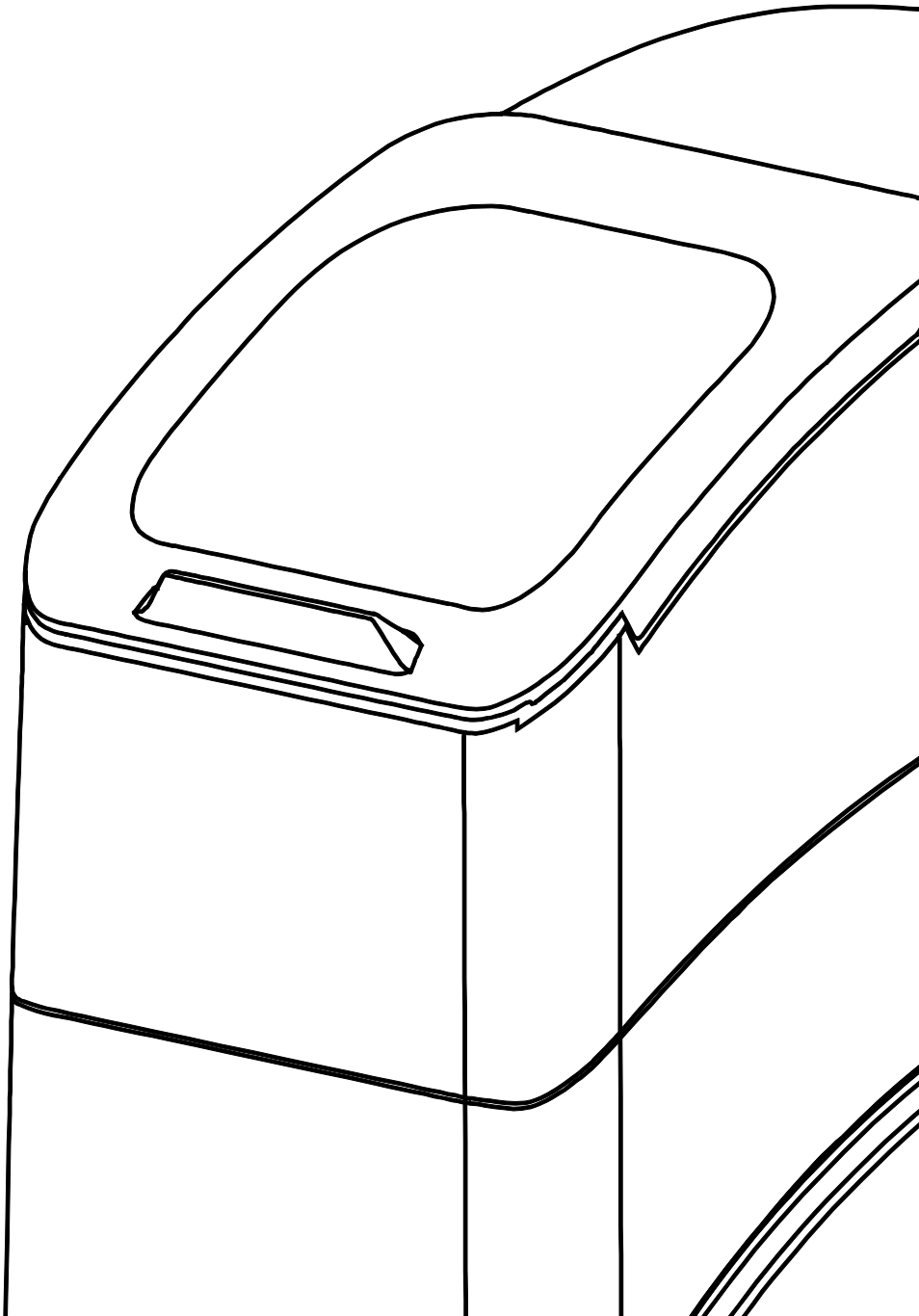

Technical Manual



Model/Product Number:

Essential 8 (15937)

Essential 11 (15988)

Essential 17 (15852)

TABLE OF CONTENTS

About this Manual.....3

Series Overview.....4

System Data Sheets.....5

 Essential 8.....5

 Essential 11.....6

 Essential 17.....7

 Essential Brine Valve Settings.....8

Detailed Operation / Function.....9

 Solitaire Valve Operation.....9

 Level 1 Operation.....9

 Water Metering.....9

 Meter Gearing.....9

 AccuDial® Use Meter.....9

 AccuDial® Meter Reset.....10

 Regeneration Gearing.....10

 Regeneration Control Disc.....10

 Level 3.....10

 Regeneration Flow Control.....10

 Regeneration Nozzle.....10

 Flow Nozzle.....10

 Venturi.....11

 Level 4.....11

 Level 5.....11

 Level 6 / Base.....11

 Media Tank.....12

 Resin.....12

 Upper / Lower Distributors.....12

 Riser Tube.....12

 Brine Tank.....12

 Brine Valve.....12

 Servicing the Venturi.....13

 System Disassembly.....14-17

 Maintenance.....18

 Valve Assembly.....19-20

 AccuDial® Assembly.....21-22

 Setting the AccuDial®.....23

 Manual Regeneration.....23

 Regeneration Sequence.....24-26

 System Components.....27

 In / Out Adapters.....27

 In / Out Adapter Kits.....28

 System By-pass.....28

Troubleshooting.....29-30

Softener Troubleshooting.....31-34

Parts.....35-39

About this Manual

This manual provides additional technical information regarding the Kinetico Essential Series softeners. This additional technical information gives guidance for the advanced service and set-up of these products. This manual will use various icons to help highlight issues that are relevant to the safe operation of this equipment. The following icons will be used as described:



General information regarding the application of this product will be highlighted by this icon. This will include technical specifications and expected operational results.



Maintain safe pressure
This sign indicates the safe operating pressure range.



Consult Maintenance Section
Refer to the maintenance section for specific instructions.



Consult Equipment Specifications Section
Refer to the equipment specifications section for specific instructions.



Consult MSDS Sheets



A caution icon will be used to present any information that may hold a potential hazard or concern during the installation, use or maintenance of this product. Should this information not be followed, it may result in damage to this equipment and its surroundings.



Pinch point or crushing hazard



Chemical hazard



The warning icon will be used to present any information that may result in a severe hazard or concern during the installation, use or maintenance of this product. Should this information not be followed, it may result in severe physical harm.



Stay Clear



Do Not Touch



No Access

Only properly trained and authorized persons can enter area or open panel.



Any tools or materials required during the installation, use or maintenance of this equipment will be preceded by this icon. Using these specific tools will minimize time and effort. Not using the proper tool may result in damage to this equipment, its surroundings or even physical harm.

Series Overview

The Kinetico Essential Series softeners provide soft water for residential applications. The unique design of Kinetico's Solitaire control valve allows for all softener functions to operate automatically and non-electrically.

Service

During the service operation of the Essential, water is being processed by the softener, and the unit will deliver soft water. While the Essential is designed as a compact water softener, its technology base provides for a high efficiency regeneration (over 571 g/kg (4,000 gr/lb) of salt removed, which is the standard for a highly efficient water softener), full flow at a low pressure loss.

By-pass / Regeneration

Since the Essential is a single tank softener, during the regeneration period, the unit cannot make soft water. To alleviate this concern, two design elements are included. First, during a regeneration, the unit automatically by-passes water, so the customer is never without water. Second, the regeneration sequence is designed to operate as quickly as possible. In many cases, this time will be less than 15 minutes for a complete recharge of the system.

AccuDial®

To adjust the regeneration frequency, the Essential uses a variable use meter; this meter is called AccuDial. The AccuDial is intended to be set by an authorized service provider, so the detailed description of this process is not described in the Owner's Manual for the equipment.

Series Range

Three Essential models are available.



| | Essential 8 | Essential 11 | Essential 17 |
|--------------------------|----------------------------|----------------------------|----------------------------|
| Tank Size | 203 mm x 330 mm (8" x 13") | 203 mm x 432 mm (8" x 17") | 203 mm x 610 mm (8" x 24") |
| Service Flow Rate | 30 Lpm (8 gpm) | 36 Lpm (9.5 gpm) | 32 Lpm (8.5 gpm) |
| Resin Type | Fine Mesh | Fine Mesh | Standard Mesh |
| Maximum Hardness | ≤600 mg/L (≤35 gpg) | ≤730 mg/L (≤42 gpg) | ≤967 mg/L (≤56 gpg) |

System Data Sheets

Essential 8

| Design Specifications | | |
|----------------------------------------|---------------------------------|-------------------------|
| Service Flow Rate | 30 Lpm | 8 gpm |
| Flow Rate @ 15 psid | 36 Lpm | 9.5 gpm |
| Pressure Range | 1.7 – 8.6 bar | 25 – 125 psi |
| Temperature Range | 2 – 50 °C | 35 – 120° F |
| Free Chlorine | ≤ 1.0 mg/L | ≤ 1.0 mg/L |
| Compensated Hardness | ≤ 600 mg/L | ≤ 35 gpg |
| Iron (ferrous) | < 0.5 mg/L | < 0.5 mg/L |
| Iron (ferric) | < 0.01 mg/L | < 0.01 mg/L |
| System Components | | |
| Media Vessel (Qty. 1) | 203 mm x 330 mm | 8" x 13" |
| Media Vessel Construction | Fiberglass Wrapped Polyethylene | |
| Empty Bed Volume | 7.4 liters | 0.26 cubic feet |
| Media Type | Fine Mesh Resin | |
| Media Volume (per tank) | 7.4 liters | 0.26 cubic feet |
| Total Bed Depth | 330 mm | 13" |
| Free Board | None | |
| Riser Tube | 27 mm ABS | 1.05" ABS |
| Upper Distributor | 0.18 mm Slots, Cone Type | 0.007" Slots, Cone Type |
| Lower Distributor | 0.18 mm Slots, Cone Type | 0.007" Slots, Cone Type |
| Regeneration Control | Volumetric | |
| Service Flow | Upflow | |
| Regeneration Flow | Downflow | |
| Regeneration Type | Countercurrent | |
| Hard Water By-pass During Regeneration | Automatic | |
| Salt Capacity (Pellet) | 23.6 kg | 52 lbs. |
| System By-pass | Included | |
| Connections | | |
| Inlet / Outlet Connections | Custom Adapter and Bracket | |
| Drain Connection | 0.5" Quick Connect Tubing | |
| Brine Line Connection | 0.375" Quick Connect Tubing | |
| Brine Tank Overflow | 0.625" Tubing Barb | |
| Power | None | |
| System Part Number | | |
| Essential 8 | 15937 | |
| Dimensions and Weight | | |
| Height | 505.5 mm | 19.9 in. |
| Width | 292.1 mm | 11.5 in. |
| Depth | 452.1 mm | 17.8 in. |
| Shipping Weight | 14.5 kg | 32 lbs. |
| Operating Weight | 45.4 kg | 100 lbs. |
| Regeneration Specifications at 35 psi | | |
| Offline Time during Regeneration Cycle | 13.5 minutes | |
| Total Regeneration Cycle Time | 15 minutes | |
| Total Regeneration Volume | 25 liters | 6.6 gallons |
| Salt Used per Regeneration | 0.36 kg | 0.8 lbs. |
| Salt Dose | 49.3 grams NaCl/liter resin | 3.1 lbs./cu. ft. |
| System Capacity | 176 grams | 2,678 grains |
| Backwash Flow Rate | 3.78 Lpm | 1.0 gpm |

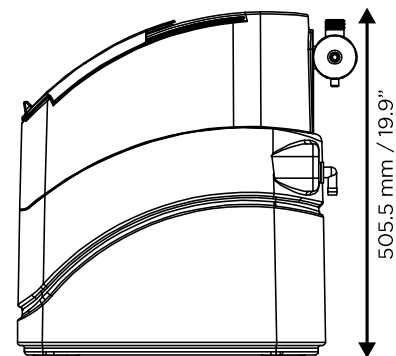
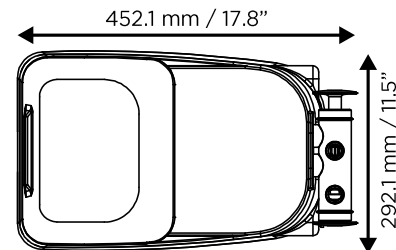
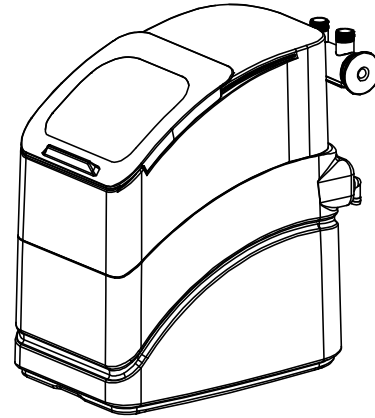

Essential 11

| Design Specifications | | |
|----------------------------------------|---------------------------------|-------------------------|
| Service Flow Rate | 36 Lpm | 9.5 gpm |
| Flow Rate @ 15 psid | 36 Lpm | 9.5 gpm |
| Pressure Range | 1.7 - 8.6 bar | 25 - 125 psi |
| Temperature Range | 2 - 50 °C | 35 - 120° F |
| Free Chlorine | ≤ 1.0 mg/L | ≤ 1.0 mg/L |
| Compensated Hardness | ≤ 730 mg/L | ≤ 42 gpg |
| Iron (ferrous) | < 0.5 mg/L | < 0.5 mg/L |
| Iron (ferric) | < 0.01 mg/L | < 0.01 mg/L |
| System Components | | |
| Media Vessel (Qty. 1) | 203 mm x 432 mm | 8" x 17" |
| Media Vessel Construction | Fiberglass Wrapped Polyethylene | |
| Empty Bed Volume | 10.5 liters | 0.37 cubic feet |
| Media Type | Fine Mesh Resin | |
| Media Volume (per tank) | 10.5 liters | 0.37 cubic feet |
| Total Bed Depth | 432 mm | 17" |
| Free Board | None | |
| Riser Tube | 27 mm ABS | 1.05" ABS |
| Upper Distributor | 0.18 mm Slots, Cone Type | 0.007" Slots, Cone Type |
| Lower Distributor | 0.18 mm Slots, Cone Type | 0.007" Slots, Cone Type |
| Regeneration Control | Volumetric | |
| Service Flow | Upflow | |
| Regeneration Flow | Downflow | |
| Regeneration Type | Countercurrent | |
| Hard Water By-pass During Regeneration | Automatic | |
| Salt Capacity (Pellet) | 30.8 kg | 68 lbs. |
| System By-pass | Included | |
| Connections | | |
| Inlet / Outlet Connections | Custom Adapter and Bracket | |
| Drain Connection | 0.5" Quick Connect Tubing | |
| Brine Line Connection | 0.375" Quick Connect Tubing | |
| Brine Tank Overflow | 0.625" Tubing Barb | |
| Power | None | |
| System Part Number | | |
| Essential 11 | 15988 | |
| Dimensions and Weight | | |
| Height | 607.1 mm | 23.9 in. |
| Width | 297.2 mm | 11.7 in. |
| Depth | 455 mm | 17.9 in. |
| Shipping Weight | 22.7 kg | 50 lbs. |
| Operating Weight | 59.0 kg | 130 lbs. |
| Regeneration Specifications at 35 psi | | |
| Offline Time during Regeneration Cycle | 13.5 minutes | |
| Total Regeneration Cycle Time | 15 minutes | |
| Total Regeneration Volume | 25 liters | 6.6 gallons |
| Salt Used per Regeneration | 0.36 kg | 0.8 lbs. |
| Salt Dose | 33.7 grams NaCl/liter resin | 2.1 lbs./cu. ft. |
| System Capacity | 237 grams | 3,660 grains |
| Backwash Flow Rate | 3.78 Lpm | 1.0 gpm |

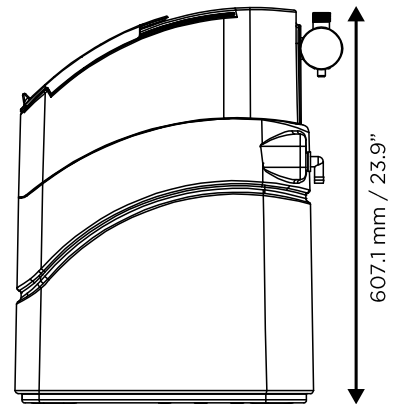
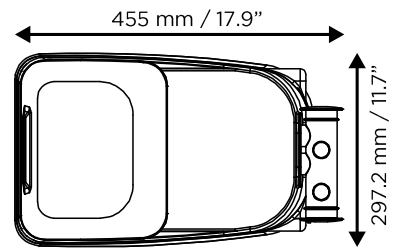
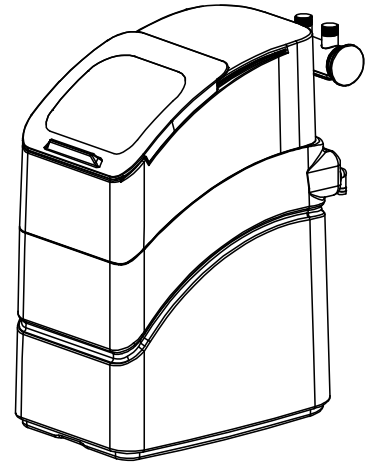

Essential 17

| Design Specifications | | |
|----------------------------------------|---------------------------------|-------------------------|
| Service Flow Rate | 32 Lpm | 8.5 gpm |
| Flow Rate @ 15 psid | 34 Lpm | 9.0 gpm |
| Pressure Range | 1.7 - 8.6 bar | 25 - 125 psi |
| Temperature Range | 2 - 50 °C | 35 - 120° F |
| Free Chlorine | ≤ 1.0 mg/L | ≤ 1.0 mg/L |
| Compensated Hardness | ≤ 967 mg/L | ≤ 56 gpg |
| Iron (ferrous) | < 0.5 mg/L | < 0.5 mg/L |
| Iron (ferric) | < 0.01 mg/L | < 0.01 mg/L |
| System Components | | |
| Media Vessel (Qty. 1) | 203 mm x 610 mm | 8" x 24" |
| Media Vessel Construction | Fiberglass Wrapped Polyethylene | |
| Empty Bed Volume | 16.7 liters | 0.59 cubic feet |
| Media Type | Standard Mesh Resin | |
| Media Volume (per tank) | 16.7 liters | 0.59 cubic feet |
| Total Bed Depth | 610 mm | 24" |
| Free Board | None | |
| Riser Tube | 27 mm ABS | 1.05" ABS |
| Upper Distributor | 0.18 mm Slots, Cone Type | 0.007" Slots, Cone Type |
| Lower Distributor | 0.18 mm Slots, Cone Type | 0.007" Slots, Cone Type |
| Regeneration Control | Volumetric | |
| Service Flow | Upflow | |
| Regeneration Flow | Downflow | |
| Regeneration Type | Countercurrent | |
| Hard Water By-pass During Regeneration | Automatic | |
| Salt Capacity (Pellet) | 49.9 kg | 110 lbs. |
| System By-pass | Included | |
| Connections | | |
| Inlet / Outlet Connections | Custom Adapter and Bracket | |
| Drain Connection | 0.5" Quick Connect Tubing | |
| Brine Line Connection | 0.375" Quick Connect Tubing | |
| Brine Tank Overflow | 0.625" Tubing Barb | |
| Power | None | |
| System Part Number | | |
| Essential 17 | 15852 | |
| Dimensions and Weight | | |
| Height | 785 mm | 30.9 in. |
| Width | 302.3 mm | 11.9 in. |
| Depth | 462.3 mm | 18.2 in. |
| Shipping Weight | 26.8 kg | 59 lbs. |
| Operating Weight | 86.2 kg | 190 lbs. |
| Regeneration Specifications at 35 psi | | |
| Offline Time during Regeneration Cycle | 13.5 minutes | |
| Total Regeneration Cycle Time | 15 minutes | |
| Total Regeneration Volume | 32 liters | 8.5 gallons |
| Salt Used per Regeneration | 0.73 kg | 1.6 lbs. |
| Salt Dose | 43.4 grams NaCl/liter resin | 2.7 lbs./cu. ft. |
| System Capacity | 434 grams | 6,695 grains |
| Backwash Flow Rate | 7.57 Lpm | 2.0 gpm |

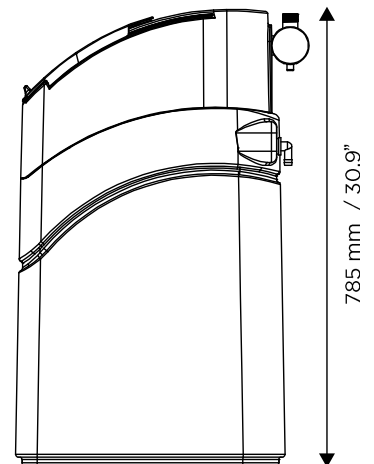
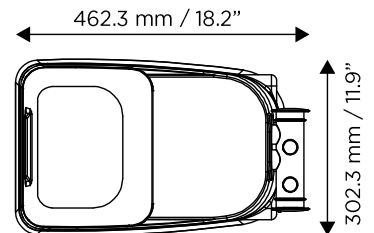
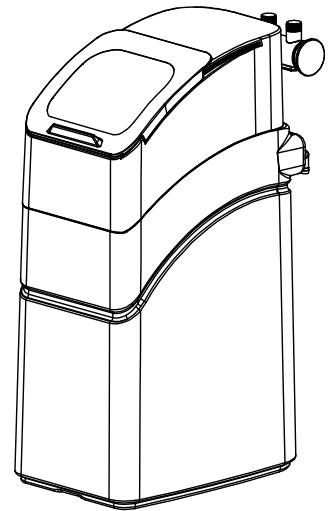

Essential Brine Valve Settings

Essential 8, 11 and 17

These units come with a pre-adjusted brine valve. No additional set-up is required. The float for the Essential 8 and 11 is preset to a 0.36 kg (0.8 lb.) salt setting. The float for the Essential 17 is preset to a 0.73 kg (1.6 lb.) salt setting. This can be confirmed by measuring the distance of the float cup from the top of the fixed adjuster tube. This distance for the Essential 8 and 11 is 12.7 mm (0.5"). The distance for the Essential 17 is 38.1 mm (1.5") (drawing not to scale).

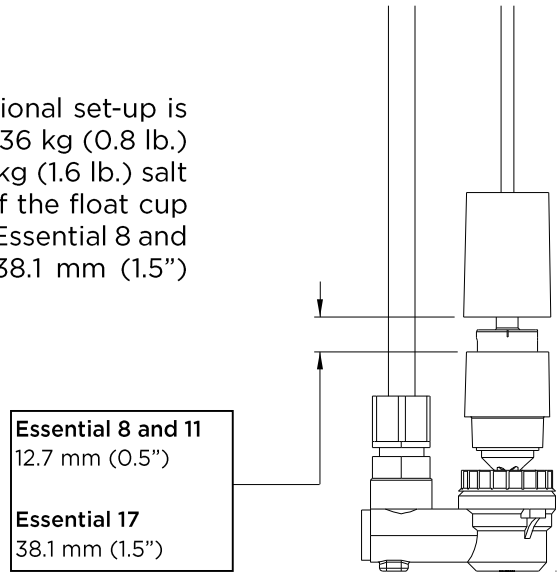

Accudial® Adjustability Charts

| Setting | | A | B | C | D | E | F | ---- | G | ---- | H | - | ---- | - | I | - | ---- | - |
|---------|--|------|------|------|-----|-----|-----|------|-----|------|-----|-----|------|-----|-----|-----|------|-----|
| Liters | | 1240 | 1122 | 1004 | 886 | 768 | 650 | 590 | 531 | 472 | 413 | 394 | 354 | 315 | 295 | 276 | 236 | 197 |
| Gallons | | 328 | 296 | 265 | 234 | 203 | 172 | 156 | 140 | 125 | 109 | 104 | 94 | 83 | 78 | 73 | 62 | 52 |

| | | | | | | | | | | | | | | | | | | | |
|--------------------|----------------------|-----|-----|-----|-----|-----|-----|-----|-----|-----|-----|-----|-----|-----|-----|-----|-----|-----|----------------------------------------------|
| Essential 8 | Comp. Hardness (ppm) | 112 | 124 | 138 | 157 | 180 | 213 | 235 | 262 | 293 | 336 | 352 | 390 | 441 | 470 | 502 | 561 | 600 | CAUTION! DO NOT SET IN BLACK AREA! |
| | Comp. Hardness (°TH) | 11 | 12 | 14 | 16 | 18 | 21 | 23 | 26 | 29 | 34 | 35 | 39 | 44 | 47 | 50 | 56 | 60 | |
| | Comp. Hardness (°dH) | 6 | 7 | 8 | 9 | 10 | 12 | 13 | 15 | 16 | 19 | 20 | 22 | 25 | 26 | 28 | 31 | 34 | |
| | Comp. Hardness (gpg) | 6 | 7 | 8 | 9 | 10 | 12 | 13 | 15 | 17 | 19 | 20 | 22 | 25 | 27 | 29 | 32 | 35 | |

| Setting | | A | B | C | D | E | F | ---- | G | ---- | H | ---- | I | - | ---- | - | J | - | Edge |
|---------|--|------|------|------|------|------|------|------|------|------|-----|------|-----|-----|------|-----|-----|-----|------|
| Liters | | 2385 | 2157 | 1930 | 1703 | 1476 | 1249 | 1136 | 1022 | 908 | 795 | 681 | 568 | 530 | 454 | 379 | 341 | 303 | 227 |
| Gallons | | 630 | 570 | 510 | 450 | 390 | 330 | 300 | 270 | 240 | 210 | 180 | 150 | 140 | 120 | 100 | 90 | 80 | 60 |

| | | | | | | | | | | | | | | | | | | | | |
|---------------------|----------------------|----|----|----|-----|-----|-----|-----|-----|-----|-----|-----|-----|-----|-----|-----|-----|-----|-----|----------------------------------------------|
| Essential 11 | Comp. Hardness (ppm) | 79 | 88 | 98 | 111 | 128 | 152 | 167 | 185 | 209 | 238 | 278 | 334 | 358 | 417 | 501 | 549 | 602 | 730 | CAUTION! DO NOT SET IN BLACK AREA! |
| | Comp. Hardness (°TH) | 8 | 9 | 10 | 11 | 13 | 15 | 17 | 19 | 21 | 24 | 28 | 33 | 36 | 42 | 50 | 55 | 60 | 73 | |
| | Comp. Hardness (°dH) | 4 | 5 | 6 | 6 | 7 | 9 | 9 | 10 | 12 | 13 | 16 | 19 | 20 | 23 | 28 | 31 | 34 | 41 | |
| | Comp. Hardness (gpg) | 4 | 5 | 5 | 6 | 7 | 8 | 9 | 10 | 12 | 13 | 16 | 19 | 20 | 24 | 29 | 32 | 35 | 42 | |

| Setting | | A | B | C | D | E | F | ---- | G | ---- | H | ---- | I | - | ---- | - | J |
|---------|--|------|------|------|------|------|------|------|------|------|-----|------|-----|-----|------|-----|-----|
| Liters | | 2385 | 2157 | 1930 | 1703 | 1476 | 1249 | 1136 | 1022 | 908 | 795 | 681 | 568 | 530 | 454 | 379 | 341 |
| Gallons | | 630 | 570 | 510 | 450 | 390 | 330 | 300 | 270 | 240 | 210 | 180 | 150 | 140 | 120 | 100 | 90 |

| | | | | | | | | | | | | | | | | | | |
|---------------------|----------------------|-----|-----|-----|-----|-----|-----|-----|-----|-----|-----|-----|-----|-----|-----|-----|-----|----------------------------------------------|
| Essential 17 | Comp. Hardness (ppm) | 145 | 161 | 180 | 204 | 235 | 278 | 305 | 339 | 382 | 436 | 509 | 611 | 654 | 763 | 870 | 967 | CAUTION! DO NOT SET IN BLACK AREA! |
| | Comp. Hardness (°TH) | 15 | 16 | 18 | 20 | 23 | 28 | 31 | 34 | 38 | 44 | 51 | 61 | 65 | 76 | 87 | 97 | |
| | Comp. Hardness (°dH) | 8 | 9 | 10 | 11 | 13 | 16 | 17 | 19 | 21 | 24 | 29 | 34 | 37 | 43 | 49 | 54 | |
| | Comp. Hardness (gpg) | 8 | 9 | 10 | 11 | 13 | 16 | 17 | 19 | 22 | 25 | 29 | 35 | 38 | 44 | 50 | 56 | |

Detailed Operation / Function

Solitaire Valve Operation

Kinetico's Essential Series Water Softeners use a simplex tank design. The design allows for completely automatic regeneration, using only the energy from the water pressure to drive all valve functions. Kinetico's simplex valve is called the Kinetico Solitaire™ valve.

1 Level 1
 Level One assembly consists of four chambers: inlet, outlet regeneration and by-pass chambers. Hard water enters the inlet chamber and travels to the media tank where it is treated. Treated water moves from the media tank to the outlet chamber. Contained in the outlet chamber is a water meter turbine, which turns only when water is used. Gears connect the water meter turbine to the water meter disc. The regeneration chamber is an independent chamber, which is only pressurized during the regeneration process. When pressurized, the regeneration flow drives the regeneration gearing, which in turn drives the control disc. The by-pass chamber is situated between the inlet and outlet chambers. During the regeneration process, the by-pass chamber is open, providing a flow connection between inlet and outlet.

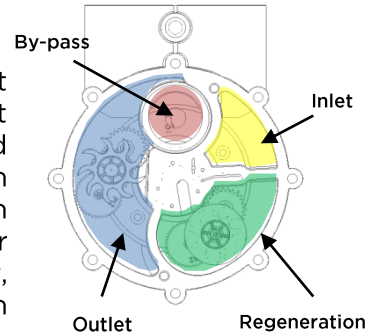

Water Metering

The amount of water metered between a regeneration will be based on three factors: the configuration of the flow nozzle, the selection of the meter gears and the setting of the AccuDial disc. Both the meter gears and AccuDial disc are found as part of the Level 1 assembly.

Meter Gearing

Depending on the model used, the maximum volume of water between regenerations will change. The gear stacks used are listed below:

| Gearing | | | | Standard Nozzle |
|---------|----|----|----|------------------|
| A | B | C | D | Model |
| 12 | 13 | 14 | 20 | Essential 8 |
| 11 | 12 | 13 | 20 | Essential 11, 17 |

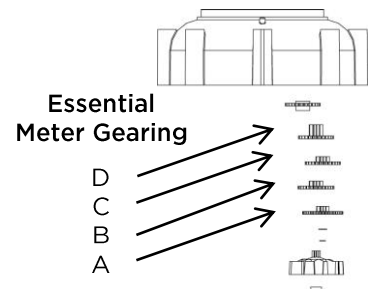

AccuDial® Use Meter

For metering water use, the fully non-electric Solitaire valve includes Kinetico's patented AccuDial® technology. AccuDial provides linear adjustment of metered water volume across a very broad range, allowing the installer to set the system to virtually any desired water use between regenerations, in effect creating a customized system for each individual installation. No special tools or disassembly of the valve are required during set-up, and the setting can be re-adjusted at any time by following the illustrated step-by-step instructions on page 23.

AccuDial® Meter Reset (See Setting the AccuDial Section on page 23 for detailed instructions.)

Resetting the AccuDial meter is simple:

1. Using a Phillips-head screwdriver, manually initiate a system regeneration by depressing and slowly turning the softener valve screw - located in the center of the valve cap - clockwise until four clicks are heard, and water begins to run through the system.
2. Determine AccuDial setting from AccuDial Selection Chart - Locate model number in left-hand column and read across corresponding row to water hardness level; AccuDial setting will be at top of column.
3. With AccuDial mechanism in "home" position (small arrow on disc will be at the six o'clock position), adjust AccuDial to proper setting by pushing down and turning adjustment knob.
4. Set inner numbered disc to desired position. Arrow will be pointing at the center of the numbered box for whole settings. For half settings, arrow will be pointing to the line between boxes.
5. Release adjustment knob and ensure that knob returns to up position.

NOTE: Never set AccuDial with the small arrow pointing anywhere in the black-shaded area on the inner numbered disc. The system will not meter water accurately if set up in this manner.

Regeneration Gearing

The regeneration gearing connects the regeneration turbine to the stem gear and eccentric pin which drives the regeneration drive pawl and advances-the control disc.

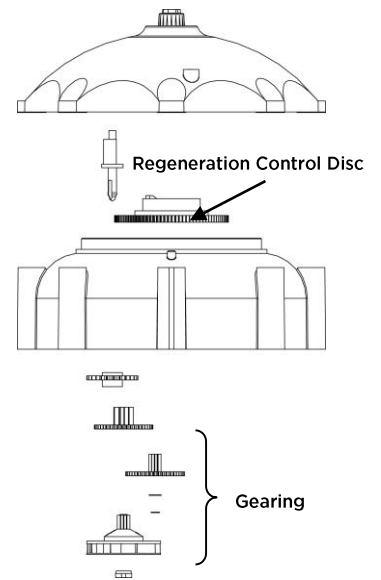

Regeneration Control Disc

All valve positions are controlled by the control disc. As it turns, it covers and uncovers holes in the ceramic disc (located directly below the control disc), sending and receiving pressure signals to open and close all valve pistons.



Level 3

NOTE: The Solitaire valve does not have a level 2.

Level 3 assembly interfaces with the level 1, communicating pressure signals from the control disc and ceramic disc to the valving captured by the levels 3, 4 and 5. In addition to being the pressure communication hub, the Level 3 also contains vital components such as the regeneration flow control, regeneration nozzle, meter flow nozzle and venturi.

Regeneration Flow Control

A 0.76 lpm (0.2 gpm) jet regeneration flow control is used to limit the amount of water sent through the regeneration nozzle.

Regeneration Nozzle

The regeneration nozzle is used to accurately direct the 0.76 lpm (0.2 gpm) flow at the regeneration turbine.

Flow Nozzle

Accuracy and range of the flow meter will depend on the nozzle used with the system. In the Solitaire valve, the flow nozzle is integrated within the level three. The shape of the nozzle is molded in the level 3 and the floor of the nozzle is a feature of the level 4.

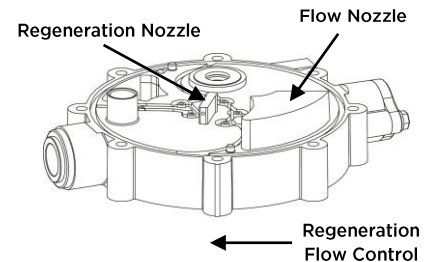

Venturi

The Essential Series Solitaire valve uses a one-piece venturi design to draw brine from the brine drum or cabinet into the resin tank for regeneration of the resin. The design of the Solitaire valve venturi and its location allow for easy access to the venturi and replacement/cleaning if necessary without disassembling the entire Solitaire valve. Refer to the Servicing Venturi Section for details.

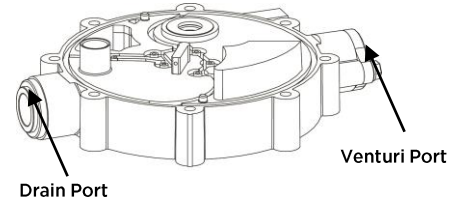

Level 4

The Level 4 contains 5 operating valves. These valves will seal with other levels, but in each case, the valve's shaft is captured in the level 4. These valves include: inlet/by-pass, outlet valve and spring loaded control valve. The servo valves are operated by the control disc. Together these valves control the flow of water through the system during service and regeneration.

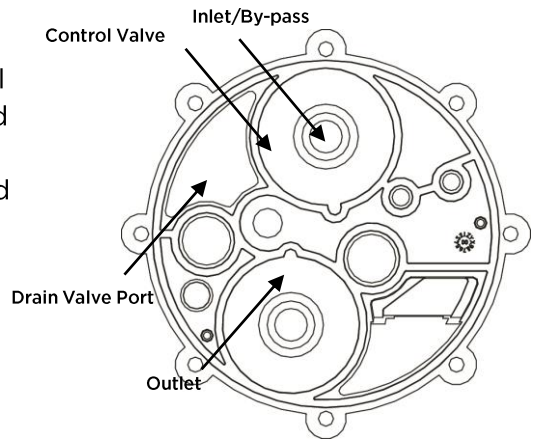

Level 5

The level 5 creates a surface for the valves contained in the level 4 to seal against. It also includes the brine port connection and drain valve.

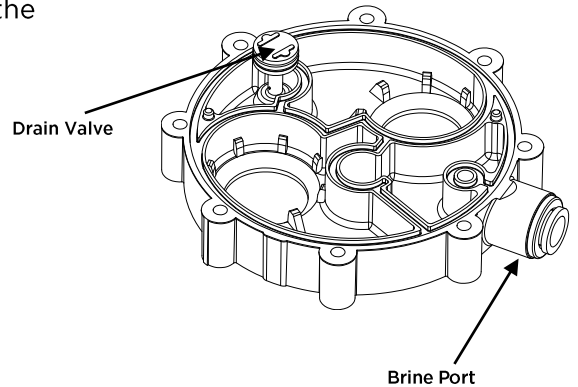

Level 6 / Base

The final level of the valve is used to direct the normal service path of the water. Upflow is the standard flow direction. Since all regenerations are countercurrent, the regeneration direction will be downflow. Also holds the check stem.

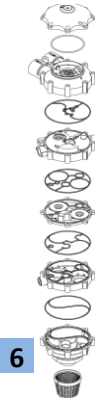
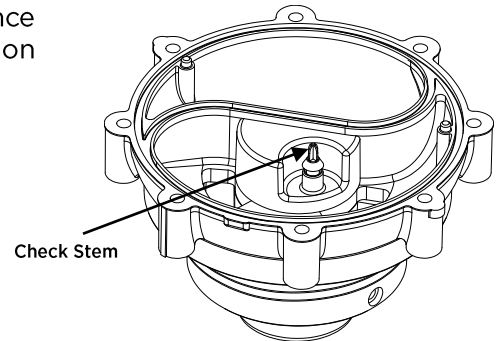

Media Tank

Tank sizes vary from 203 mm x 330 mm (8" x 13") to 203 mm x 610 mm (8" x 24"). These sizes only represent the size of the tank; they do not include the base of the tank. The media tank conforms to NSF standard 61 for components, with a structural performance exceeding 250,000 life cycles when pressurized/depressurized to 10.3 bar (150 psi). The media tank holds the resin which is used for the softening process.

Resin

Each softener uses strong acid, high capacity cation resin, with a minimum exchange capacity of 1.37 eq/L (30,000 gr/cf) when regenerated with a salt dose of 0.24 kg/L (15 lbs/cf).

Upper / Lower Distributors

The distributors prevent channeling of the flow through the resin bed by dispersing the water through the entire radius of the media tank. The distributor also helps maximize the efficiency of the system by improving contact with the resin and minimizing dead spots in the media tank. The design of the distributors also keeps the resin inside the tank as the slots on the distributor are sized smaller than the minimum size of the resin beads.

Riser Tube

A riser tube is used to connect the lower distributor to the control valve. A 1" pipe is used for this connection.

Brine Tank

The brine tank is used for both salt storage and brine production. For some units, the brine tank can also be a cabinet which holds the entire softener. The brine tank is manufactured from corrosion-resistant plastics as the brine makes for a harsh environment.

Brine Valve

A brine valve is used in each brine tank or cabinet. This stops the flow of brine to the control valve when a low level is reached and prevents air from being drawn into the tank. When the bottom check activates, it also marks the beginning of the slow rinse process. The brine valve has a float cup that is used as the high volume level for the brine dose setting, as well as a safety to prevent an overflow situation. There is also an overflow elbow that must be connected to the drain.

Servicing the Venturi

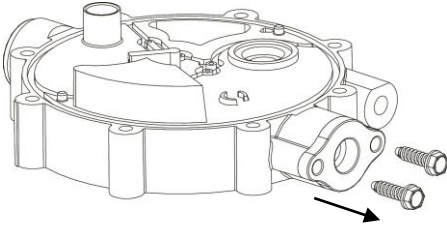
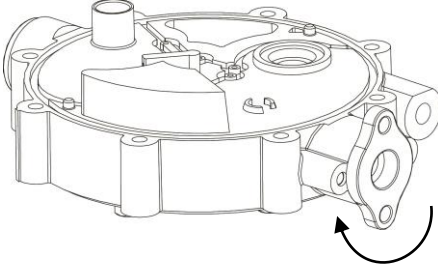
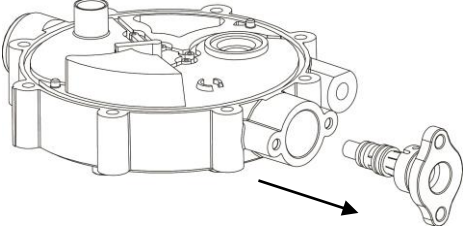
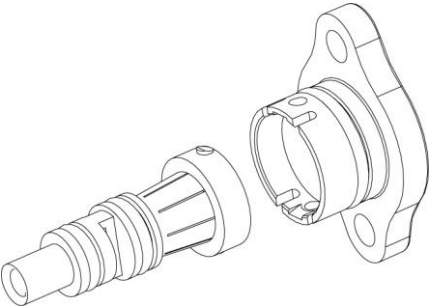
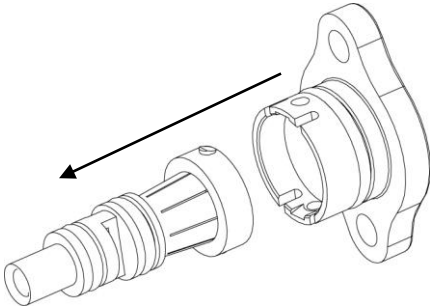
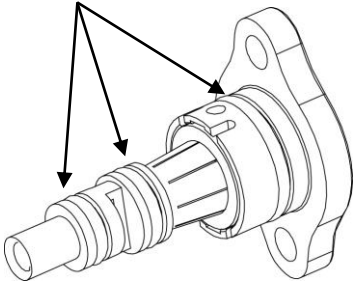
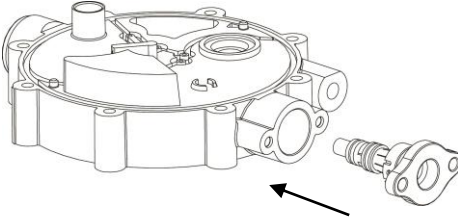
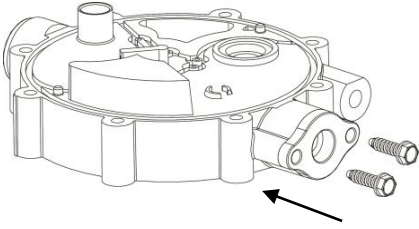
| | | |
|----------------------------------------------------------------------------------------------------------------------------------------------------------------------------------------------------------|--------------------------------------------------------------------------------------------------------------------------------------------------------------------------------------------------------|--------------------------------------------------------------------------------------------------------------------------------------------------|
| <p>1. Remove screws Remove screws using a ¼" nut driver</p>  | <p>2. Twist plug 90°</p>  | <p>3. Pull out venturi/plug assembly</p>  |
| <p>4. Remove venturi Use small screwdriver to pry venturi out of plug (insert screwdriver near tab).</p>  | <p>5. Snap fit new venturi Snap fit in after lining up tabs on venturi with matching holes in plug.</p>  | <p>6. Lubricate O-rings with silicone (3 places)</p>  |
| <p>7. Push venturi/plug back into valve Make sure screw holes on plug align with screw holes on valve</p>  | <p>8. Insert screws Insert screws using a ¼" nut driver</p>  | |

System Disassembly

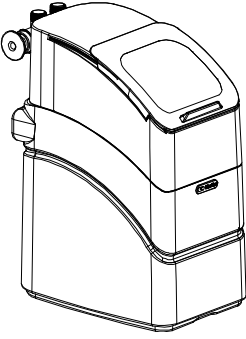
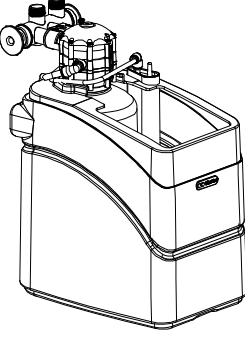
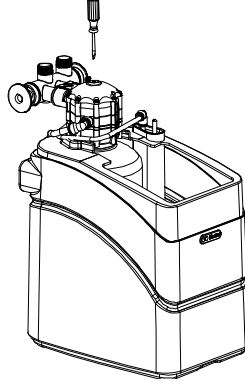
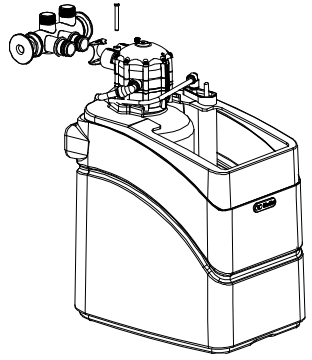
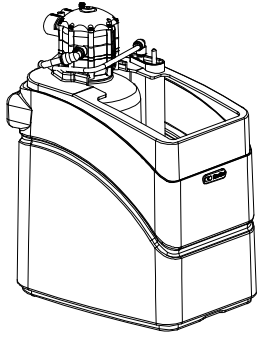
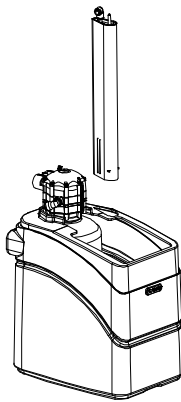
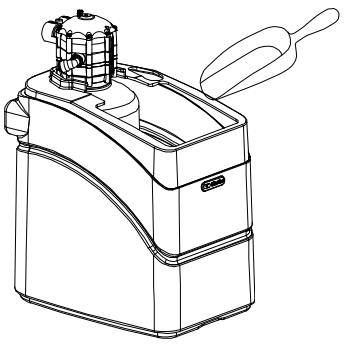
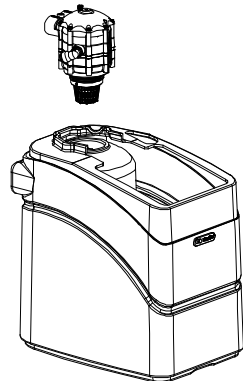
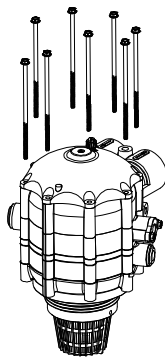
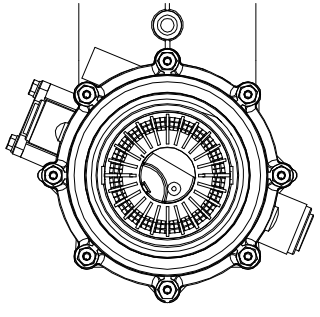
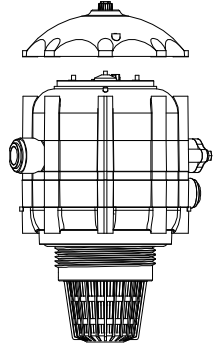
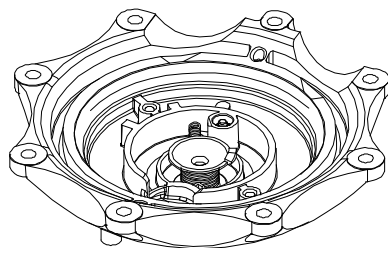
| | | |
|-----------------------------------------------------------------------------------------------------------------------------------|------------------------------------------------------------------------------------------------------------------------------------------|-------------------------------------------------------------------------------------------------------------------------------------------------------------------|
| <p>1. Put unit into by-pass</p>  | <p>2. Remove cover</p>  | <p>3. Depressurize system Depress and turn actuator clockwise.</p>  |
| <p>4. Disconnect and remove by-pass</p>  | <p>5. Disconnect brine line and drain line</p>  | <p>6. Remove brine valve</p>  |
| <p>7. Remove salt</p>  | <p>8. Remove valve</p>  | <p>9. Unbolt valve Unbolt using a 1/4" nut driver.</p>  |
| <p>10. Keep nuts secure to base</p>  | <p>11. Remove Cap</p>  | <p>12. Disassemble cap components</p>  |

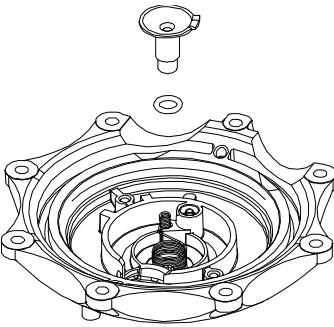
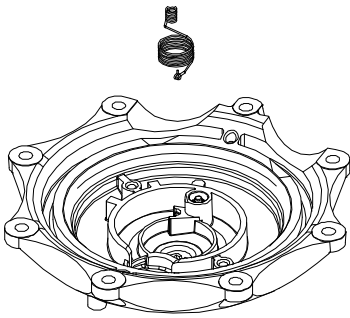
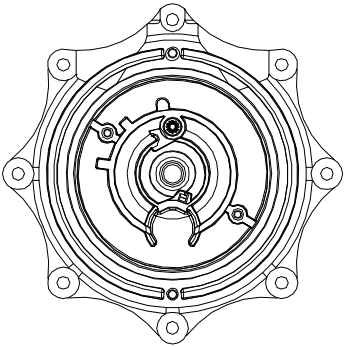
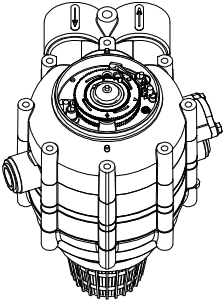
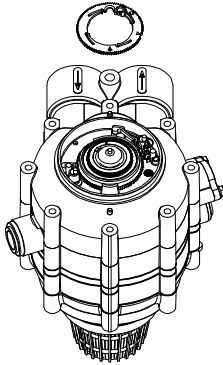
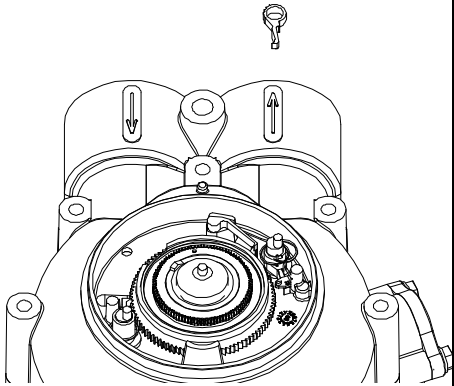
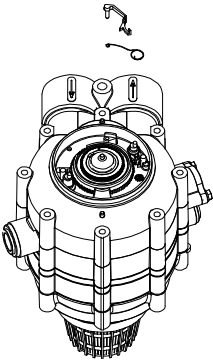
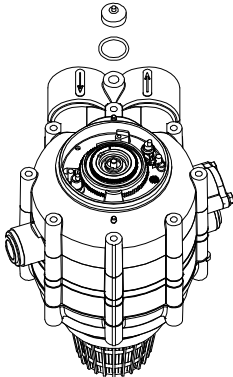
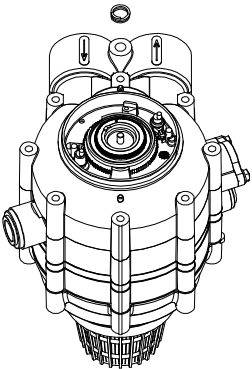
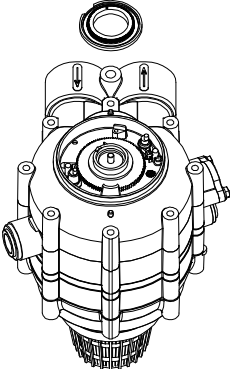
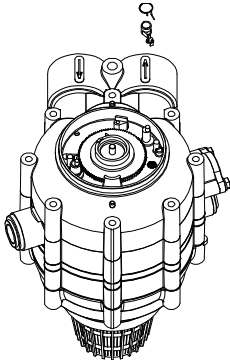
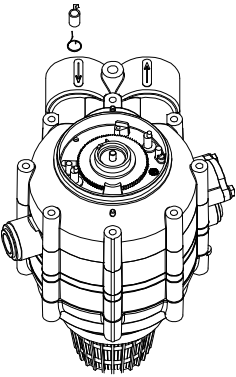
| | | |
|---------------------------------------------------------------------------------------------------------------------------------------------------------------------------------|--------------------------------------------------------------------------------------------------------------------------------------------------|----------------------------------------------------------------------------------------------------------------------------------------------------|
| <p>13. Remove actuator and O-ring</p> <p>Push out using a #2 phillips screwdriver.</p>  | <p>14. Remove reset spring</p>  | <p>15. Inspect cap subassembly</p>  |
| <p>16. Disassemble AccuDial metering</p>  | <p>17. Remove upper disc</p>  | <p>18. Remove meter drive pawl</p>  |
| <p>19. Remove no back pawl and spring</p>  | <p>20. Remove balance piston and O-</p>  | <p>21. Remove balance piston spring</p>  |
| <p>22. Remove lower disc</p>  | <p>23. Remove regeneration start pawl with spring</p>  | <p>24. Remove regeneration drive pawl with spring</p>  |

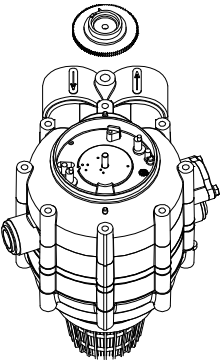
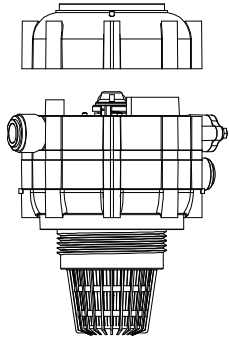
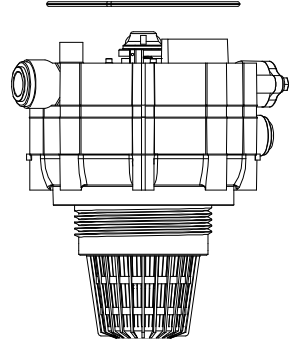
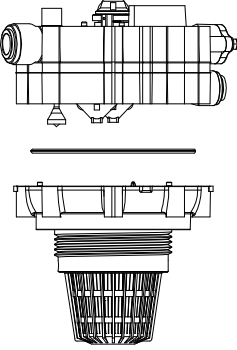
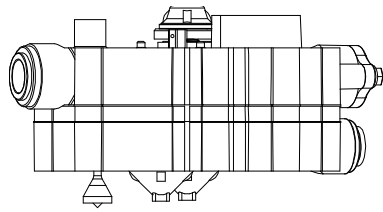
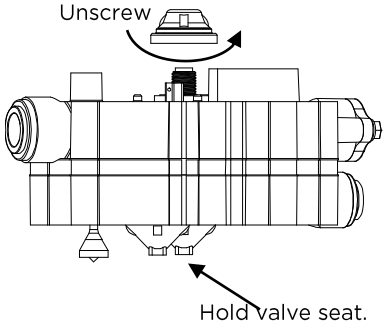
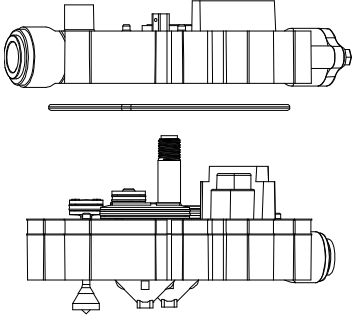
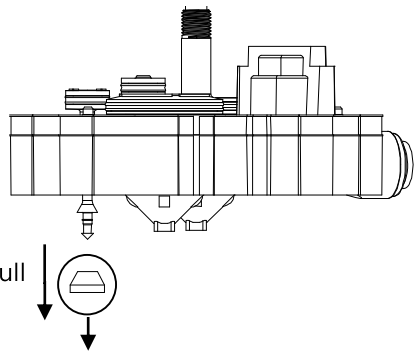
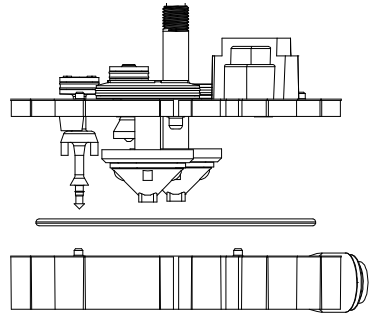
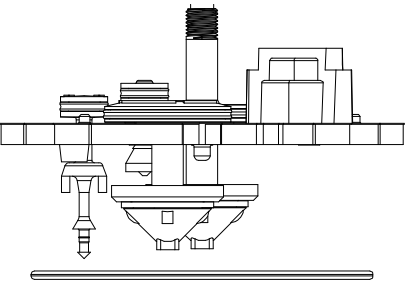
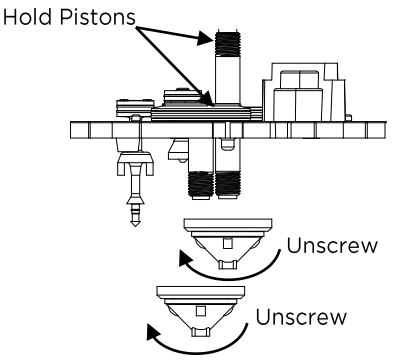
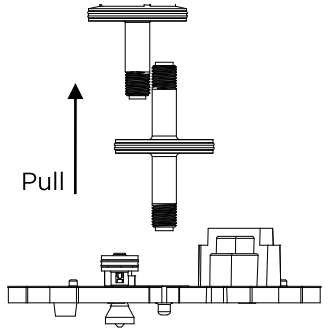
| | | |
|-----------------------------------------------------------------------------------------------------------------------------------------------------------|-------------------------------------------------------------------------------------------------------------------------------------|-----------------------------------------------------------------------------------------------------------------------------------------|
| <p>25. Remove control disc</p>  | <p>26. Remove level 1</p>  | <p>27. Remove level 3 seal</p>  |
| <p>28. Separate level 6, level 6 seal and remove check stem</p>  | <p>29. Isolate level 3-4-5 assembly</p>  | <p>30. Remove by-pass seat</p>  |
| <p>31. Separate level 3 from 4/5 and remove level 3</p>  | <p>32. Remove drain valve seat</p>  | <p>33. Separate level 4 from level 5</p>  |
| <p>34. Remove level 5 seal</p>  | <p>35. Remove inlet and outlet seats</p>  | <p>36. Remove inlet and outlet pistons</p>  |

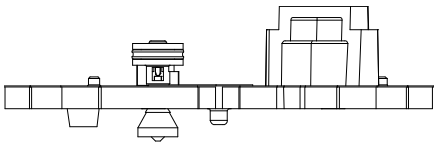
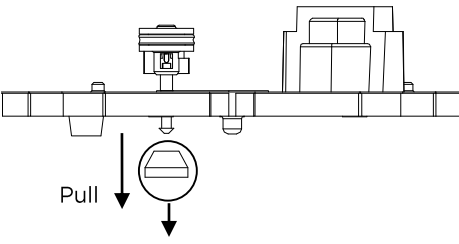
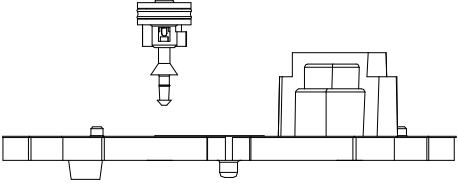
| 37. Remove drain and safety valves | 38. Remove control valve seat | 39. Remove control valve |
|-----------------------------------------------------------------------------------|------------------------------------------------------------------------------------|-------------------------------------------------------------------------------------|
|  |  |  |

Maintenance

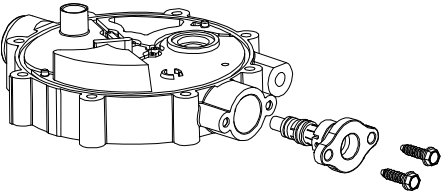
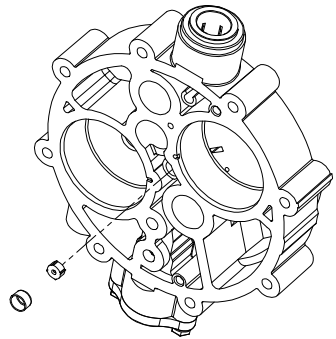
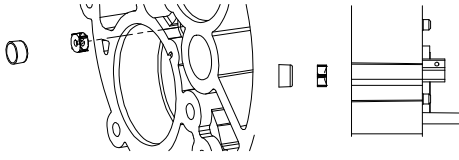
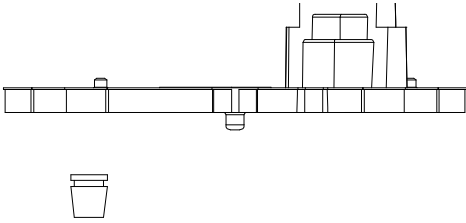
| Service venturi | | |
|---------------------------------------------------------------------------------------------------------------------------|------------------------------------------------------------------------------------------------------------------------------------------------------|--------------------------------------------------------------------------------------|
| <p>Unscrew using a ¼" nut driver.</p>  | | |
| Service regeneration flow control and filter disc | Regeneration flow control orientation | Service backwash flow control |
| <p>Concave side is installed down.</p>  | <p>Concave side is installed down. Then install filter disc.</p>  |  |

Valve Assembly

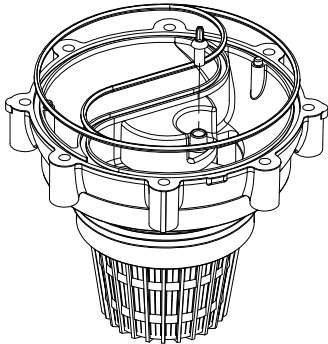
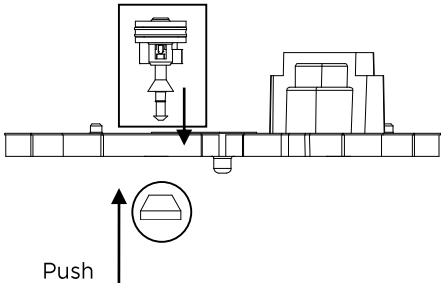
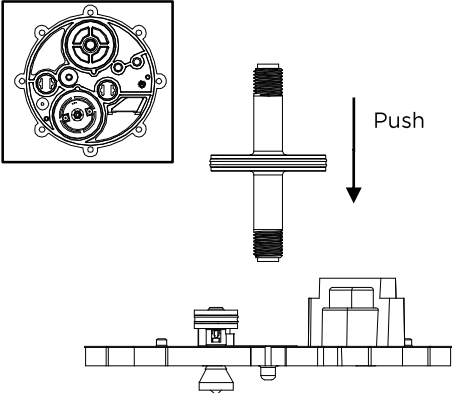
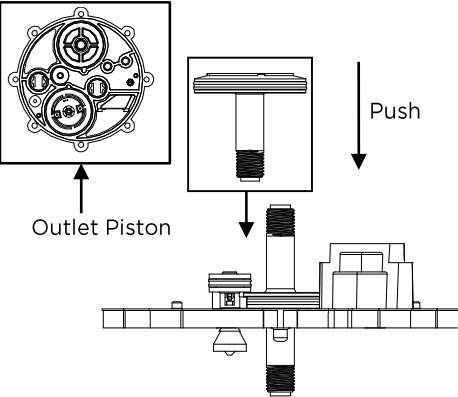
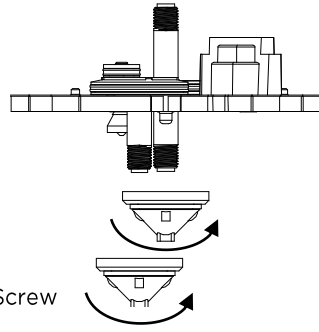
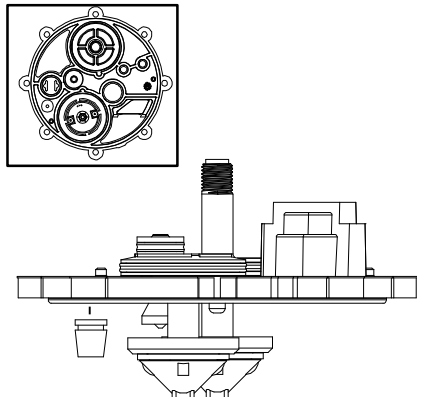
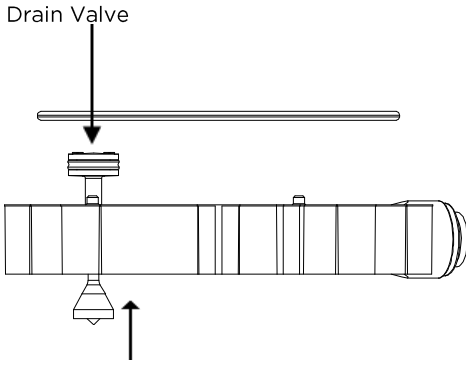
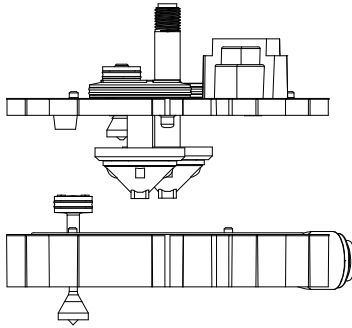
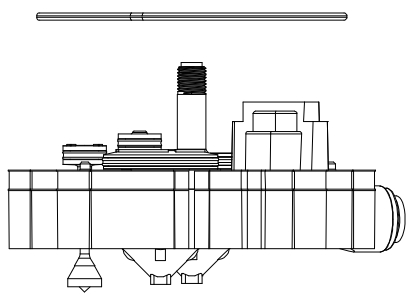
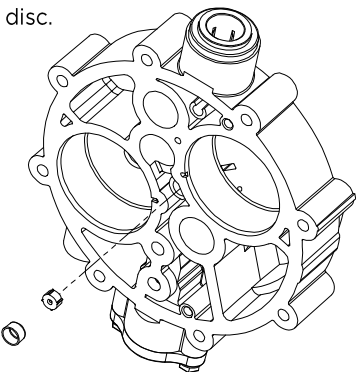
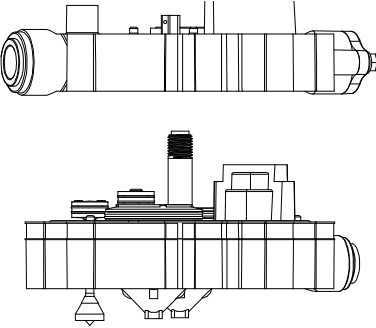
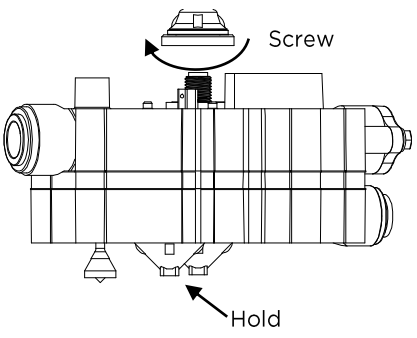
| | | |
|----------------------------------------------------------------------------------------------------------------------------------------------------------------------------------------------------------|--------------------------------------------------------------------------------------------------------------------------------------------|-----------------------------------------------------------------------------------------------------------------------------------------|
| <p>1. Place level 6 seal on level 6 Place in check stem.</p>  | <p>2. Connect control valve to level 4</p>  | <p>3. Insert unitary piston into level 4</p>  |
| <p>4. Insert outlet piston into level 4</p>  | <p>5. Add seats to inlet and outlet valves</p>  | <p>6. Insert BWFC into level 4</p>  |
| <p>7. Place level 5 seal on level 5 Drain Valve</p>  | <p>8. Place level 4 subassembly on level 5</p>  | <p>9. Place level 4 seal on level</p>  |
| <p>10. Insert regen flow control into level Concave side is installed down. Then install filter disc.</p>  | <p>11. Place level 3 on level 4/5</p>  | <p>12. Add by-pass seat</p>  |

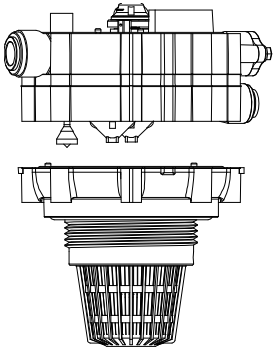
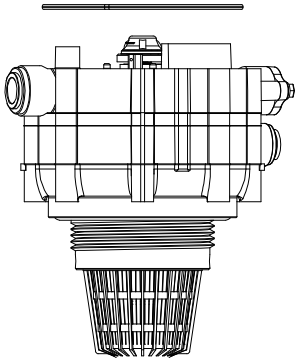
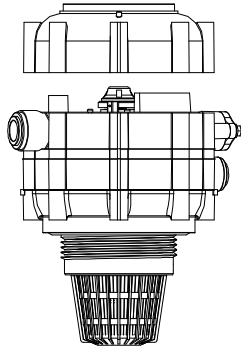
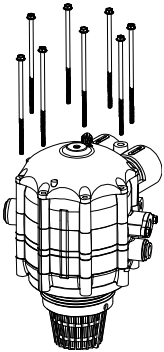
| | | |
|-------------------------------------------------------------------------------------------------------------------------------------------------------------------------------------------------------------------------------|-----------------------------------------------------------------------------------|-------------------------------------------------------------------------------------|
| <p>13. Place 3/4/5 assembly on level 6</p> | <p>14. Place level 3 seal on 3/4/5/6 subassembly</p> | <p>15. Place level 1 assembly on 3/4/5/6</p> |
|  |  |  |
| <p>16. Bolt valve together Use a 1/4" nut driver and tighten to 1.69 Nm (15 in/lbs) in a crossing pattern.</p>  | | |

AccuDial Assembly

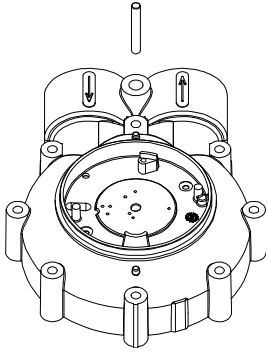
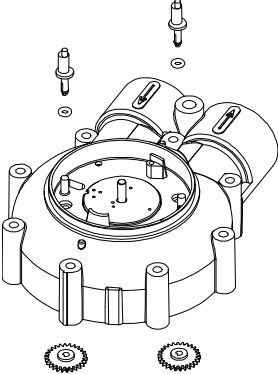
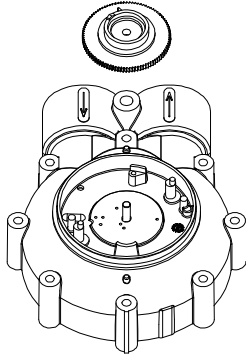
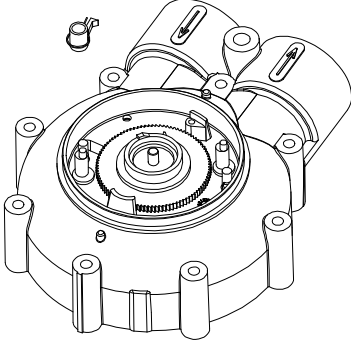
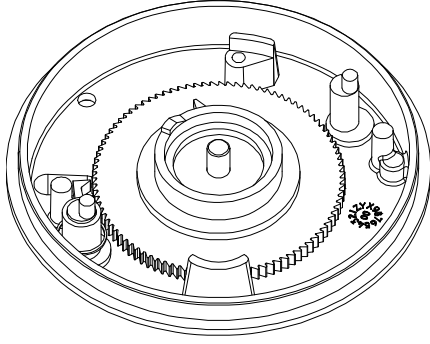
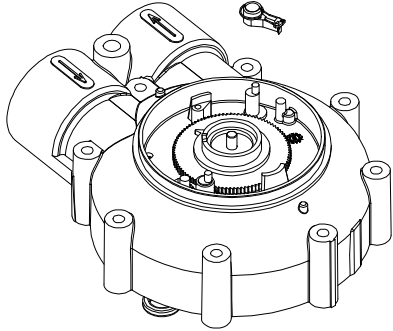
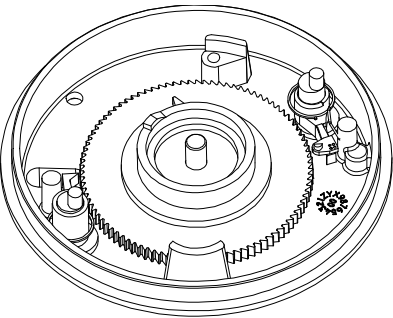
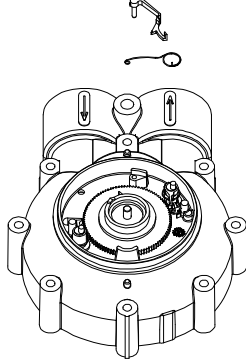
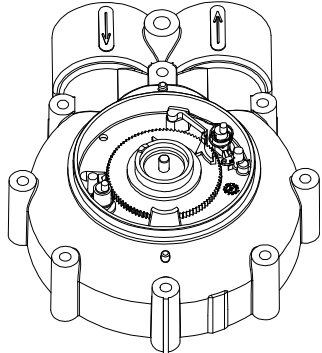
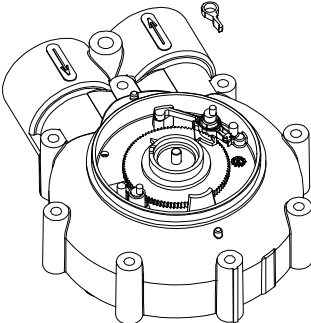
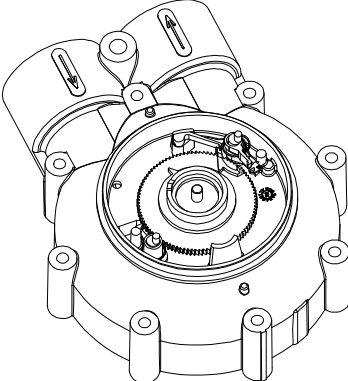
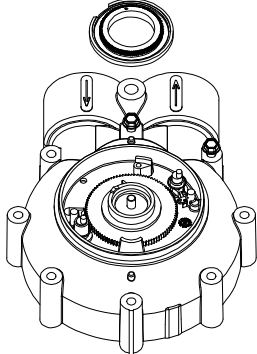
| | | |
|-----------------------------------------------------------------------------------------------------------------------------------------------|-------------------------------------------------------------------------------------|---------------------------------------------------------------------------------------|
| <p>1. Add support pin</p> | <p>2. Add eccentric pins and stem gears</p> | <p>3. Add control disc</p> |
|  |  |  |
| <p>4a. Add regeneration drive pawl with spring</p> | <p>4b. Regeneration drive pawl with spring in place</p> | <p>5a. Add regeneration start pawl with spring</p> |
|  |  |  |
| <p>5b. Regeneration start pawl with spring in place</p> | <p>6a. Add no back pawl and spring</p> | <p>6b. No back pawl and spring added</p> |
|  |  |  |
| <p>7a. Add meter drive pawl</p> | <p>7b. Add meter drive pawl</p> | <p>8. Add lower meter disc</p> |
| <p>Make sure the meter drive pawl catches the spring.</p>  |  |  |

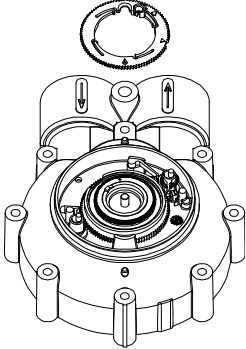
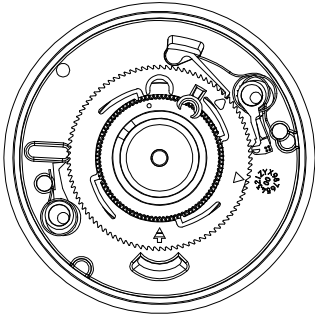
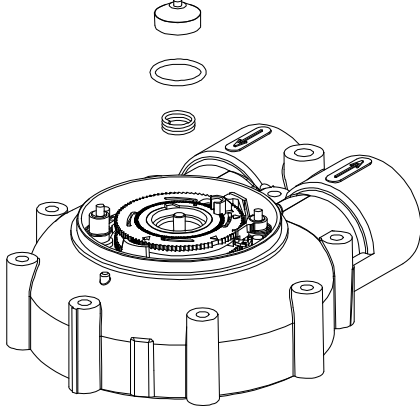
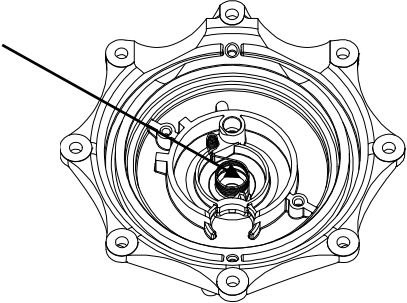
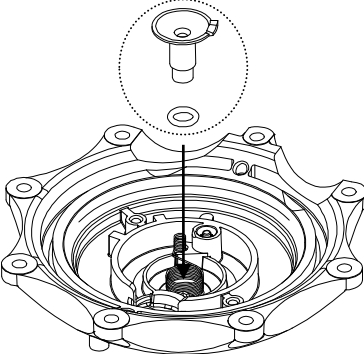
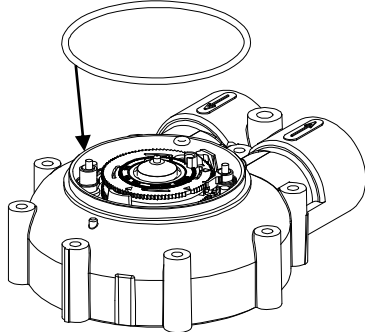
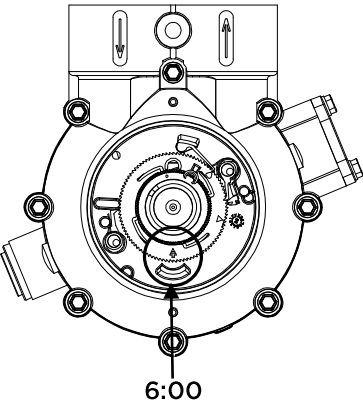
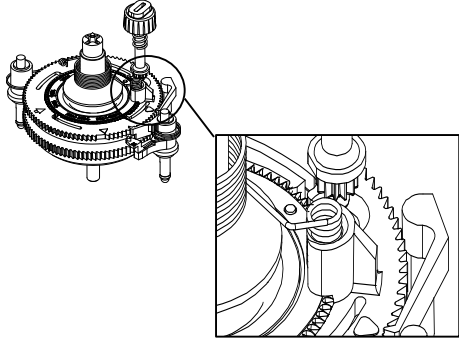
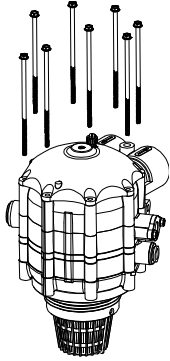
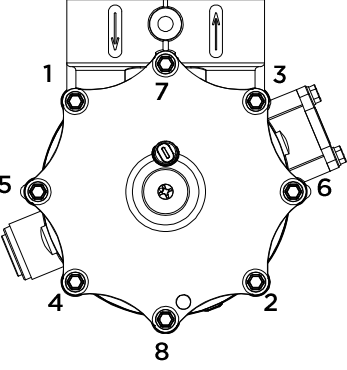
| | | |
|-------------------------------------------------------------------------------------------------------------------------------------------------------------------------------------------|-----------------------------------------------------------------------------------------------------------------------------------------------------------------------------|---------------------------------------------------------------------------------------------------------------------------------------------|
| <p>9a. Add upper meter disc</p> <p>Hold the meter drive pawl back when inserting upper disc.</p>  | <p>9b. Add upper disc</p> <p>Make sure arrow is aligned at 6 o'clock position.</p>  | <p>10. Add balance piston, spring and O-ring</p>  |
| <p>11. Insert return spring into cap</p> | <p>12. Insert actuator and O-ring into cap</p> | <p>13. Add cap O-ring</p> |
|  |  |  |
| <p>14. Align superdisc</p> | <p>15. Attach cap to level 1</p> <p>Make sure the AccuDial reset spring aligns with the upper disc correctly.</p> | <p>16a. Bolt valve</p> <p>Torque the main valve screws to 1.69 Nm (15 in/lbs) in a crossing pattern.</p> |
|  <p>6:00</p> |  |  |
| <p>16b. Bolt valve</p>  | | |

Setting the AccuDial

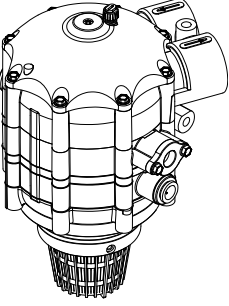
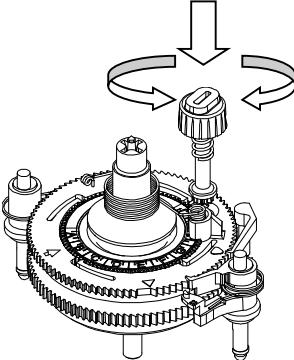
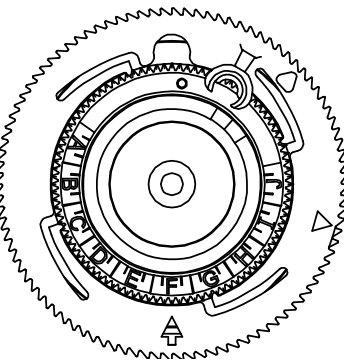
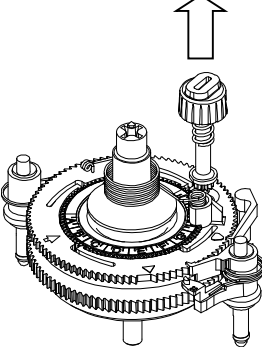
| <p>1. Manually regenerate valve</p> | <p>2. Use disc selection chart to determine setting</p> | <p>3. Adjust AccuDial by pushing and turning knob</p> | | | | | | | | | | | | | | | | | | | | | | | | | | | | | | | | | | | | | | | | | | | | | | | | | | | | | | | | | | | | | | | | | | | | | | | | | | | | | | | | | | | | | | | | | | | | | | | | | | | | | | | | | | | | | | | | | | | | | | | | | | | | | | | | | | | | | | | | | | | | | | | | | | | | | | | | | | | | | | | | | | | | | | | | | | | | | | | | | | | | | | | | | | | | | | | | | | | | | | | | | | | | | | | | | | | | | | | | | | | | | | | | | | | | | | | | | | | | | | | | | | | | | | | | | | | | | | | | | | | | | | | | | | | | | | | | | | | | | | | | | | | | | | | | | | | | | | | | | | | | | | | | | | | | | | | | | | | | | | | | | | | | | | | | | | | | | | | | | | | | | | | | | | | | | | | | | | | | | | | | | | | | | | | | | | | | | | | | | | | | | | | | | | | | | | | | | | | | | | | | | | | | | | | | | | | | | | | | | | | | | | | | | | | | | | | | | | | | | | | | | | | | | | | | | | | | | | | | | | | | | | | | | | | | | | | | | | | | | | | | | | | | | |
|------------------------------------------------------------------------------------|-------------------------------------------------------------------------------------------------------------------------------------------------------------------------------------------------------------------------------------------------------------------------------------------------------------------------------------------------------------------------------------------------------------------------------------------------------------------------------------------------------------------------------------------------------------------------------------------------------------------------------------------------------------------------------------------------------------------------------------------------------------------------------------------------------------------------------------------------------------------------------------------------------------------------------------------------------------------------------------------------------------------------------------------------------------------------------------------------------------------------------------------------------------------------------------------------------------------------------------------------------------------------------------------------------------------------------------------------------------------------------------------------------------------------------------------------------------------------------------------------------------------------------------------------------------------------------------------------------------------------------------------------------------------------------------------------------------------------------------------------------------------------------------------------------------------------------------------------------------------------------------------------------------------------------------------------------------------------------------------------------------------------------------------------------------------------------------------------------------------------------------------------------------------------------------------------------------------------------------------------------------------------------------------------------------------------------------------------------------------------------------------------------------------------------------------------------------------------------------------------------------------------------------------------------------------------------------------------------------------------------------------------------------------------------------------------------------------------------------------------------------------------------------------------------------------------------------------------------------------------------------------------------------------------------------------------------------------------------------------------------------------------------------------------------------------------------------------------------------------------------------------------------------------------------------------------------------------------------------------------------------------------------------------------------------------------------------------------------------------------------------------------------------------------------------------------------------------------------------------------------------------------------------------------------------------------------------------------------------------------------------------------------------------------------------------------------------------------------------------------------------------------------------------------------------------------------------------------------------------------------------------------------------------------------------------------------------------------------------------------------------------------------------------------------------------------------------------------------------------------------------------------------------------------------------------------------------------------------------------------------------------------------------------------------------------------------------------------------------------------------------------------------------------------------------------------------------------------------------------------------------------------------------------------------------------------------------------------------------------------------------------------------------------------------------------------------------------------------------------------------------------------------------------------------------------------------------------------------------------------------------------------------------------------------------------------------------------------------------------------------------------------------------------------------------------------------------------------------------------------------------------------------------------------------------------------------------------------------------------------------------------------------------------------------------------------------------------------------------------------------------------------------------------------------------------------------------------------------------------------------------------------------------------------------------------------------------------------------------------------------------------------------------------------------------------------------------------------------------------------------------------------------------------------------------------------------------------------------------------------------------------------------------------------------------------------------------------------------------------------------------------------------------------------------------------------------------------------------------------------------------------------------------------------------------------------------------------------------------------------------------------------------------------------------------------------------------------------------------------------------------------------------------------------------------------------------------------|--------------------------------------------------------------|------|------|------|------|------|-----|-----|-----|-----|----|---|---|---|---|---|---|---|---|---|---|---|---|---|---|---|---|-------|------|------|------|-----|-----|-----|-----|-----|-----|-----|----|---|---|---|---|---|---|---|---|---|---|---|---|---|---|---|---------|-----|-----|-----|-----|-----|-----|-----|----|---|---|---|---|---|---|---|---|---|---|---|---|---|---|---|---|---|---|------------------------|-----|-----|----|----|----|----|----|----|----|---|---|---|---|---|---|---|---|---|---|---|---|---|---|---|---|---|----------------------|---|---|---|---|---|---|---|---|---|---|---|---|---|---|---|---|---|---|---|---|---|---|---|---|---|---|----------------------|---|---|---|---|---|---|---|---|---|---|---|---|---|---|---|---|---|---|---|---|---|---|---|---|---|---|---------|---|---|---|---|---|---|---|---|---|---|---|---|---|---|---|---|---|---|---|---|---|---|---|---|---|---|-------|------|------|------|------|------|------|------|-----|-----|-----|-----|----|---|---|---|---|---|---|---|---|---|---|---|---|---|---|---------|------|------|------|------|------|-----|-----|-----|-----|-----|----|---|---|---|---|---|---|---|---|---|---|---|---|---|---|---|------------------------|----|----|----|----|----|----|----|---|---|---|---|---|---|---|---|---|---|---|---|---|---|---|---|---|---|---|----------------------|---|---|---|---|---|---|---|---|---|---|---|---|---|---|---|---|---|---|---|---|---|---|---|---|---|---|----------------------|---|---|---|---|---|---|---|---|---|---|---|---|---|---|---|---|---|---|---|---|---|---|---|---|---|---|---------|---|---|---|---|---|---|---|---|---|---|---|---|---|---|---|---|---|---|---|---|---|---|---|---|---|---|-------|------|------|------|------|------|------|------|-----|-----|-----|-----|----|---|---|---|---|---|---|---|---|---|---|---|---|---|---------|------|------|------|------|------|-----|-----|-----|-----|-----|----|---|---|---|---|---|---|---|---|---|---|---|---|---|---|---|------------------------|----|----|----|----|----|----|----|---|---|---|---|---|---|---|---|---|---|---|---|---|---|---|---|---|---|---|----------------------|---|---|---|---|---|---|---|---|---|---|---|---|---|---|---|---|---|---|---|---|---|---|---|---|---|---|----------------------|---|---|---|---|---|---|---|---|---|---|---|---|---|---|---|---|---|---|---|---|---|---|---|---|---|---|-------------------------------------------------------------------------------------|
|  | <p>See page 8 of this tech manual.</p> <p>AccuDial® Adjustability Charts</p> <table border="1"> <thead> <tr> <th>Setting</th> <th>A</th> <th>B</th> <th>C</th> <th>D</th> <th>E</th> <th>F</th> <th>G</th> <th>H</th> <th>I</th> <th>J</th> <th>K</th> <th>L</th> <th>M</th> <th>N</th> <th>O</th> <th>P</th> <th>Q</th> <th>R</th> <th>S</th> <th>T</th> <th>U</th> <th>V</th> <th>W</th> <th>X</th> <th>Y</th> <th>Z</th> </tr> </thead> <tbody> <tr> <td>Lines</td> <td>1240</td> <td>1122</td> <td>1004</td> <td>886</td> <td>768</td> <td>650</td> <td>532</td> <td>414</td> <td>296</td> <td>178</td> <td>60</td> <td>0</td> <td>0</td> <td>0</td> <td>0</td> <td>0</td> <td>0</td> <td>0</td> <td>0</td> <td>0</td> <td>0</td> <td>0</td> <td>0</td> <td>0</td> <td>0</td> <td>0</td> </tr> <tr> <td>Gallons</td> <td>876</td> <td>758</td> <td>640</td> <td>522</td> <td>404</td> <td>286</td> <td>168</td> <td>50</td> <td>0</td> <td>0</td> <td>0</td> <td>0</td> <td>0</td> <td>0</td> <td>0</td> <td>0</td> <td>0</td> <td>0</td> <td>0</td> <td>0</td> <td>0</td> <td>0</td> <td>0</td> <td>0</td> <td>0</td> <td>0</td> </tr> <tr> <td>Comp. Hardness (grain)</td> <td>114</td> <td>102</td> <td>90</td> <td>78</td> <td>66</td> <td>54</td> <td>42</td> <td>30</td> <td>18</td> <td>6</td> <td>0</td> <td>0</td> <td>0</td> <td>0</td> <td>0</td> <td>0</td> <td>0</td> <td>0</td> <td>0</td> <td>0</td> <td>0</td> <td>0</td> <td>0</td> <td>0</td> <td>0</td> <td>0</td> </tr> <tr> <td>Comp. Hardness (°Hd)</td> <td>4</td> <td>3</td> <td>2</td> <td>1</td> <td>0</td> <td>0</td> <td>0</td> <td>0</td> <td>0</td> <td>0</td> <td>0</td> <td>0</td> <td>0</td> <td>0</td> <td>0</td> <td>0</td> <td>0</td> <td>0</td> <td>0</td> <td>0</td> <td>0</td> <td>0</td> <td>0</td> <td>0</td> <td>0</td> <td>0</td> </tr> <tr> <td>Comp. Hardness (ppm)</td> <td>4</td> <td>3</td> <td>2</td> <td>1</td> <td>0</td> <td>0</td> <td>0</td> <td>0</td> <td>0</td> <td>0</td> <td>0</td> <td>0</td> <td>0</td> <td>0</td> <td>0</td> <td>0</td> <td>0</td> <td>0</td> <td>0</td> <td>0</td> <td>0</td> <td>0</td> <td>0</td> <td>0</td> <td>0</td> <td>0</td> </tr> </tbody> </table> <table border="1"> <thead> <tr> <th>Setting</th> <th>A</th> <th>B</th> <th>C</th> <th>D</th> <th>E</th> <th>F</th> <th>G</th> <th>H</th> <th>I</th> <th>J</th> <th>K</th> <th>L</th> <th>M</th> <th>N</th> <th>O</th> <th>P</th> <th>Q</th> <th>R</th> <th>S</th> <th>T</th> <th>U</th> <th>V</th> <th>W</th> <th>X</th> <th>Y</th> <th>Z</th> </tr> </thead> <tbody> <tr> <td>Lines</td> <td>2388</td> <td>2167</td> <td>1946</td> <td>1725</td> <td>1504</td> <td>1283</td> <td>1062</td> <td>841</td> <td>620</td> <td>399</td> <td>178</td> <td>57</td> <td>0</td> <td>0</td> <td>0</td> <td>0</td> <td>0</td> <td>0</td> <td>0</td> <td>0</td> <td>0</td> <td>0</td> <td>0</td> <td>0</td> <td>0</td> <td>0</td> </tr> <tr> <td>Gallons</td> <td>1716</td> <td>1541</td> <td>1366</td> <td>1191</td> <td>1016</td> <td>841</td> <td>666</td> <td>491</td> <td>316</td> <td>141</td> <td>66</td> <td>0</td> <td>0</td> <td>0</td> <td>0</td> <td>0</td> <td>0</td> <td>0</td> <td>0</td> <td>0</td> <td>0</td> <td>0</td> <td>0</td> <td>0</td> <td>0</td> <td>0</td> </tr> <tr> <td>Comp. Hardness (grain)</td> <td>29</td> <td>26</td> <td>23</td> <td>20</td> <td>17</td> <td>14</td> <td>11</td> <td>8</td> <td>5</td> <td>2</td> <td>0</td> <td>0</td> <td>0</td> <td>0</td> <td>0</td> <td>0</td> <td>0</td> <td>0</td> <td>0</td> <td>0</td> <td>0</td> <td>0</td> <td>0</td> <td>0</td> <td>0</td> <td>0</td> </tr> <tr> <td>Comp. Hardness (°Hd)</td> <td>1</td> <td>0</td> <td>0</td> <td>0</td> <td>0</td> <td>0</td> <td>0</td> <td>0</td> <td>0</td> <td>0</td> <td>0</td> <td>0</td> <td>0</td> <td>0</td> <td>0</td> <td>0</td> <td>0</td> <td>0</td> <td>0</td> <td>0</td> <td>0</td> <td>0</td> <td>0</td> <td>0</td> <td>0</td> <td>0</td> </tr> <tr> <td>Comp. Hardness (ppm)</td> <td>1</td> <td>0</td> <td>0</td> <td>0</td> <td>0</td> <td>0</td> <td>0</td> <td>0</td> <td>0</td> <td>0</td> <td>0</td> <td>0</td> <td>0</td> <td>0</td> <td>0</td> <td>0</td> <td>0</td> <td>0</td> <td>0</td> <td>0</td> <td>0</td> <td>0</td> <td>0</td> <td>0</td> <td>0</td> <td>0</td> </tr> </tbody> </table> <table border="1"> <thead> <tr> <th>Setting</th> <th>A</th> <th>B</th> <th>C</th> <th>D</th> <th>E</th> <th>F</th> <th>G</th> <th>H</th> <th>I</th> <th>J</th> <th>K</th> <th>L</th> <th>M</th> <th>N</th> <th>O</th> <th>P</th> <th>Q</th> <th>R</th> <th>S</th> <th>T</th> <th>U</th> <th>V</th> <th>W</th> <th>X</th> <th>Y</th> <th>Z</th> </tr> </thead> <tbody> <tr> <td>Lines</td> <td>2388</td> <td>2167</td> <td>1946</td> <td>1725</td> <td>1504</td> <td>1283</td> <td>1062</td> <td>841</td> <td>620</td> <td>399</td> <td>178</td> <td>57</td> <td>0</td> <td>0</td> <td>0</td> <td>0</td> <td>0</td> <td>0</td> <td>0</td> <td>0</td> <td>0</td> <td>0</td> <td>0</td> <td>0</td> <td>0</td> </tr> <tr> <td>Gallons</td> <td>1716</td> <td>1541</td> <td>1366</td> <td>1191</td> <td>1016</td> <td>841</td> <td>666</td> <td>491</td> <td>316</td> <td>141</td> <td>66</td> <td>0</td> <td>0</td> <td>0</td> <td>0</td> <td>0</td> <td>0</td> <td>0</td> <td>0</td> <td>0</td> <td>0</td> <td>0</td> <td>0</td> <td>0</td> <td>0</td> <td>0</td> </tr> <tr> <td>Comp. Hardness (grain)</td> <td>29</td> <td>26</td> <td>23</td> <td>20</td> <td>17</td> <td>14</td> <td>11</td> <td>8</td> <td>5</td> <td>2</td> <td>0</td> <td>0</td> <td>0</td> <td>0</td> <td>0</td> <td>0</td> <td>0</td> <td>0</td> <td>0</td> <td>0</td> <td>0</td> <td>0</td> <td>0</td> <td>0</td> <td>0</td> <td>0</td> </tr> <tr> <td>Comp. Hardness (°Hd)</td> <td>1</td> <td>0</td> <td>0</td> <td>0</td> <td>0</td> <td>0</td> <td>0</td> <td>0</td> <td>0</td> <td>0</td> <td>0</td> <td>0</td> <td>0</td> <td>0</td> <td>0</td> <td>0</td> <td>0</td> <td>0</td> <td>0</td> <td>0</td> <td>0</td> <td>0</td> <td>0</td> <td>0</td> <td>0</td> <td>0</td> </tr> <tr> <td>Comp. Hardness (ppm)</td> <td>1</td> <td>0</td> <td>0</td> <td>0</td> <td>0</td> <td>0</td> <td>0</td> <td>0</td> <td>0</td> <td>0</td> <td>0</td> <td>0</td> <td>0</td> <td>0</td> <td>0</td> <td>0</td> <td>0</td> <td>0</td> <td>0</td> <td>0</td> <td>0</td> <td>0</td> <td>0</td> <td>0</td> <td>0</td> <td>0</td> </tr> </tbody> </table> | Setting | A | B | C | D | E | F | G | H | I | J | K | L | M | N | O | P | Q | R | S | T | U | V | W | X | Y | Z | Lines | 1240 | 1122 | 1004 | 886 | 768 | 650 | 532 | 414 | 296 | 178 | 60 | 0 | 0 | 0 | 0 | 0 | 0 | 0 | 0 | 0 | 0 | 0 | 0 | 0 | 0 | 0 | Gallons | 876 | 758 | 640 | 522 | 404 | 286 | 168 | 50 | 0 | 0 | 0 | 0 | 0 | 0 | 0 | 0 | 0 | 0 | 0 | 0 | 0 | 0 | 0 | 0 | 0 | 0 | Comp. Hardness (grain) | 114 | 102 | 90 | 78 | 66 | 54 | 42 | 30 | 18 | 6 | 0 | 0 | 0 | 0 | 0 | 0 | 0 | 0 | 0 | 0 | 0 | 0 | 0 | 0 | 0 | 0 | Comp. Hardness (°Hd) | 4 | 3 | 2 | 1 | 0 | 0 | 0 | 0 | 0 | 0 | 0 | 0 | 0 | 0 | 0 | 0 | 0 | 0 | 0 | 0 | 0 | 0 | 0 | 0 | 0 | 0 | Comp. Hardness (ppm) | 4 | 3 | 2 | 1 | 0 | 0 | 0 | 0 | 0 | 0 | 0 | 0 | 0 | 0 | 0 | 0 | 0 | 0 | 0 | 0 | 0 | 0 | 0 | 0 | 0 | 0 | Setting | A | B | C | D | E | F | G | H | I | J | K | L | M | N | O | P | Q | R | S | T | U | V | W | X | Y | Z | Lines | 2388 | 2167 | 1946 | 1725 | 1504 | 1283 | 1062 | 841 | 620 | 399 | 178 | 57 | 0 | 0 | 0 | 0 | 0 | 0 | 0 | 0 | 0 | 0 | 0 | 0 | 0 | 0 | Gallons | 1716 | 1541 | 1366 | 1191 | 1016 | 841 | 666 | 491 | 316 | 141 | 66 | 0 | 0 | 0 | 0 | 0 | 0 | 0 | 0 | 0 | 0 | 0 | 0 | 0 | 0 | 0 | Comp. Hardness (grain) | 29 | 26 | 23 | 20 | 17 | 14 | 11 | 8 | 5 | 2 | 0 | 0 | 0 | 0 | 0 | 0 | 0 | 0 | 0 | 0 | 0 | 0 | 0 | 0 | 0 | 0 | Comp. Hardness (°Hd) | 1 | 0 | 0 | 0 | 0 | 0 | 0 | 0 | 0 | 0 | 0 | 0 | 0 | 0 | 0 | 0 | 0 | 0 | 0 | 0 | 0 | 0 | 0 | 0 | 0 | 0 | Comp. Hardness (ppm) | 1 | 0 | 0 | 0 | 0 | 0 | 0 | 0 | 0 | 0 | 0 | 0 | 0 | 0 | 0 | 0 | 0 | 0 | 0 | 0 | 0 | 0 | 0 | 0 | 0 | 0 | Setting | A | B | C | D | E | F | G | H | I | J | K | L | M | N | O | P | Q | R | S | T | U | V | W | X | Y | Z | Lines | 2388 | 2167 | 1946 | 1725 | 1504 | 1283 | 1062 | 841 | 620 | 399 | 178 | 57 | 0 | 0 | 0 | 0 | 0 | 0 | 0 | 0 | 0 | 0 | 0 | 0 | 0 | Gallons | 1716 | 1541 | 1366 | 1191 | 1016 | 841 | 666 | 491 | 316 | 141 | 66 | 0 | 0 | 0 | 0 | 0 | 0 | 0 | 0 | 0 | 0 | 0 | 0 | 0 | 0 | 0 | Comp. Hardness (grain) | 29 | 26 | 23 | 20 | 17 | 14 | 11 | 8 | 5 | 2 | 0 | 0 | 0 | 0 | 0 | 0 | 0 | 0 | 0 | 0 | 0 | 0 | 0 | 0 | 0 | 0 | Comp. Hardness (°Hd) | 1 | 0 | 0 | 0 | 0 | 0 | 0 | 0 | 0 | 0 | 0 | 0 | 0 | 0 | 0 | 0 | 0 | 0 | 0 | 0 | 0 | 0 | 0 | 0 | 0 | 0 | Comp. Hardness (ppm) | 1 | 0 | 0 | 0 | 0 | 0 | 0 | 0 | 0 | 0 | 0 | 0 | 0 | 0 | 0 | 0 | 0 | 0 | 0 | 0 | 0 | 0 | 0 | 0 | 0 | 0 |  |
| Setting | A | B | C | D | E | F | G | H | I | J | K | L | M | N | O | P | Q | R | S | T | U | V | W | X | Y | Z | | | | | | | | | | | | | | | | | | | | | | | | | | | | | | | | | | | | | | | | | | | | | | | | | | | | | | | | | | | | | | | | | | | | | | | | | | | | | | | | | | | | | | | | | | | | | | | | | | | | | | | | | | | | | | | | | | | | | | | | | | | | | | | | | | | | | | | | | | | | | | | | | | | | | | | | | | | | | | | | | | | | | | | | | | | | | | | | | | | | | | | | | | | | | | | | | | | | | | | | | | | | | | | | | | | | | | | | | | | | | | | | | | | | | | | | | | | | | | | | | | | | | | | | | | | | | | | | | | | | | | | | | | | | | | | | | | | | | | | | | | | | | | | | | | | | | | | | | | | | | | | | | | | | | | | | | | | | | | | | | | | | | | | | | | | | | | | | | | | | | | | | | | | | | | | | | | | | | | | | | | | | | | | | | | | | | | | | | | | | | | | | | | | | | | | | | | | | | | | | | | | | | | | | | | | | | | | | | | | | | | | | | | | | | | | | | | | | | | | | | | | | | | | | | | | | | | | | | | | | | |
| Lines | 1240 | 1122 | 1004 | 886 | 768 | 650 | 532 | 414 | 296 | 178 | 60 | 0 | 0 | 0 | 0 | 0 | 0 | 0 | 0 | 0 | 0 | 0 | 0 | 0 | 0 | 0 | | | | | | | | | | | | | | | | | | | | | | | | | | | | | | | | | | | | | | | | | | | | | | | | | | | | | | | | | | | | | | | | | | | | | | | | | | | | | | | | | | | | | | | | | | | | | | | | | | | | | | | | | | | | | | | | | | | | | | | | | | | | | | | | | | | | | | | | | | | | | | | | | | | | | | | | | | | | | | | | | | | | | | | | | | | | | | | | | | | | | | | | | | | | | | | | | | | | | | | | | | | | | | | | | | | | | | | | | | | | | | | | | | | | | | | | | | | | | | | | | | | | | | | | | | | | | | | | | | | | | | | | | | | | | | | | | | | | | | | | | | | | | | | | | | | | | | | | | | | | | | | | | | | | | | | | | | | | | | | | | | | | | | | | | | | | | | | | | | | | | | | | | | | | | | | | | | | | | | | | | | | | | | | | | | | | | | | | | | | | | | | | | | | | | | | | | | | | | | | | | | | | | | | | | | | | | | | | | | | | | | | | | | | | | | | | | | | | | | | | | | | | | | | | | | | | | | | | | | | | | |
| Gallons | 876 | 758 | 640 | 522 | 404 | 286 | 168 | 50 | 0 | 0 | 0 | 0 | 0 | 0 | 0 | 0 | 0 | 0 | 0 | 0 | 0 | 0 | 0 | 0 | 0 | 0 | | | | | | | | | | | | | | | | | | | | | | | | | | | | | | | | | | | | | | | | | | | | | | | | | | | | | | | | | | | | | | | | | | | | | | | | | | | | | | | | | | | | | | | | | | | | | | | | | | | | | | | | | | | | | | | | | | | | | | | | | | | | | | | | | | | | | | | | | | | | | | | | | | | | | | | | | | | | | | | | | | | | | | | | | | | | | | | | | | | | | | | | | | | | | | | | | | | | | | | | | | | | | | | | | | | | | | | | | | | | | | | | | | | | | | | | | | | | | | | | | | | | | | | | | | | | | | | | | | | | | | | | | | | | | | | | | | | | | | | | | | | | | | | | | | | | | | | | | | | | | | | | | | | | | | | | | | | | | | | | | | | | | | | | | | | | | | | | | | | | | | | | | | | | | | | | | | | | | | | | | | | | | | | | | | | | | | | | | | | | | | | | | | | | | | | | | | | | | | | | | | | | | | | | | | | | | | | | | | | | | | | | | | | | | | | | | | | | | | | | | | | | | | | | | | | | | | | | | | | | | |
| Comp. Hardness (grain) | 114 | 102 | 90 | 78 | 66 | 54 | 42 | 30 | 18 | 6 | 0 | 0 | 0 | 0 | 0 | 0 | 0 | 0 | 0 | 0 | 0 | 0 | 0 | 0 | 0 | 0 | | | | | | | | | | | | | | | | | | | | | | | | | | | | | | | | | | | | | | | | | | | | | | | | | | | | | | | | | | | | | | | | | | | | | | | | | | | | | | | | | | | | | | | | | | | | | | | | | | | | | | | | | | | | | | | | | | | | | | | | | | | | | | | | | | | | | | | | | | | | | | | | | | | | | | | | | | | | | | | | | | | | | | | | | | | | | | | | | | | | | | | | | | | | | | | | | | | | | | | | | | | | | | | | | | | | | | | | | | | | | | | | | | | | | | | | | | | | | | | | | | | | | | | | | | | | | | | | | | | | | | | | | | | | | | | | | | | | | | | | | | | | | | | | | | | | | | | | | | | | | | | | | | | | | | | | | | | | | | | | | | | | | | | | | | | | | | | | | | | | | | | | | | | | | | | | | | | | | | | | | | | | | | | | | | | | | | | | | | | | | | | | | | | | | | | | | | | | | | | | | | | | | | | | | | | | | | | | | | | | | | | | | | | | | | | | | | | | | | | | | | | | | | | | | | | | | | | | | | | | | |
| Comp. Hardness (°Hd) | 4 | 3 | 2 | 1 | 0 | 0 | 0 | 0 | 0 | 0 | 0 | 0 | 0 | 0 | 0 | 0 | 0 | 0 | 0 | 0 | 0 | 0 | 0 | 0 | 0 | 0 | | | | | | | | | | | | | | | | | | | | | | | | | | | | | | | | | | | | | | | | | | | | | | | | | | | | | | | | | | | | | | | | | | | | | | | | | | | | | | | | | | | | | | | | | | | | | | | | | | | | | | | | | | | | | | | | | | | | | | | | | | | | | | | | | | | | | | | | | | | | | | | | | | | | | | | | | | | | | | | | | | | | | | | | | | | | | | | | | | | | | | | | | | | | | | | | | | | | | | | | | | | | | | | | | | | | | | | | | | | | | | | | | | | | | | | | | | | | | | | | | | | | | | | | | | | | | | | | | | | | | | | | | | | | | | | | | | | | | | | | | | | | | | | | | | | | | | | | | | | | | | | | | | | | | | | | | | | | | | | | | | | | | | | | | | | | | | | | | | | | | | | | | | | | | | | | | | | | | | | | | | | | | | | | | | | | | | | | | | | | | | | | | | | | | | | | | | | | | | | | | | | | | | | | | | | | | | | | | | | | | | | | | | | | | | | | | | | | | | | | | | | | | | | | | | | | | | | | | | | | | |
| Comp. Hardness (ppm) | 4 | 3 | 2 | 1 | 0 | 0 | 0 | 0 | 0 | 0 | 0 | 0 | 0 | 0 | 0 | 0 | 0 | 0 | 0 | 0 | 0 | 0 | 0 | 0 | 0 | 0 | | | | | | | | | | | | | | | | | | | | | | | | | | | | | | | | | | | | | | | | | | | | | | | | | | | | | | | | | | | | | | | | | | | | | | | | | | | | | | | | | | | | | | | | | | | | | | | | | | | | | | | | | | | | | | | | | | | | | | | | | | | | | | | | | | | | | | | | | | | | | | | | | | | | | | | | | | | | | | | | | | | | | | | | | | | | | | | | | | | | | | | | | | | | | | | | | | | | | | | | | | | | | | | | | | | | | | | | | | | | | | | | | | | | | | | | | | | | | | | | | | | | | | | | | | | | | | | | | | | | | | | | | | | | | | | | | | | | | | | | | | | | | | | | | | | | | | | | | | | | | | | | | | | | | | | | | | | | | | | | | | | | | | | | | | | | | | | | | | | | | | | | | | | | | | | | | | | | | | | | | | | | | | | | | | | | | | | | | | | | | | | | | | | | | | | | | | | | | | | | | | | | | | | | | | | | | | | | | | | | | | | | | | | | | | | | | | | | | | | | | | | | | | | | | | | | | | | | | | | | | |
| Setting | A | B | C | D | E | F | G | H | I | J | K | L | M | N | O | P | Q | R | S | T | U | V | W | X | Y | Z | | | | | | | | | | | | | | | | | | | | | | | | | | | | | | | | | | | | | | | | | | | | | | | | | | | | | | | | | | | | | | | | | | | | | | | | | | | | | | | | | | | | | | | | | | | | | | | | | | | | | | | | | | | | | | | | | | | | | | | | | | | | | | | | | | | | | | | | | | | | | | | | | | | | | | | | | | | | | | | | | | | | | | | | | | | | | | | | | | | | | | | | | | | | | | | | | | | | | | | | | | | | | | | | | | | | | | | | | | | | | | | | | | | | | | | | | | | | | | | | | | | | | | | | | | | | | | | | | | | | | | | | | | | | | | | | | | | | | | | | | | | | | | | | | | | | | | | | | | | | | | | | | | | | | | | | | | | | | | | | | | | | | | | | | | | | | | | | | | | | | | | | | | | | | | | | | | | | | | | | | | | | | | | | | | | | | | | | | | | | | | | | | | | | | | | | | | | | | | | | | | | | | | | | | | | | | | | | | | | | | | | | | | | | | | | | | | | | | | | | | | | | | | | | | | | | | | | | | | | | | |
| Lines | 2388 | 2167 | 1946 | 1725 | 1504 | 1283 | 1062 | 841 | 620 | 399 | 178 | 57 | 0 | 0 | 0 | 0 | 0 | 0 | 0 | 0 | 0 | 0 | 0 | 0 | 0 | 0 | | | | | | | | | | | | | | | | | | | | | | | | | | | | | | | | | | | | | | | | | | | | | | | | | | | | | | | | | | | | | | | | | | | | | | | | | | | | | | | | | | | | | | | | | | | | | | | | | | | | | | | | | | | | | | | | | | | | | | | | | | | | | | | | | | | | | | | | | | | | | | | | | | | | | | | | | | | | | | | | | | | | | | | | | | | | | | | | | | | | | | | | | | | | | | | | | | | | | | | | | | | | | | | | | | | | | | | | | | | | | | | | | | | | | | | | | | | | | | | | | | | | | | | | | | | | | | | | | | | | | | | | | | | | | | | | | | | | | | | | | | | | | | | | | | | | | | | | | | | | | | | | | | | | | | | | | | | | | | | | | | | | | | | | | | | | | | | | | | | | | | | | | | | | | | | | | | | | | | | | | | | | | | | | | | | | | | | | | | | | | | | | | | | | | | | | | | | | | | | | | | | | | | | | | | | | | | | | | | | | | | | | | | | | | | | | | | | | | | | | | | | | | | | | | | | | | | | | | | | | | |
| Gallons | 1716 | 1541 | 1366 | 1191 | 1016 | 841 | 666 | 491 | 316 | 141 | 66 | 0 | 0 | 0 | 0 | 0 | 0 | 0 | 0 | 0 | 0 | 0 | 0 | 0 | 0 | 0 | | | | | | | | | | | | | | | | | | | | | | | | | | | | | | | | | | | | | | | | | | | | | | | | | | | | | | | | | | | | | | | | | | | | | | | | | | | | | | | | | | | | | | | | | | | | | | | | | | | | | | | | | | | | | | | | | | | | | | | | | | | | | | | | | | | | | | | | | | | | | | | | | | | | | | | | | | | | | | | | | | | | | | | | | | | | | | | | | | | | | | | | | | | | | | | | | | | | | | | | | | | | | | | | | | | | | | | | | | | | | | | | | | | | | | | | | | | | | | | | | | | | | | | | | | | | | | | | | | | | | | | | | | | | | | | | | | | | | | | | | | | | | | | | | | | | | | | | | | | | | | | | | | | | | | | | | | | | | | | | | | | | | | | | | | | | | | | | | | | | | | | | | | | | | | | | | | | | | | | | | | | | | | | | | | | | | | | | | | | | | | | | | | | | | | | | | | | | | | | | | | | | | | | | | | | | | | | | | | | | | | | | | | | | | | | | | | | | | | | | | | | | | | | | | | | | | | | | | | | | | |
| Comp. Hardness (grain) | 29 | 26 | 23 | 20 | 17 | 14 | 11 | 8 | 5 | 2 | 0 | 0 | 0 | 0 | 0 | 0 | 0 | 0 | 0 | 0 | 0 | 0 | 0 | 0 | 0 | 0 | | | | | | | | | | | | | | | | | | | | | | | | | | | | | | | | | | | | | | | | | | | | | | | | | | | | | | | | | | | | | | | | | | | | | | | | | | | | | | | | | | | | | | | | | | | | | | | | | | | | | | | | | | | | | | | | | | | | | | | | | | | | | | | | | | | | | | | | | | | | | | | | | | | | | | | | | | | | | | | | | | | | | | | | | | | | | | | | | | | | | | | | | | | | | | | | | | | | | | | | | | | | | | | | | | | | | | | | | | | | | | | | | | | | | | | | | | | | | | | | | | | | | | | | | | | | | | | | | | | | | | | | | | | | | | | | | | | | | | | | | | | | | | | | | | | | | | | | | | | | | | | | | | | | | | | | | | | | | | | | | | | | | | | | | | | | | | | | | | | | | | | | | | | | | | | | | | | | | | | | | | | | | | | | | | | | | | | | | | | | | | | | | | | | | | | | | | | | | | | | | | | | | | | | | | | | | | | | | | | | | | | | | | | | | | | | | | | | | | | | | | | | | | | | | | | | | | | | | | | | | |
| Comp. Hardness (°Hd) | 1 | 0 | 0 | 0 | 0 | 0 | 0 | 0 | 0 | 0 | 0 | 0 | 0 | 0 | 0 | 0 | 0 | 0 | 0 | 0 | 0 | 0 | 0 | 0 | 0 | 0 | | | | | | | | | | | | | | | | | | | | | | | | | | | | | | | | | | | | | | | | | | | | | | | | | | | | | | | | | | | | | | | | | | | | | | | | | | | | | | | | | | | | | | | | | | | | | | | | | | | | | | | | | | | | | | | | | | | | | | | | | | | | | | | | | | | | | | | | | | | | | | | | | | | | | | | | | | | | | | | | | | | | | | | | | | | | | | | | | | | | | | | | | | | | | | | | | | | | | | | | | | | | | | | | | | | | | | | | | | | | | | | | | | | | | | | | | | | | | | | | | | | | | | | | | | | | | | | | | | | | | | | | | | | | | | | | | | | | | | | | | | | | | | | | | | | | | | | | | | | | | | | | | | | | | | | | | | | | | | | | | | | | | | | | | | | | | | | | | | | | | | | | | | | | | | | | | | | | | | | | | | | | | | | | | | | | | | | | | | | | | | | | | | | | | | | | | | | | | | | | | | | | | | | | | | | | | | | | | | | | | | | | | | | | | | | | | | | | | | | | | | | | | | | | | | | | | | | | | | | | | |
| Comp. Hardness (ppm) | 1 | 0 | 0 | 0 | 0 | 0 | 0 | 0 | 0 | 0 | 0 | 0 | 0 | 0 | 0 | 0 | 0 | 0 | 0 | 0 | 0 | 0 | 0 | 0 | 0 | 0 | | | | | | | | | | | | | | | | | | | | | | | | | | | | | | | | | | | | | | | | | | | | | | | | | | | | | | | | | | | | | | | | | | | | | | | | | | | | | | | | | | | | | | | | | | | | | | | | | | | | | | | | | | | | | | | | | | | | | | | | | | | | | | | | | | | | | | | | | | | | | | | | | | | | | | | | | | | | | | | | | | | | | | | | | | | | | | | | | | | | | | | | | | | | | | | | | | | | | | | | | | | | | | | | | | | | | | | | | | | | | | | | | | | | | | | | | | | | | | | | | | | | | | | | | | | | | | | | | | | | | | | | | | | | | | | | | | | | | | | | | | | | | | | | | | | | | | | | | | | | | | | | | | | | | | | | | | | | | | | | | | | | | | | | | | | | | | | | | | | | | | | | | | | | | | | | | | | | | | | | | | | | | | | | | | | | | | | | | | | | | | | | | | | | | | | | | | | | | | | | | | | | | | | | | | | | | | | | | | | | | | | | | | | | | | | | | | | | | | | | | | | | | | | | | | | | | | | | | | | | | |
| Setting | A | B | C | D | E | F | G | H | I | J | K | L | M | N | O | P | Q | R | S | T | U | V | W | X | Y | Z | | | | | | | | | | | | | | | | | | | | | | | | | | | | | | | | | | | | | | | | | | | | | | | | | | | | | | | | | | | | | | | | | | | | | | | | | | | | | | | | | | | | | | | | | | | | | | | | | | | | | | | | | | | | | | | | | | | | | | | | | | | | | | | | | | | | | | | | | | | | | | | | | | | | | | | | | | | | | | | | | | | | | | | | | | | | | | | | | | | | | | | | | | | | | | | | | | | | | | | | | | | | | | | | | | | | | | | | | | | | | | | | | | | | | | | | | | | | | | | | | | | | | | | | | | | | | | | | | | | | | | | | | | | | | | | | | | | | | | | | | | | | | | | | | | | | | | | | | | | | | | | | | | | | | | | | | | | | | | | | | | | | | | | | | | | | | | | | | | | | | | | | | | | | | | | | | | | | | | | | | | | | | | | | | | | | | | | | | | | | | | | | | | | | | | | | | | | | | | | | | | | | | | | | | | | | | | | | | | | | | | | | | | | | | | | | | | | | | | | | | | | | | | | | | | | | | | | | | | | | | |
| Lines | 2388 | 2167 | 1946 | 1725 | 1504 | 1283 | 1062 | 841 | 620 | 399 | 178 | 57 | 0 | 0 | 0 | 0 | 0 | 0 | 0 | 0 | 0 | 0 | 0 | 0 | 0 | | | | | | | | | | | | | | | | | | | | | | | | | | | | | | | | | | | | | | | | | | | | | | | | | | | | | | | | | | | | | | | | | | | | | | | | | | | | | | | | | | | | | | | | | | | | | | | | | | | | | | | | | | | | | | | | | | | | | | | | | | | | | | | | | | | | | | | | | | | | | | | | | | | | | | | | | | | | | | | | | | | | | | | | | | | | | | | | | | | | | | | | | | | | | | | | | | | | | | | | | | | | | | | | | | | | | | | | | | | | | | | | | | | | | | | | | | | | | | | | | | | | | | | | | | | | | | | | | | | | | | | | | | | | | | | | | | | | | | | | | | | | | | | | | | | | | | | | | | | | | | | | | | | | | | | | | | | | | | | | | | | | | | | | | | | | | | | | | | | | | | | | | | | | | | | | | | | | | | | | | | | | | | | | | | | | | | | | | | | | | | | | | | | | | | | | | | | | | | | | | | | | | | | | | | | | | | | | | | | | | | | | | | | | | | | | | | | | | | | | | | | | | | | | | | | | | | | | | | | | | | |
| Gallons | 1716 | 1541 | 1366 | 1191 | 1016 | 841 | 666 | 491 | 316 | 141 | 66 | 0 | 0 | 0 | 0 | 0 | 0 | 0 | 0 | 0 | 0 | 0 | 0 | 0 | 0 | 0 | | | | | | | | | | | | | | | | | | | | | | | | | | | | | | | | | | | | | | | | | | | | | | | | | | | | | | | | | | | | | | | | | | | | | | | | | | | | | | | | | | | | | | | | | | | | | | | | | | | | | | | | | | | | | | | | | | | | | | | | | | | | | | | | | | | | | | | | | | | | | | | | | | | | | | | | | | | | | | | | | | | | | | | | | | | | | | | | | | | | | | | | | | | | | | | | | | | | | | | | | | | | | | | | | | | | | | | | | | | | | | | | | | | | | | | | | | | | | | | | | | | | | | | | | | | | | | | | | | | | | | | | | | | | | | | | | | | | | | | | | | | | | | | | | | | | | | | | | | | | | | | | | | | | | | | | | | | | | | | | | | | | | | | | | | | | | | | | | | | | | | | | | | | | | | | | | | | | | | | | | | | | | | | | | | | | | | | | | | | | | | | | | | | | | | | | | | | | | | | | | | | | | | | | | | | | | | | | | | | | | | | | | | | | | | | | | | | | | | | | | | | | | | | | | | | | | | | | | | | | | |
| Comp. Hardness (grain) | 29 | 26 | 23 | 20 | 17 | 14 | 11 | 8 | 5 | 2 | 0 | 0 | 0 | 0 | 0 | 0 | 0 | 0 | 0 | 0 | 0 | 0 | 0 | 0 | 0 | 0 | | | | | | | | | | | | | | | | | | | | | | | | | | | | | | | | | | | | | | | | | | | | | | | | | | | | | | | | | | | | | | | | | | | | | | | | | | | | | | | | | | | | | | | | | | | | | | | | | | | | | | | | | | | | | | | | | | | | | | | | | | | | | | | | | | | | | | | | | | | | | | | | | | | | | | | | | | | | | | | | | | | | | | | | | | | | | | | | | | | | | | | | | | | | | | | | | | | | | | | | | | | | | | | | | | | | | | | | | | | | | | | | | | | | | | | | | | | | | | | | | | | | | | | | | | | | | | | | | | | | | | | | | | | | | | | | | | | | | | | | | | | | | | | | | | | | | | | | | | | | | | | | | | | | | | | | | | | | | | | | | | | | | | | | | | | | | | | | | | | | | | | | | | | | | | | | | | | | | | | | | | | | | | | | | | | | | | | | | | | | | | | | | | | | | | | | | | | | | | | | | | | | | | | | | | | | | | | | | | | | | | | | | | | | | | | | | | | | | | | | | | | | | | | | | | | | | | | | | | | | | |
| Comp. Hardness (°Hd) | 1 | 0 | 0 | 0 | 0 | 0 | 0 | 0 | 0 | 0 | 0 | 0 | 0 | 0 | 0 | 0 | 0 | 0 | 0 | 0 | 0 | 0 | 0 | 0 | 0 | 0 | | | | | | | | | | | | | | | | | | | | | | | | | | | | | | | | | | | | | | | | | | | | | | | | | | | | | | | | | | | | | | | | | | | | | | | | | | | | | | | | | | | | | | | | | | | | | | | | | | | | | | | | | | | | | | | | | | | | | | | | | | | | | | | | | | | | | | | | | | | | | | | | | | | | | | | | | | | | | | | | | | | | | | | | | | | | | | | | | | | | | | | | | | | | | | | | | | | | | | | | | | | | | | | | | | | | | | | | | | | | | | | | | | | | | | | | | | | | | | | | | | | | | | | | | | | | | | | | | | | | | | | | | | | | | | | | | | | | | | | | | | | | | | | | | | | | | | | | | | | | | | | | | | | | | | | | | | | | | | | | | | | | | | | | | | | | | | | | | | | | | | | | | | | | | | | | | | | | | | | | | | | | | | | | | | | | | | | | | | | | | | | | | | | | | | | | | | | | | | | | | | | | | | | | | | | | | | | | | | | | | | | | | | | | | | | | | | | | | | | | | | | | | | | | | | | | | | | | | | | | | |
| Comp. Hardness (ppm) | 1 | 0 | 0 | 0 | 0 | 0 | 0 | 0 | 0 | 0 | 0 | 0 | 0 | 0 | 0 | 0 | 0 | 0 | 0 | 0 | 0 | 0 | 0 | 0 | 0 | 0 | | | | | | | | | | | | | | | | | | | | | | | | | | | | | | | | | | | | | | | | | | | | | | | | | | | | | | | | | | | | | | | | | | | | | | | | | | | | | | | | | | | | | | | | | | | | | | | | | | | | | | | | | | | | | | | | | | | | | | | | | | | | | | | | | | | | | | | | | | | | | | | | | | | | | | | | | | | | | | | | | | | | | | | | | | | | | | | | | | | | | | | | | | | | | | | | | | | | | | | | | | | | | | | | | | | | | | | | | | | | | | | | | | | | | | | | | | | | | | | | | | | | | | | | | | | | | | | | | | | | | | | | | | | | | | | | | | | | | | | | | | | | | | | | | | | | | | | | | | | | | | | | | | | | | | | | | | | | | | | | | | | | | | | | | | | | | | | | | | | | | | | | | | | | | | | | | | | | | | | | | | | | | | | | | | | | | | | | | | | | | | | | | | | | | | | | | | | | | | | | | | | | | | | | | | | | | | | | | | | | | | | | | | | | | | | | | | | | | | | | | | | | | | | | | | | | | | | | | | | | | |
| <p>4. Align arrow to setting</p> | <p>5. Make sure knob is up after setting AccuDial</p> | | | | | | | | | | | | | | | | | | | | | | | | | | | | | | | | | | | | | | | | | | | | | | | | | | | | | | | | | | | | | | | | | | | | | | | | | | | | | | | | | | | | | | | | | | | | | | | | | | | | | | | | | | | | | | | | | | | | | | | | | | | | | | | | | | | | | | | | | | | | | | | | | | | | | | | | | | | | | | | | | | | | | | | | | | | | | | | | | | | | | | | | | | | | | | | | | | | | | | | | | | | | | | | | | | | | | | | | | | | | | | | | | | | | | | | | | | | | | | | | | | | | | | | | | | | | | | | | | | | | | | | | | | | | | | | | | | | | | | | | | | | | | | | | | | | | | | | | | | | | | | | | | | | | | | | | | | | | | | | | | | | | | | | | | | | | | | | | | | | | | | | | | | | | | | | | | | | | | | | | | | | | | | | | | | | | | | | | | | | | | | | | | | | | | | | | | | | | | | | | | | | | | | | | | | | | | | | | | | | | | | | | | | | | | | | | | | | | | | | | | | | | | | | | | | | | | | | | | | | | | | | | | | | | | | | | | | | | | | | | | | | | | | |
|  |  | | | | | | | | | | | | | | | | | | | | | | | | | | | | | | | | | | | | | | | | | | | | | | | | | | | | | | | | | | | | | | | | | | | | | | | | | | | | | | | | | | | | | | | | | | | | | | | | | | | | | | | | | | | | | | | | | | | | | | | | | | | | | | | | | | | | | | | | | | | | | | | | | | | | | | | | | | | | | | | | | | | | | | | | | | | | | | | | | | | | | | | | | | | | | | | | | | | | | | | | | | | | | | | | | | | | | | | | | | | | | | | | | | | | | | | | | | | | | | | | | | | | | | | | | | | | | | | | | | | | | | | | | | | | | | | | | | | | | | | | | | | | | | | | | | | | | | | | | | | | | | | | | | | | | | | | | | | | | | | | | | | | | | | | | | | | | | | | | | | | | | | | | | | | | | | | | | | | | | | | | | | | | | | | | | | | | | | | | | | | | | | | | | | | | | | | | | | | | | | | | | | | | | | | | | | | | | | | | | | | | | | | | | | | | | | | | | | | | | | | | | | | | | | | | | | | | | | | | | | | | | | | | | | | | | | | | | | | | | | | | | | | | | |

Manual Regeneration

Using a #2 Phillips screwdriver, push down firmly on the softener valve screw and slowly turn clockwise, listening for four (4) clicks to start the regeneration. At this point, you should hear water begin to run through the system. If you do not hear water running through the system, the disc has not been advanced far enough.

NOTE: The hot water tank has refilled with hard water, it may take several days for it to empty and for the customer's water to feel soft again.









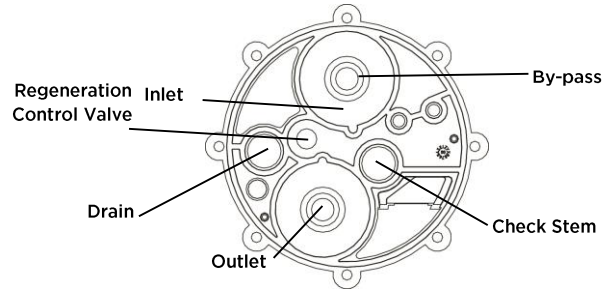

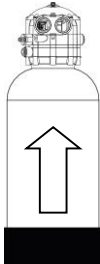
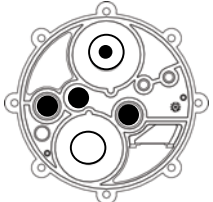





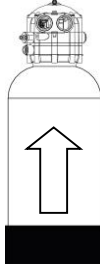
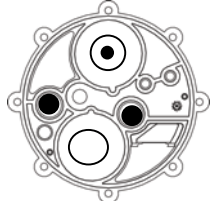





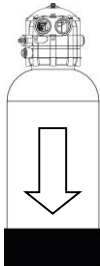
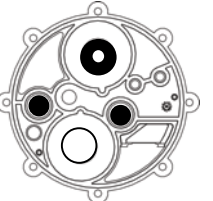



Regeneration Sequence

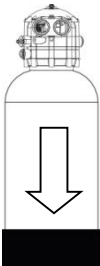
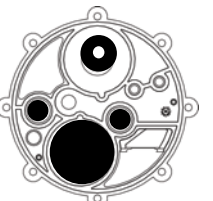







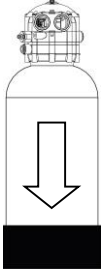
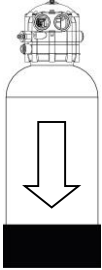
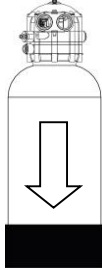
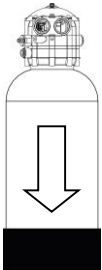
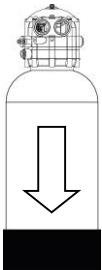





Key for valve positions

-  Open
-  Closed
-  Indicates Service
-  Indicates By-pass

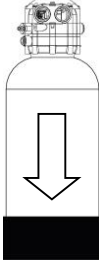
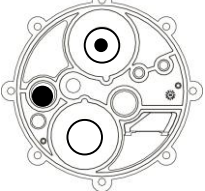



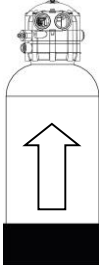
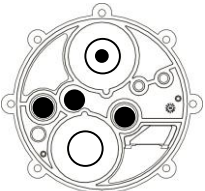

| Valve Position | Inlet/ Bypass | Outlet | Control | Check Stem | Drain |
|-----------------------------------------------------------------------------------------------------------------------------------------------------------------------------------------------------------------------------------------------------------------------------------------------------------------------------------------------------------------------------------------------------------------------------------------------------------|---------------------------------------------------------------------------------------|---------------------------------------------------------------------------------------|---------------------------------------------------------------------------------------|---------------------------------------------------------------------------------------|---------------------------------------------------------------------------------------|
| <p>Service</p>  <p>When the Solitaire valve is in service, the inlet/by-pass valve is open to the inlet position and the outlet valve is open. The control, safety and drain valves are closed. Hard water flows down the central distributor tube and up through the resin bed.</p>  |  |  |  |  |  |
| <p>Control Flow</p>  <p>When the set point volume has metered through the Solitaire valve (determined by the hardness setting on the AccuDial), the control valve opens to drive a regeneration.</p>  |  |  |  |  |  |
| <p>Open By-pass / Close Inlet</p>  <p>In the first step in a regeneration, the inlet/by-pass valve shifts to the by-pass position to allow hard water to by-pass the softener while it is in regeneration.</p>  |  |  |  |  |  |
| <p>Isolate</p>  <p>During the isolation step, the outlet valve closes.</p>  |  |  |  |  |  |

| Valve Position Key: | | Inlet/ Bypass | Outlet | Control | Check Stem | Drain |
|-----------------------------------------------------------------------------------------------------------------------------------------------------------------------------------------------------------------------------------------------------------------------------------------------------------------------------------------------------------------------------------------------------------------------------------------------------------------|--|------------------|--------|---------|---------------|-------|
| Open Closed Indicates Service Indicates By-pass | | | | | | |
| Vent  <p>During the vent step, the drain valve opens up and check stem unchecks</p> | | | | | | |
|  <p>In the brine draw step, the check stem is opens, and brine is drawn by the venturi into the resin bed. Brine flows down through the resin from the top of the tank to the lower distributor and up the central distributor tube. Then, the brine flows out the drain valve to the drain line.</p> | | | | | | |
| Slow Rinse  <p>During slow rinse, there is no change in the position of the internal valves in the Solitaire valve. If the saturated brine in the cabinet or brine drum is drawn down far enough, then the air check on the brine valve checks, and a slow rinse of water begins. The slow rinse flows down through the resin and lasts until backwash begins.</p> | | | | | | |
| Backwash  <p>The backwash step begins when the outlet valve opens up. Backwash is downflow through the resin and rinses the excess brine out of the resin bed.</p> | | | | | | |
| Stop Backwash  <p>After backwash, the drain valve closes.</p> | | | | | | |

| Valve Position Key: | | Inlet/ Bypass | Outlet | Control | Check Stem | Drain |
|-----------------------------------------------------------------------------------------------------------------------------------------------------------------------------------------------------------------------------------------------------------------------------------------------------------------------------------------------------------------------------------------|-------------------------------------------------------------------------------------|-------------------------------------------------------------------------------------|-------------------------------------------------------------------------------------|-------------------------------------------------------------------------------------|-------------------------------------------------------------------------------------|-------------------------------------------------------------------------------------|
|  Open  Closed  Indicates Service  Indicates By-pass | | | | | | |
| Open Inlet / Close By-Pass | |  |  |  |  |  |
|  <p>During the open inlet/close by-pass step, the inlet/by-pass valve switches to the inlet position. During this step, the brine line is pressurized and the cabinet/brine drum is refilled through both the nozzle and throat sides of the venturi.</p> |  | | | | | |
| Service | |  |  |  |  |  |
|  <p>Finally, the Solitaire valve goes back into service when the control valve shuts and the check stem checks. The brine line is always pressurized.</p> |  | | | | | |

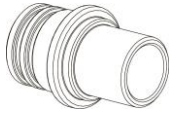
System Components

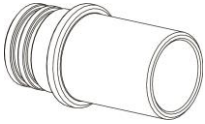
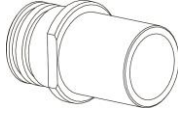

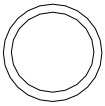
In / Out Adapters

| Part and Part No. | Description | Part and Part No. | Description |
|-------------------------------------------------------------------------------------------------|--------------------------------------------|--------------------------------------------------------------------------------------------------|----------------------------------------------------------------------------------------------------------------------------------------|
|  1355 | BASS IN/OUT ADAPTER - 3/4" - 1" SWEAT |  10081B | STRAIGHT THREAD IN/OUT ADAPTER - 3/4" (straight thread, can be used with hose connection, do not use with NPT fittings) |
|  7841 | BASS IN/OUT ADAPTER - 1" - 1 1/4" SWEAT |  5335D | PVC IN/OUT ADAPTER - 1" GLUE |
|  10169 | COTTERLESS CLEVIS PIN |  7840A | IN/OUT ADAPTER BRACKET |
|  1328 | O-RING IN/OUT ADAPTER | | |

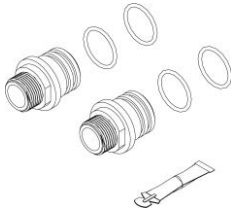
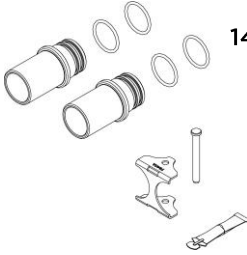
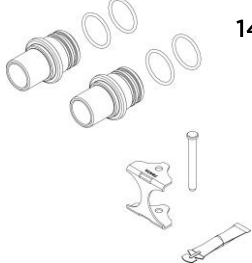
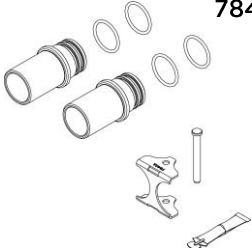
In / Out Adapter Kits

| Part and Part No. | Description | Part and Part No. | Description |
|-------------------------------------------------------------------------------------------------------|-----------------------------------------------------------|--------------------------------------------------------------------------------------------------------|-----------------------------------------------------------|
|  <p>14201</p> | <p>STRAIGHT THREAD IN/OUT ADAPTER KIT 1" x 1"</p> |  <p>1483A</p> | <p>PVC IN/OUT ADAPTER KIT 1" GLUE</p> |
|  <p>1454A</p> | <p>BRASS IN/OUT ADAPTER KIT - ¾" - 1" SWEAT</p> |  <p>7842A</p> | <p>BRASS IN/OUT ADAPTER KIT - 1" - 1 ¼" SWEAT</p> |

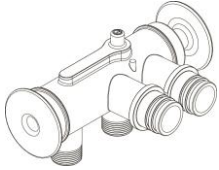
System By-pass

| Part and Part No. | Description | Part and Part No. | Description |
|----------------------------------------------------------------------------------------------------------|--------------------------------------------------------------------------------------------------------------------------------------------------------|----------------------------------------------------------------------------------------------------------|---------------------------------------------------------------------------------------------------------------------------------------------------------------|
|  <p>14508A</p> | <p>BLENDING BY-PASS VALVE ¾" STRAIGHT THREAD (straight thread, can be used with hose connection, do not use with NPT fittings)</p> |  <p>14894</p> | <p>LONG BLENDING BY-PASS VALVE - ¾" STRAIGHT THREAD (straight thread, can be used with hose connection, do not use with NPT fittings)</p> |

Troubleshooting

- | | |
|----------------------------------------------------------------------------------------------------------------------------------------------------------------------------------------------------------------------------------------------------------------------------|---------------------------------------------------------------------------------------------------------------------------------------------------------------------------------------------------------------------------------------------------------------------------------------------------------------------------------------------------------------------------------------------------------------------------------------------------------------------------------------------------------------------------------------------------|
| 1. Gather information. | <p>Ask questions, find out what is the problem. What is the customer's complaint? This may identify simple corrections external to the equipment.</p> <ul style="list-style-type: none"> • Has there been any recent plumbing work done? • Has the water been shut off for any reason? • Have fire hydrants been flushed recently in the area? • Have they used more water than normal recently? • Has the brine drum recently run out of salt? • How much salt have they been using? |
| 2. Test the water. | <p>Test both the raw water before the softener and the cold water at closest tap after the softener. The by-pass position or other plumbing connections may affect cold water test results.</p> <ul style="list-style-type: none"> • Essential systems will allow a small amount of hard water to service during each regeneration. This function may result in hardness blending in the hot water. • Raw water is used to check if the AccuDial settings. |
| 3. Observe the installation. | <p>Check status of by-pass valve (open/closed), brine drum (full, empty, bridged), prefilter (plugged), correct AccuDial setting, inlet/outlet lines correct, kinks or restrictions in drain line or drain line elevated over 2.4m (8 ft) or more than 4.6m (15 feet) horizontally?</p> |
| 4. Run soft water to service. <div style="margin-left: 40px;">Metering Rate:</div> <div style="margin-left: 40px;">Essential 8 ≈ 19.7L (5.2 gal) per tooth</div> <div style="margin-left: 40px;">Essential 11, 17 ≈ 37.8L (10 gal) per tooth</div> | <p>Verify metering.</p> <ul style="list-style-type: none"> • Watch the AccuDial. Is it advancing clockwise? • Watch the no back pawl as the AccuDial advances clockwise. Does the no back pawl drop into the next tooth? • Measure the metering rate. Measure the rate by running water at a controlled rate 3.8 lpm (1 gal a minute) and time how long it takes the no back pawl to drop into the next tooth. |
| 5. Place unit in brine position. | <p>Verify vacuum at brine elbow.</p> <ul style="list-style-type: none"> • Remove the brine line from the brine elbow and verify if there is suction. • Is the suction smooth without interruption? • Is there any water coming from the brine elbow? |
| 6. Remove the brine valve. | <p>Verify correct brine setting instructions.</p> <ul style="list-style-type: none"> • Is preset at a float cup height. • Is adjuster tube cut down to the correct tab? • Is the float cup set at the correct measurement? |

7. Look for low flow in the distribution system.

Leaky toilets, faucets, etc. This may allow water to pass by unmetered, causing hard water.

Low flow means less than 2.8 lpm (0.75 gpm) in Essential systems. A leaky faucet or running toilet will typically be less than these flow rates. If it is less than these flow rates, the water will not turn the turbine, so the meter gears will not turn, and the system may not regenerate when it should.

8. Measure water pressure.

Check at brine elbow while one faucet is wide open and valve is in backwash position.

Place the valve in the brine draw position, allowing the draw port to depressurize. Remove the brine elbow and thread on a ¼" threaded coupling with a pressure gauge on the other end. Place the valve in the backwash position, open one faucet, and note the pressure reading – it must be at least 1 – 1.7 bar (15-25 psi).

9. Measure backwash flow rate.

Using a container with a known volume check the drain flow with the unit in backwash and a faucet running, timing how long it takes to fill the container.

Essential 8 and 11 backwash rate ≈ 3.8 lpm (1.0 gpm)

Essential 17 backwash rate ≈ 7.6 lpm (2.0 gpm)

(Compare these results to specified backwash flow for model.)

10. Place unit at the end of backwash and allow it to shut off on its own.

This may take several minutes.

A slight drip to the drain is allowable. If the drip will fill the test tube from your hardness test kit (10 ml) in less than 45 seconds, it may cause a hard water situation.

If the water is soft, follow the trouble shooting steps for running to drain. If the water at the drain is hard and the unit is producing soft water, check the drain valve seats in level 5 for foreign material.

Softener Troubleshooting

Hard Water

| Problem | Possible Cause | Solution |
|--------------------------------------------|-----------------------------------------------------------------------------------------------------------------------------------------------------------------------------------------------------------------------------------------------------------------------------------------|--------------------------------------------------------------------------------------------------------------------------------------------------------------------------------------------------------------------------------------------------------------------------------------|
| 1. Water meter disc not turning. | <ul style="list-style-type: none"> A. Bad meter drive pawl B. Meter drive spring not seated properly C. No back pawl missing or broken D. Damaged tooth on meter disc E. Damaged gear in gear stack | <ul style="list-style-type: none"> A. Replace meter drive pawl B. Reinstall meter drive spring C. Install new no back pawl D. Replace meter disc E. Re-gear Level 1 |
| 2. Unit will not regenerate automatically. | <ul style="list-style-type: none"> A. Meter disc not turning B. Control disc will not advance out of service position C. Damaged teeth on control disc D. Control valve will not open E. Drain line/backwash flow control restricted | <ul style="list-style-type: none"> A. See # 1 above B. Replace regeneration start pawl C. Replace control disc D. Check for debris - clean if present. E. Remove restriction/change backwash flow control of necessary |
| 3. No vacuum in brine position. | <ul style="list-style-type: none"> A. Plugged venturi B. Plugged backwash flow control/drain line C. Damaged outlet main valve seat seal | <ul style="list-style-type: none"> A. Clean flow control, venturi throat and Nozzle, note do not use paper clip B. Clean/replace flow control/free obstruction from drain line C. Replace main valve seat seal |
| 4. Over/under dosing of salt. | <ul style="list-style-type: none"> A. Brine drum/valve not level B. Bridged salt in drum C. Brine valve is not set correctly D. Brine valve is faulty E. Brine valve is dirty F. Venturi nozzle is plugged | <ul style="list-style-type: none"> A. Level the brine drum/valve B. Break up the solidified salt C. Set the brine valve correctly D. Replace the brine valve E. Clean the brine valve F. Clean venturi throat and nozzle |
| 5. The by-pass is open or leaking. | <ul style="list-style-type: none"> A. Accidentally left in "Open" position B. Damaged seal in by-pass valve or bad ball valve in a three way by-pass configuration C. Bleeder valve open on by-pass | <ul style="list-style-type: none"> A. Close the by-pass valve B. Repair/replace bad valve(s) C. Close bleeder valve |

Frequent Regeneration

| Problem | Possible Cause | Solution |
|-----------------------------------------------------|--------------------------------------------------------------------------------------------------------------------------------------------------------------------------------------------------------------------------------------------------------------------------------------------------------------------------------|--------------------------------------------------------------------------------------------------------------------------------------------------------------------------------------------------------------------------------------------------------------------------------------------------|
| 1. High water usage. | <ul style="list-style-type: none"> A. Customer uses more water than expected B. Leak in plumbing or fixture (greater than minimum flow rate required for metering) | <ul style="list-style-type: none"> A. Inform customer of expected frequency based on actual usage B. Repair the leak |
| 2. Unit regenerates more frequently than necessary. | <ul style="list-style-type: none"> A. Incorrect AccuDial setting B. Meter disc not moving and regeneration start pawl in gap C. Control valve stuck in "Open" position (causes continuous regeneration) due to debris under seal or stray pressure signal D. Incorrect meter gearing | <ul style="list-style-type: none"> A. Adjust AccuDial B. Refer to "Hard Water Troubleshooting" section step 1 C. Remove debris (if present) or replace level 1 (stray pressure signal due to poor seal under ceramic disc) D. Rework the meter gearing |
| 3. Lack of understanding regarding Kinetico units. | Customer is used to electrical units with timers | Explain to customer that Kinetico units regenerate based on volume as opposed to time |

Unit Stuck in Cycle

| Problem | Possible Cause | Solution |
|-----------------------------------------------|---------------------------------------------------------------------------------------------------------------------------------------------------------------------------------------------------------------------------------------------------------------------------------------------------------------------------------------------|-----------------------------------------------------------------------------------------------------------------------------------------------------------------------------------------------------------------------------------------------------------------------|
| 1. Unit stuck in regeneration/backwash cycle. | <ul style="list-style-type: none"> A. Control flow path is plugged at the regeneration nozzle or regeneration flow control B. Regeneration drive pawl and/or spring is weak or broken C. Damaged tooth on control disc D. Eccentric pin is worn/damaged E. Regeneration gears not moving | <ul style="list-style-type: none"> A. Clean the regeneration flow path B. Replace regeneration drive pawl C. Replace control disc D. Replace eccentric pin (snap fit) E. Free obstruction or impediment to gearing |
| 2. Unit stuck in service cycle. | <ul style="list-style-type: none"> A. Regeneration start pawl broken or missing B. Unit will not regenerate automatically | <ul style="list-style-type: none"> A. Replace or install regeneration start pawl B. Refer to "Hard Water Troubleshooting" section step 2 |

Salty Water

| Problem | Possible Cause | Solution |
|-----------------------------------------------------------|-------------------------------------------------------------------------------------------------------------------------------------------------------|-----------------------------------------------------------------------------------------------------------------------------------------------------------------------------------------------------------------------|
| 1. Overdosing of salt. | A. Brine valve set incorrectly B. Brine valve not seating properly C. Rubber band not removed D. Leak in brine valve | A. Set the brine valve correctly B. Replace brine valve C. Remove rubber band from float cup D. Repair leak/replace brine valve |
| 2. Restricted drain flow. | A. Drain line kinked or clogged B. Backwash flow control restricted C. Long drain tubing run D. Drain tubing rises higher than 2.4m (8 feet) | A. Clear obstructions; ensure drain flows smoothly and clearly B. Clean/replace backwash flow control C. Shorten length of tubing or increase size of drain tubing D. Reduce rise to less than 2.4m (8 feet) |
| 3. Low water pressure. | A. Plugged prefilter B. Pressure setting too low C. Fouled/damaged resin bed | A. Change prefilter B. Increase feed pressure C. Replace resin |
| 4. Upper distributors partially blinded (downflow units). | Foreign material or fines lodged into the slots | Clean or replace upper distributors |

High Salt Use

| Problem | Possible Cause | Solution |
|------------------------------------|-------------------------------------|-------------------------------------|
| 1. Unit regenerates too frequently | See "Frequent Regeneration" section | See "Frequent Regeneration" section |
| 2. Overdosing of salt | See "Salty Water" section | See "Salty Water" section |

Equipment Noise

| Problem | Possible Cause | Solution |
|------------------------------------------------------------------------------------------------------------------|----------------------------------------------------------------------------------------------------------------------------------|-----------------------------------------------------------------------------------------------------------------------|
| 1. Unit makes squealing noise during regeneration | Control disc not flat or sealing properly against the ceramic disc | Replace control disc, balance piston spring and balance piston O-ring |
| 2. Unit makes gurgling, hissing, or bubbling sound (A small amount of Noise during startup and refill is normal) | A. Trapped air in piping following installation B. Air being drawn into piping C. Brine line and/or valve not air checking | A. Release all trapped air from piping B. Identify source and fix air leak C. Identify and replace faulty parts |
| 3. Groaning while water being used | High feed pressure | Reduce feed pressure |

Run to Drain

| Problem | Possible Cause | Solution |
|-----------------------------------------------------------------------------------|--------------------------------------------------------------------------------------------------------------------------------------------------------------------------------------------------------------------------------------------------------|---------------------------------------------------------------------------------------------------------------------------------------------------------------------------------------------------------------------------------------------------------------------------------------------|
| 1. Balance Piston O- ring not seated properly. | A. O-ring off-center B. O-ring pinched or damaged | A. Depress actuator several times to try to seat the O-ring B. Replace O-ring |
| 2. Bad control disc. | Map side of control disc scored | Replace control disc |
| 3. Drain or control valves not seated properly. | A. Debris trapped under the seals B. Low water pressure (this may prevent proper seating of seals) | A. Remove debris B. Increase water pressure |
| 4. Low Water Pressure (see also “Sticking in Cycle”). | Pressure at the brine fitting lower than 1 bar (15 psi) will affect the hydraulic movements within the softener or filter valves and may not allow drain or control valves to close. | Increase feed water pressure. Check pressure before softener and after softener. If there is a severe pressure loss above 1 bar (15 psi) across the system they may have some blockage in the resin tanks. If filter and softener, or two filters are installed in series, use lockout kit. |
| 5. The main valve piston quad rings or level four internal quads are not sealing. | A. Main valve quad rings may be rolled, twisted, or damaged B. Water may be leaking from the main valve seat side of the level 4 to a non pressurized area on the piston side of the level 4. C. Seals may be damaged by chlorine or chloramines | A. Replace main valve piston quad rings B. Replace small retainer quad rings in level 4 or replace level 4 (the piston shafts seal against these quad rings, and they cannot be seen without removing the pistons). C. Replace with blue seals for use with chloramines |
| 6. Plugged signal hole or broken non-serviceable glue seal under ceramic disc. | Age and wear, or contamination from poorly filtered feed water | Clean signal holes with paper clip or compressed air; replace Level 1, if necessary. |

Parts

| Complete Modules | |
|------------------|-----------------------------|
| #16100 | - Module MN BS Essential 8 |
| #15860 | - Module MN BS Essential 11 |
| #15858 | - Module MN BS Essential 17 |

| Level 1 Assembly Parts | |
|------------------------|--------------------------------------------------------|
| 1 | #15030 - Solitaire Cap Assembly |
| 2 | #1460 - Actuator O-ring - 010 |
| 3 | #14706A - AccuDial Return Spring |
| 4 | #14707A - Solitaire Demand Override Actuator |
| 5 | #14927 - Balance Piston w/Guide |
| 6 | #1070A --Balance-Piston O-ring |
| 7 | #5448 - Balance-Piston-Spring |
| 8 | #14708 - Upper Meter Disc |
| 9 | #16023A - Lower Meter Disc A - J - Essential 8, 11, 17 |
| 10 | #14712C - Solitaire Control Disc |
| 11 | #14755A - Solitaire Level One w/Cer & Stem Gear Asy. |

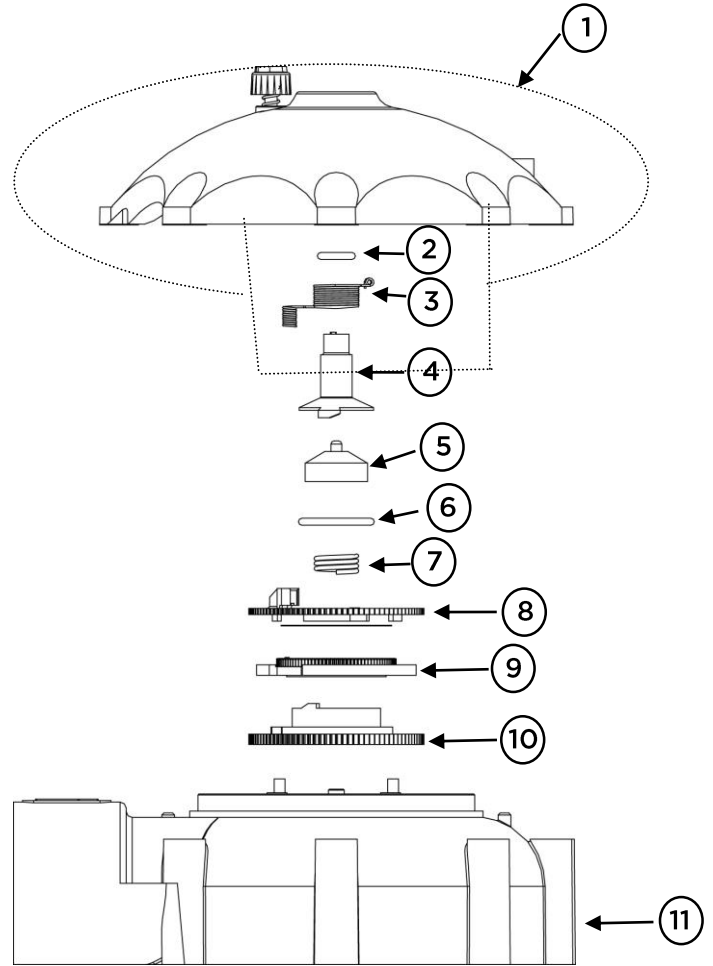

| Level 1 Metering Pawls Parts | |
|------------------------------|-------------------------------------------|
| 1 | #5511 - Regeneration Drive Pawl Assembly |
| 2 | #14716 - Solitaire Eccentric Pin |
| 3 | #2657 - Stem Gear O-ring |
| 4 | #14717 - Solitaire Support Pin |
| 5 | #14719A - Meter Drive Pawl - AccuDial |
| 6 | #14715A - No-Back Pawl - AccuDial |
| 7 | #7010A - Meter Drive Pawl Spring |
| 8 | #15031 - Pawl Asy, Regen Start - AccuDial |

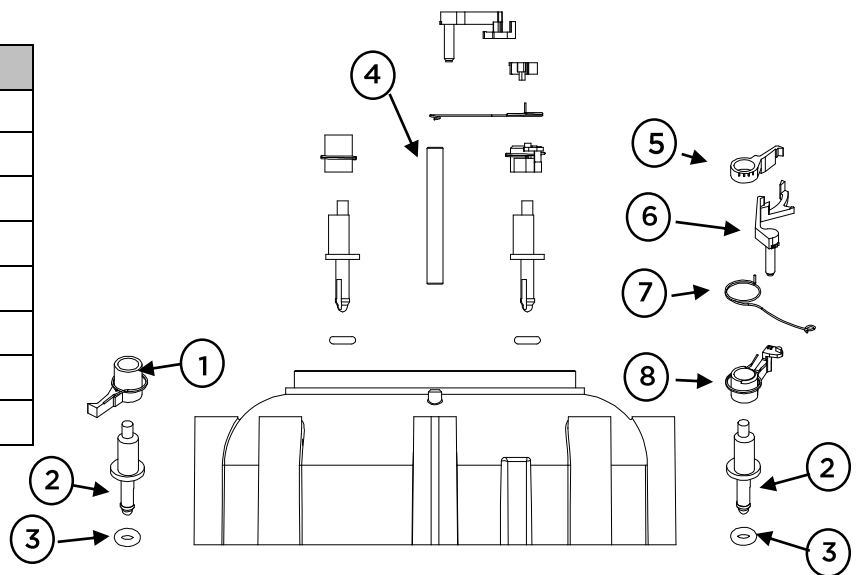

| Level 1 Gearing Parts | | |
|-----------------------|--------------------------------------|--------------------|
| 1 | #14812A - Two-Stack Turbine Retainer | |
| 2 | #11015A - Turbine, Regen 8 Gear | |
| 3 | #1022 - E-ring | |
| 4 | #1773 - Level One Gear Washer | |
| 5 | #1525 - Gear #4 | |
| 6 | #1524 - Gear #3 | |
| 7 | #1521 - Level One Stem Gear | |
| 8 | #7859 -Meter Turbine Retainer | |
| 9 | #14724 -Meter Turbine | |
| | Essential 11 | Essential 8 and 17 |
| 10 | #2431- Gear #11 | #2432- Gear #12 |
| 11 | #2432 -Gear #12 | #2433 -Gear #13 |
| 12 | #2433 -Gear #13 | #2434 -Gear #14 |
| 13 | #2440B -Gear #20 | #2440B -Gear #20 |

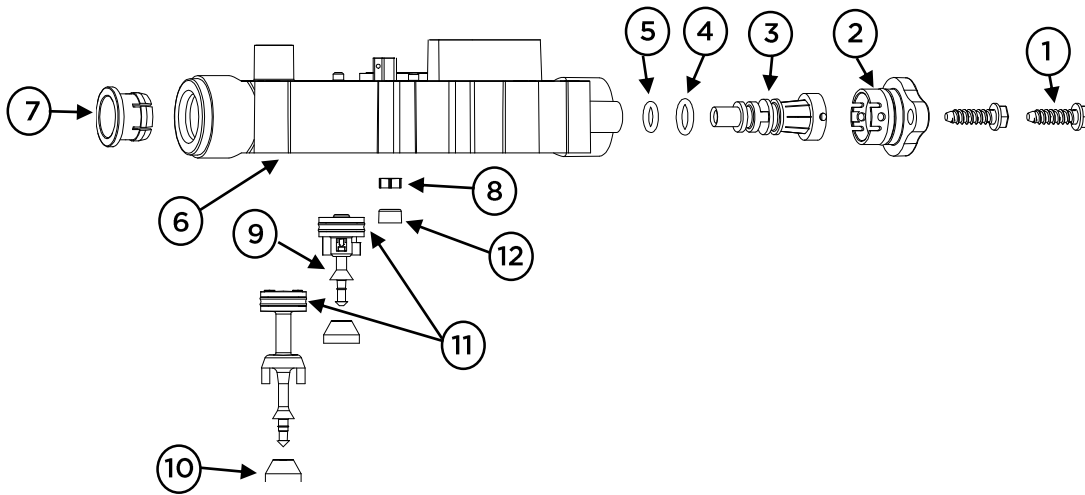
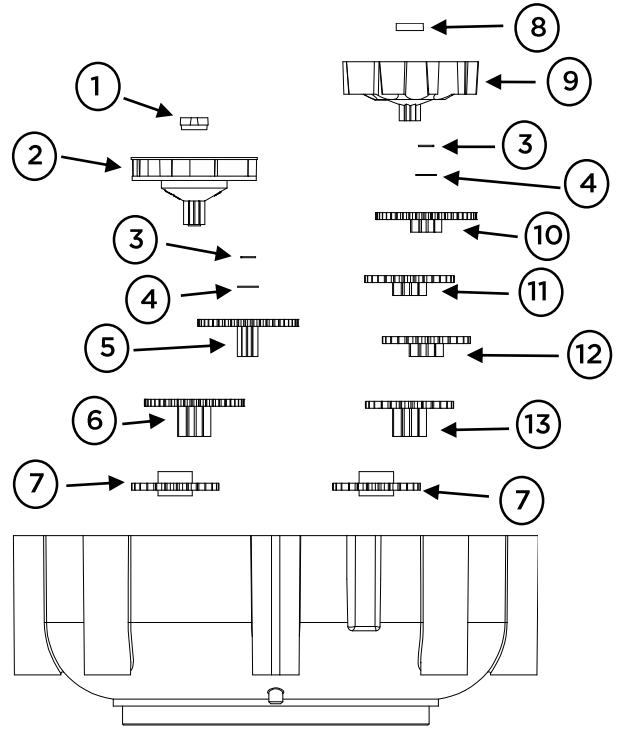

| Level 3 Assembly Parts | | | |
|------------------------|------------------------------------------|----|-----------------------------------------------|
| 1 | #1010 - SS Cap Screw | 7 | #14728 - Insert Collet - 0.50 |
| 2 | #14807 - Venturi Access Plug w/O-ring | 8 | #9183B - Flow Control - 0.20 - Blue |
| 3 | #14809 - Solitaire Venturi - Tan | 9 | #13720A - Spring-Loaded Control Valve, w/Quad |
| 4 | #10634 - O-ring -011 | 10 | #7869 -Control/Drain Valve Seal |
| 5 | #1460 - Actuator O-ring -010 | 11 | # 1590 - Quad Ring Drain Control |
| 6 | #14791B - Solitaire Level Three - Welded | 12 | # 15821A - Solitaire L3, Filter Disc |

| Level 4 Parts | |
|---------------|----------------------------------------------------------------------------------------------------------------------------------------|
| 1 | #14808 - Solitaire By-pass Seat, w/Seal |
| 2 | #14806 - Unitary Inlet Valve, w/Quad |
| 3 | #13695 - Piston, L-4 |
| 4 | Essential 8 and 11 #4409 - Backwash Flow Control - 1.0 GPM Essential 17 #1054 - Backwash Flow Control - 2.0 GPM |
| 5 | #14792A - Solitaire Level Four - Welded |
| 6 | #13696 - Level Four Seat, w/Seal |
| 7 | #14725 - Seal Only, Seat |
| 8 | #1550 - Quad Ring, 125 Piston |
| 9 | #1590 - Quad Ring, 110 (Internal Not Shown) |
| 10 | #7865 - Seal, Main Seat |

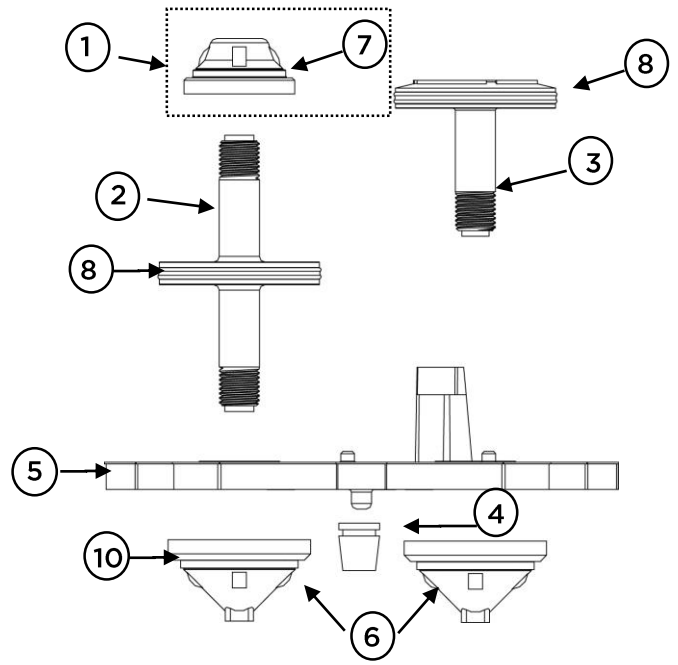

| Level 5 Assembly Parts | |
|------------------------|------------------------------------------|
| 1 | #14793C - Solitaire Level Five - Welded |
| 2 | #12856B - Insert Collet - 3/8 with M. G. |

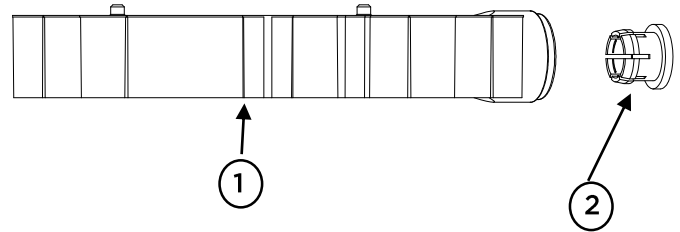

| Level 6 Assembly Parts | |
|------------------------|------------------------------------------------------------------|
| 1 | #15647B - Solitaire Level Six - Welded/Drilled with Counter Sink |
| 2 | #15782 - Upper Distributor with Clip Holes |
| 3 | #15607 - Pressed Solitaire L-6 Screen |
| 4 | #10279 - Upper Distributor Clip |
| 5 | #15817 - Solitaire Check Stem |

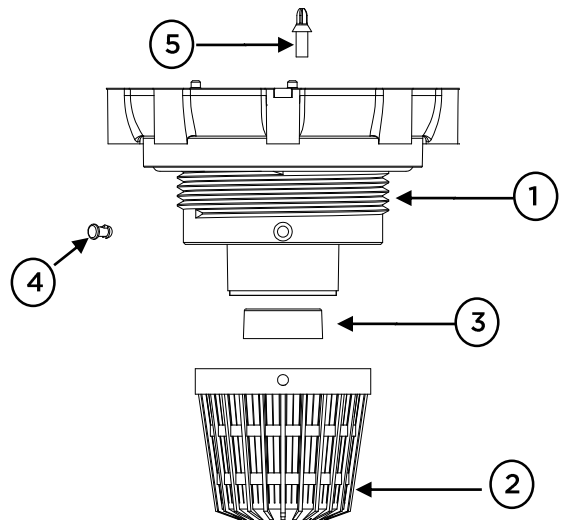

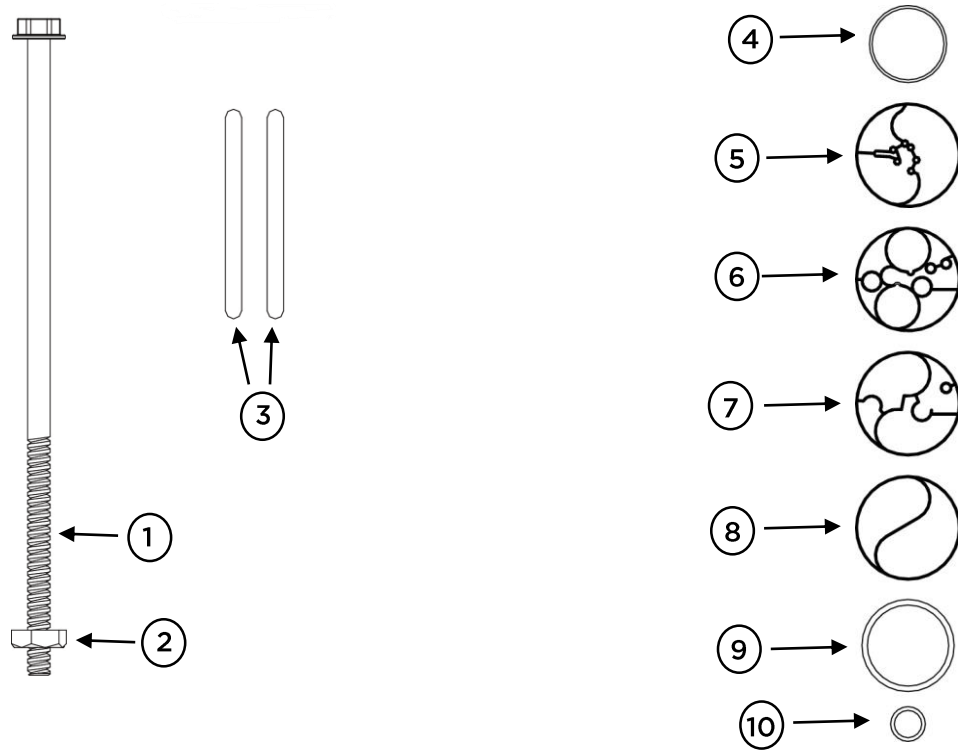

| Levels and Level Seals | |
|------------------------|-------------------------------------------|
| 1 | #14703A -Solitaire Main Valve Screw |
| 2 | #14741 - Solitaire Main Valve Nut |
| 3 | #1328 - In/Out Tank Adapter O-ring, 122 |
| 4 | #14745 - O-ring - 148 Cap Seal |
| 5 | #14727 - Solitaire Level Three Seal |
| 6 | #14733 - Solitaire Level Four Seal |
| 7 | #14736 - Solitaire Level Five Seal |
| 8 | #14739 - Solitaire Level Six Seal |
| 9 | #14742 - O-ring, 338 Tank / L6 |
| 10 | #1800 - Distributor Tube O-ring, 215 - L6 |

| Resin | | |
|--------|---------------|--------------|
| #13370 | Fine Mesh | Essential 8 |
| #13370 | Fine Mesh | Essential 11 |
| #15899 | Standard Mesh | Essential 17 |

Brines Tanks and Tanks

203mm x 330mm (8" x 13") Essential 8 Media Tank - **Part No. 15941**

203mm x 432mm (8" x 17") Essential 11 Media Tank - **Part No. 15801**

203mm x 610mm (8" x 24") Essential 17 Media Tank - **Part No. 15964**

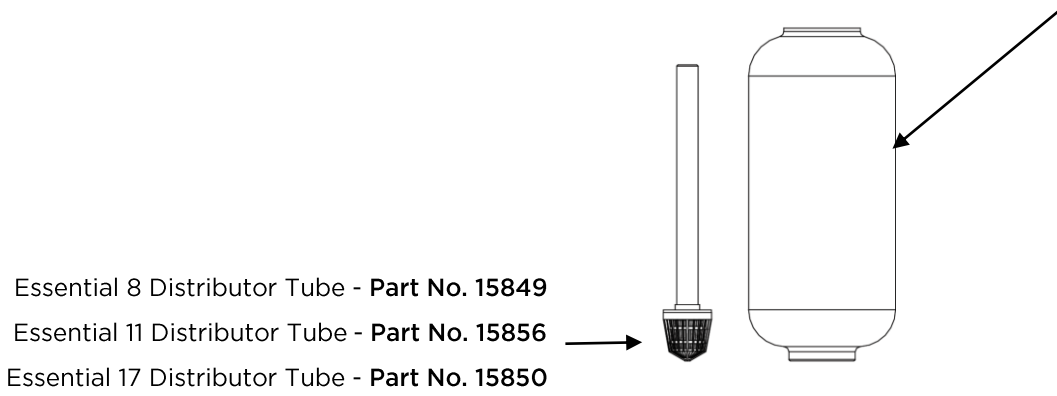

Essential 8 Cabinet Assembly - **Part No. 15939**

Essential 11 Cabinet Assembly - **Part No. 15962**

Essential 17 Cabinet Assembly - **Part No. 15963**

Essential 8 Brine Valve Assembly - **Part No. 15936**

Essential 11 Brine Valve Assembly - **Part No. 15804**

Essential 17 Brine Valve Assembly - **Part No. 15840**

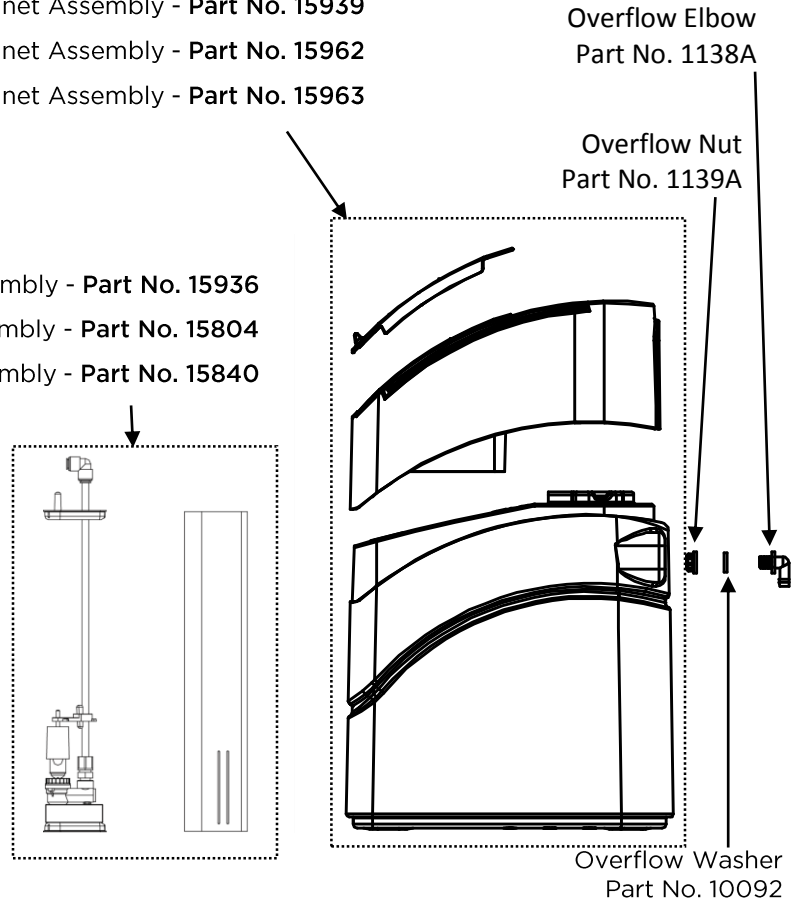

essential

SERIES



www.kinetico.eu