

CATALOGUE
2022

Bandini
WATER HEATERS

Bandini

WATER HEATERS

MANUFACTURERS OF
ELECTRIC WATER HEATERS
SINCE 1955

INDEX

THE COMPANY	4
CERTIFICATES	6
LIST OF PROJECTS	09
ELECTRIC WATER HEATERS	12
WOOD BOILERS	44
THERMO COMBINED WATER HEATERS	48
BUFFER TANKS	58
PACKAGING DIMENSIONS	66

BANDINI

A story of family, hard work, innovation

It was the year 1955 when a young Franco Bandini, with an entrepreneurial vision, started his own activity in the manufacturing of electric water heaters. Italy was facing the delicate and crucial phase of the post-war reconstruction: the burgeoning enthusiasm was leading to new economical opportunities.

At the beginning the activity was nothing more than a craft shop, with a daily turnover of 10 units produced per day.

Bandini Water Heaters SPA kept on its track of growth during the years, where Franco's son, Sergio, took the leading role of the activity.

Recently the third generation of Bandini family, Samuele, joined the family business taking care of the Marketing and Export.



BANDINI TODAY

Bandini Water Heaters SPA today is the perfect synthesis between its 68 years of history and the continuous research of new paths & experiences. The attention to the customer's needs, the flexibility, efficiency, are the key values.



300.000 units produced as yearly turnover - 50 employees



50% share of the production -> national market - 50% share of the production -> export market



3 industrial plants where we cover the 100% of the productive cycle



EXPERIENCE, RESEARCH AND TECHNOLOGY

From Choice of materials, to the use of new technologies, BANDINI always grant to end users a range of products of quality.

- **EN60335-1:2002** Safety of domestic appliances and similars.
Part 1: general conditions
- **EN60335-2-21:2003** Safety of domestic appliances and similars. Part 2: specific directives for storage water heaters
- **DIR 2004/108/EMC**
- **DIR 2011/65/ROHS ROHS**
- **DIR 2013/812/UE Ecolabel**
- **DIR 2013/814/UE Ecodesign**
- **PrEN50440:2013** Energy Efficiency for storage water heaters (domestic use)
- **DIN 4753-3** Protection against corrosion with glass enamelling treatment
- **EN 60379:2004** Method of measures for the performances of domestic storage water heaters
- **EN10130 EN10111** STEEL
- **EN12438:2015-DIN4753,T6-ISO 26202:07** MAGNESIUM ANODE
- **EN 60335-1; EN60335-2-21** HEATING ELEMENT
- **EN60730-1; EN60730-2-9** THERMOSTAT



Company certified with Quality
Management System in accordance to UNI
EN ISO 9001

THE RIGHT CHOICE FOR YOUR COMFORT

Our water heaters are manufactured in various capacities & dimensions in order to meet all the end user's needs.



TANK:

made from high quality steel, the 100% of tanks undergoes double pressure test after welding phase.

OUTLET PIPE:

in stainless steel.

EXTERNAL PROTECTION:

painted with epoxidic powders.

INTERNAL PROTECTION:

internal tank glass enameled.

ENAMELLING PROCESS:

continuosly monitored as per DIN4753 normative.

THERMAL INSULATION:

polyhurethane foam.

CATHODIC PROTECTION:

magnesium anode, giving longer life to the product.

THERMOSTAT:

regulation of temperature and cut-off of the functioning, in case of anomaly.

HEATING ELEMENT:

in copper

BANDINI the company

BANDINI distributes its
products in all the major
markets around the world



PROJECT:

Bandini around the world

Following a list of major projects where we supplied our product

2008

DUBAI

Project:

ROSE ROTANA SUITES

Product supplied:

ELECTRIC WATER HEATERS
80/100 LTS HORIZONTAL

2009

BAHRAIN

Project:

VILLAMAR – BAHRAIN

Product supplied:

ELECTRIC WATER HEATERS
VERTICAL 50/100 LTS HORIZONTAL
WALL mounted

2010

LIBYA

Project:

WEST BENGHAZI NEW TOWN 20000
HOUSING

Product supplied:

ELECTRIC WATER HEATERS
VERTICAL 50/80/100 LTS HORIZONTAL
100LTS

Quantity involved:

70.000 units

2010

UNITED NATIONS

Project:

UNITED NATIONS PEACEKEEPING
FORCE

IN CYPRUS (UNFICYP)

Product supplied:

ELECTRIC WATER HEATERS
VERTICAL 50/80/100 LTS

2010

LEBANON

Project:

UNIFIL Naqoura Camp – LEBANON

Product supplied:

ELECTRIC WATER HEATERS
VERTICAL 50/80/100 LTS

2010

KINGDOM OF BAHRAIN

Project:

10 VILLA AT SAAR PROJECT

Product supplied:

ELECTRIC WATER HEATERS
VERTICAL 50/80/100 LTS HORIZONTAL
100LTS

2014

DUBAI

Project:

DAMA Golf (3 Cluster) Course
Development

Client: M/s. AKOYA BY DUBAI LAND.

Consultant: M/s. NAGA Architects,
Designers & Planners.

Product supplied:

ELECTRIC WATER HEATERS 80/100
LTS HORIZONTAL

2014

ABU DHABI

Project:

MARINA BLOOM DEVELOPMENT

Product supplied:

ELECTRIC WATER HEATERS
80/100 LTS HORIZONTAL
ABR AL MUTAWASIT LLC 100LTS

2021

CONGO

Project:

TWIN TOWERS KINSHASA

Client: ADVANCED MECHANICAL
SOLUTIONS

Product supplied:

ELECTRIC WATER HEATERS
100-150-200LT VERTICAL



2016

SHARJAH

Project:

AL ZAHIA DEVELOPMENT – GARDEN APARTMENT.

2006

DUBAI

Project:

BURJ DUBAI DEVELOPMENT BURJ VIEWS

2016

DUBAI

Project:

B+G+12 FLOORS+GYM+ROOF (RESIDENTIAL BLDG.)

2021

SHARJAH

Project:

BABEL TOWER 2 RESIDENTIAL BUILDING

2006

DUBAI

Project:

TIME PLACE (3B+G+34) FLOOR RESIDENTIAL BLDG.

2016

DUBAI

Project:

DAMAC G+7 AKOYA PARK BUILDING

2003

DUBAI

Project:

UP TOWN MIRDIF DEVELOPMENT PACKAGE C. GARDEN APARTMENTS

2008

DUBAI

Project:

MARINA WEST-RESIDENTIAL DEVELOPMENT

2017

DUBAI

Project:

G+4P+13F+R (RESIDENTIAL BLDG.)

2004

DUBAI

Project:

AL FARDAN TOWERS

2009

DUBAI

Project:

THE BAY CENTRAL , 2 TOWERS

2018

DUBAI

Project:

THE PALM TOWER

2005

DUBAI

Project:

3B+G+30 BLDG (RESIDENTIAL BLDG.)

2012

DUBAI

Project:

PALMA RESIDENCE VILLAS

2019

DUBAI

Project:

VIDA HOTELS & RESIDENCES

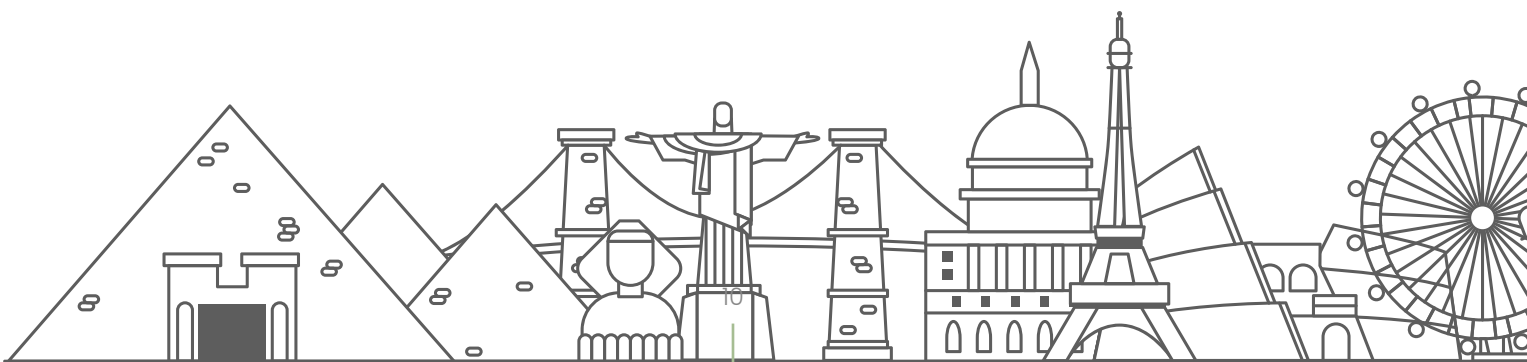

2005

DUBAI

Project:

2B+G+14+R (RESIDENTIAL BLDG.)

2014

DUBAI

Project:

DAMAC AKOYA G+7 APARTMENTS

2016

ABUDHABI

Project:

ANSAM DEVELOPMENT PHASE 1

2006

DUBAI

Project:

BURJ DUBAI DEVELOPMENT THE OLD TOWN

2015

DUBAI

Project:

AL ALI DEVELOPMENT COMMERCIAL AND RESIDENTIAL BUILDING

2016

ABUDHABI

Project:

CITY OF LIGHTS

2008

BAHRAIN

Project:

VILLAMAR AT THE HARBOUR

2008

BAHRAIN

Project:

VILLAMAR AT THE HARBOUR

2017

ABUDHABI

Project:

HYDRA AVENUE PHASE 2 - C7, C8 & C9

2018

ABUDHABI

Project:

WATER'S EDGE RESIDENTIAL DEVELOPMENT

2022

TURKEY

Project:

DENIZBANK - A12 ST - 400 BANK BRANCHES IN TURKEY

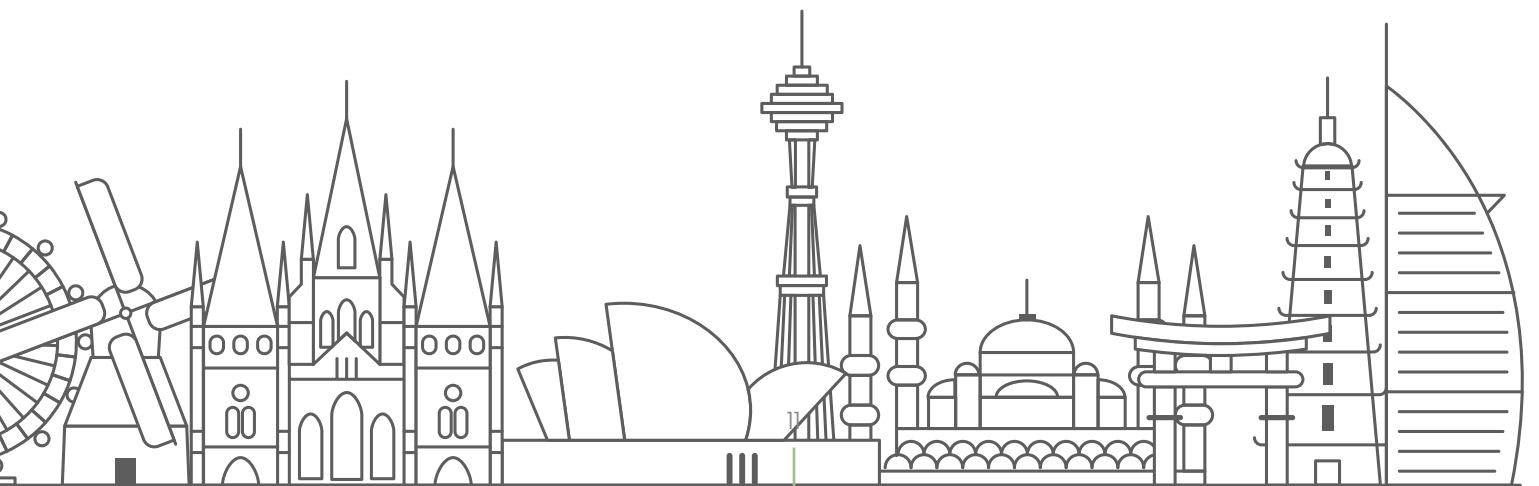



01. **ELECTRIC** **WATER HEATERS**



A5

A5 SP / A5 ST

Electric storage water heater, small capacity Available both over-sink and under-sink version. Available also with external regulation of temperature.



+ Why to choose it:

- Perfect to heat water for kitchen or sink use
- High versatility of installation, even into not-on-sight furniture
- Small dimensions require short period to heat water

TECHNICAL DATA

	A5 SP	A5 ST
Thermal Dispersiom 50° (KWh/24h)	0,323	0,323
Power (W)	1500	1500
Voltage (V)	230	230
Heating time (Δt 50°)	16'	16'
Max working temperature (C°)	65°	65°
Max working pressure (bar)	8	8
Protection against humidity	IPX4	IPX4
Insulation class	I	I
Profile	XXS	XXS
Energy Class	B	B

+ **INCREASED MAGNESIUM ANODE,**
FOR TOTAL PROTECTION AGAINST
VACANT CURRENTS

+ **GLASS ENAMELED**
TANK

+ **ABSENCE OF CFC;**
POLYURETHANE FOAM
FOR ECOLOGICAL THERMAL
INSULATION

+ **EXTERNAL REGULATION**
OF TEMPERATURE



**COPPER
HEATING ELEMENT**

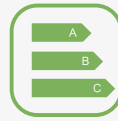

**ERP
2017**



**INSTALLATION
KIT**



**EXTERNAL REGULATION
OF TEMPERATURE**



**LED
CONTROL**



**ROHS
COMPONENT**



**POLYURETHANE
FOAM CFC FREE**



THERMOSTAT



**MAGNESIUM
ANODE**

DIMENSIONS

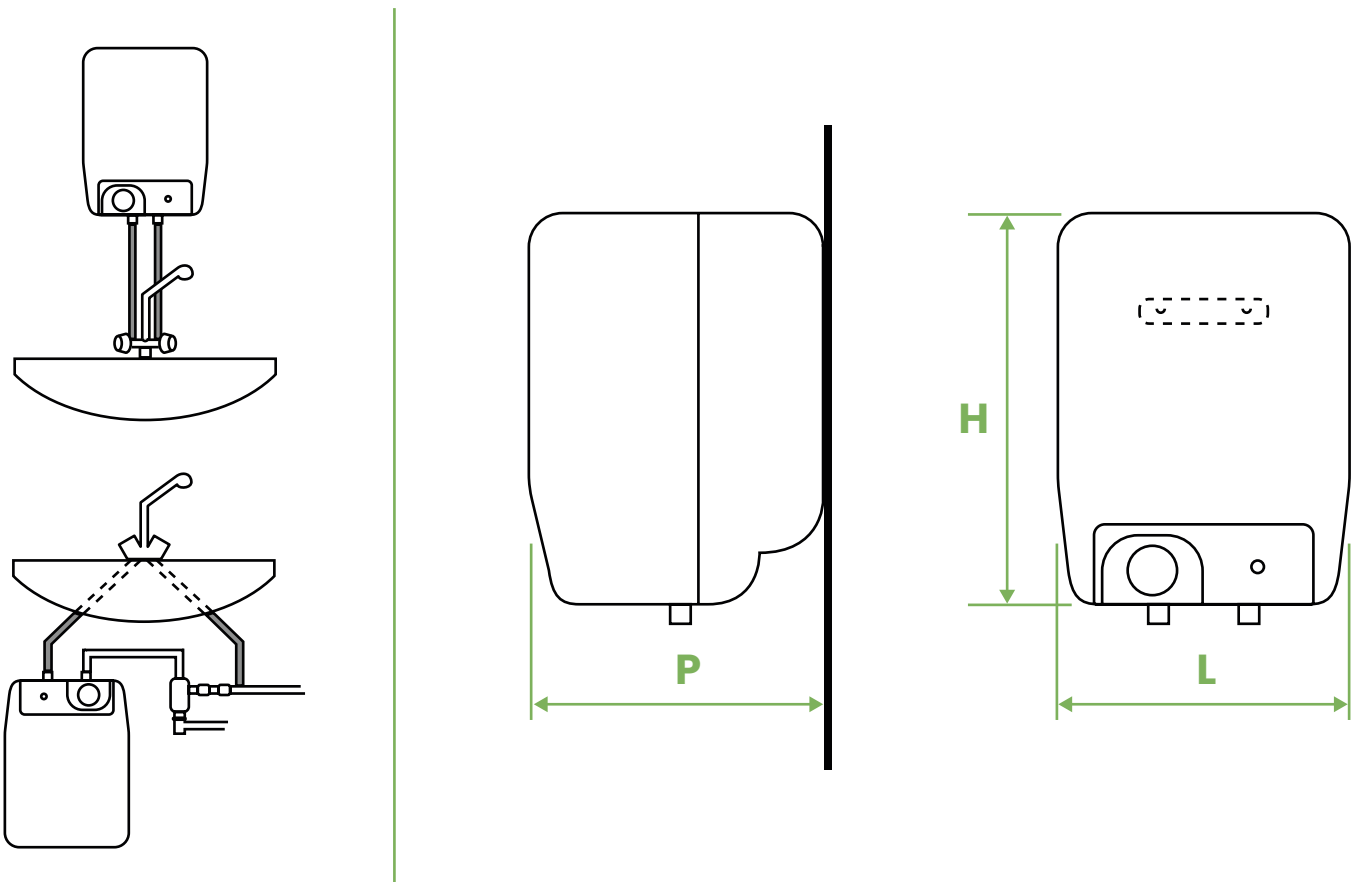

	H	L	P
A5 SP over-sink	340 mm	250 mm	245 mm
A5 ST under-sink	340 mm	250 mm	245 mm

A12



A12 SP / A12 ST

Electric storage water heater, small capacity Available both over-sink and under-sink version.

+ Why to choose it:

- Perfect to heat water for kitchen or sink use
- High versatility of installation, even into not-on-sight furniture
- Small dimensions require short period to heat water

TECHNICAL DATA

	A12 SP	A12 ST
Thermal Dispersiom 50° (KWh/24h)	0.38	0.38
Power (W)	1500	1500
Voltage (V)	230	230
Heating time (Δt 50°)	28'	28'
Max working temperature (C°)	60°	60°
Max working pressure (bar)	8	8
Protection against humidity	IPX4	IPX4
Insulation class	I	I
Profile	XXS	XXS
Energy Class	B	C

+ **INCREASED MAGNESIUM ANODE,**
FOR TOTAL PROTECTION AGAINST
VACANT CURRENTS

+ **GLASS ENAMELED**
TANK

+ **ABSENCE OF CFC;**
POLYURETHANE FOAM
FOR ECOLOGICAL THERMAL
INSULATION

+ HUMIDITY PROTECTION CLASS
IPX4



**COPPER
HEATING ELEMENT**

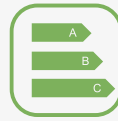

**ERP
2017**



**INSTALLATION
KIT**



**MAGNESIUM
ANODE**



**LED
CONTROL**



**ROHS
COMPONENT**



**POLYURETHANE
FOAM CFC FREE**



THERMOSTAT

DIMENSIONS

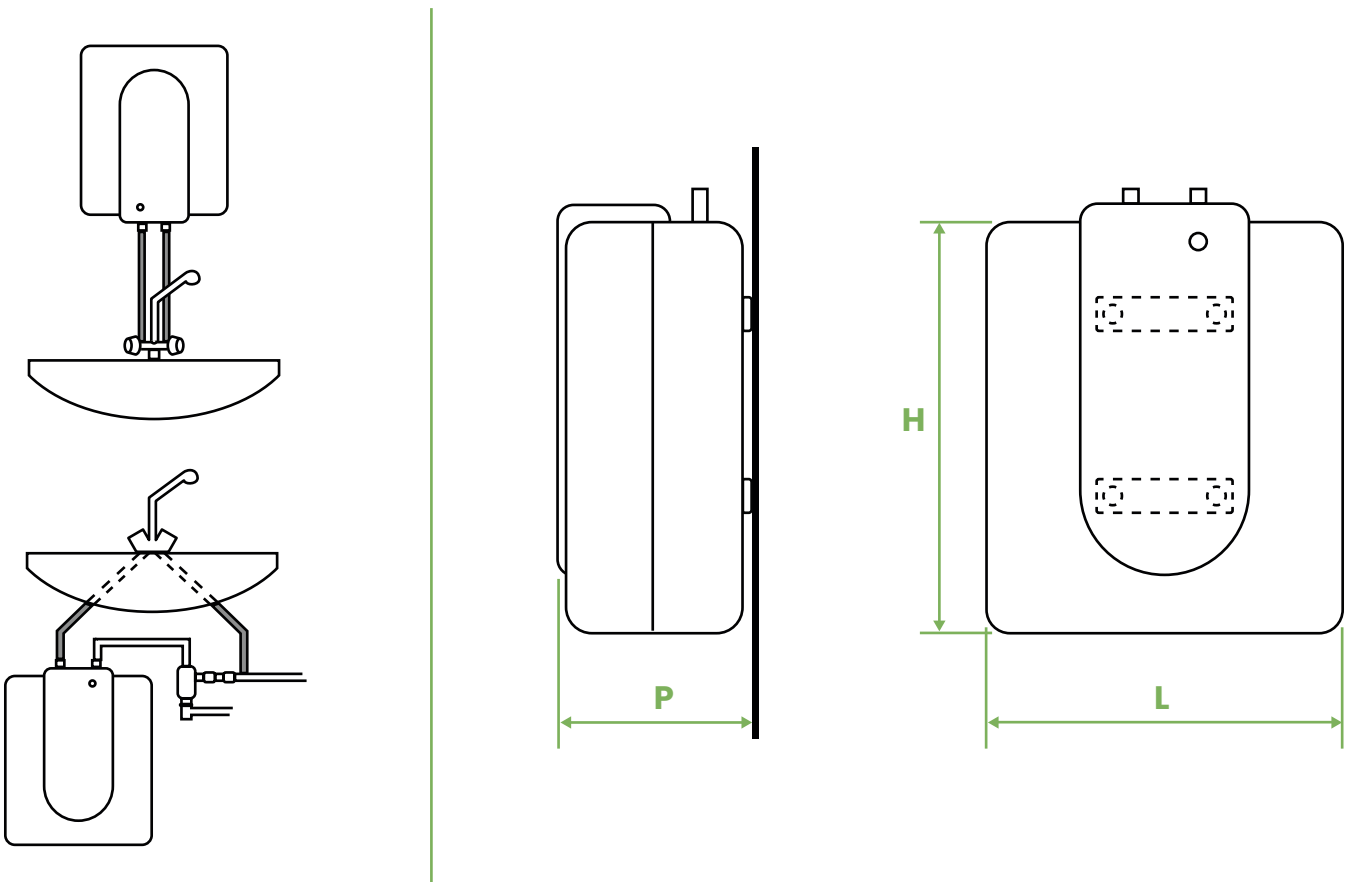

	H	L	P
A12 SP over-sink	410 mm	350 mm	220 mm
A12 ST under-sink	410 mm	350 mm	220 mm

A15

A15 SP / A15 ST

Electric storage water heater, small capacity Available both over-sink and under-sink version.



+ Why to choose it:

- Perfect to heat water for kitchen or sink use
- High versatility of installation, even into not-on-sight furniture
- Small dimensions require short period to heat water

TECHNICAL DATA

	A15 SP	A15 ST
Thermal Dispersiom 50° (KWh/24h)	0.38	0.38
Power (W)	1500	1500
Voltage (V)	230	230
Heating time (Δt 50°)	35'	35'
Max working temperature (C°)	60°	60°
Max working pressure (bar)	8	8
Protection against humidity	IPX4	IPX4
Insulation class	I	I
Profile	XXS	XXS
Energy Class	B	C

+ **INCREASED MAGNESIUM ANODE,**
FOR TOTAL PROTECTION AGAINST
VACANT CURRENTS

+ **GLASS ENAMELED**
TANK

+ **ABSENCE OF CFC;**
POLYURETHANE FOAM
FOR ECOLOGICAL THERMAL
INSULATION



**COPPER
HEATING ELEMENT**



**INSTALLATION
KIT**



**POLYURETHANE
FOAM CFC FREE**



**MAGNESIUM
ANODE**



**LED
CONTROL**



**ROHS
COMPONENT**



THERMOSTAT

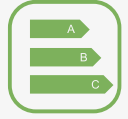

**ERP
2017**

DIMENSIONS

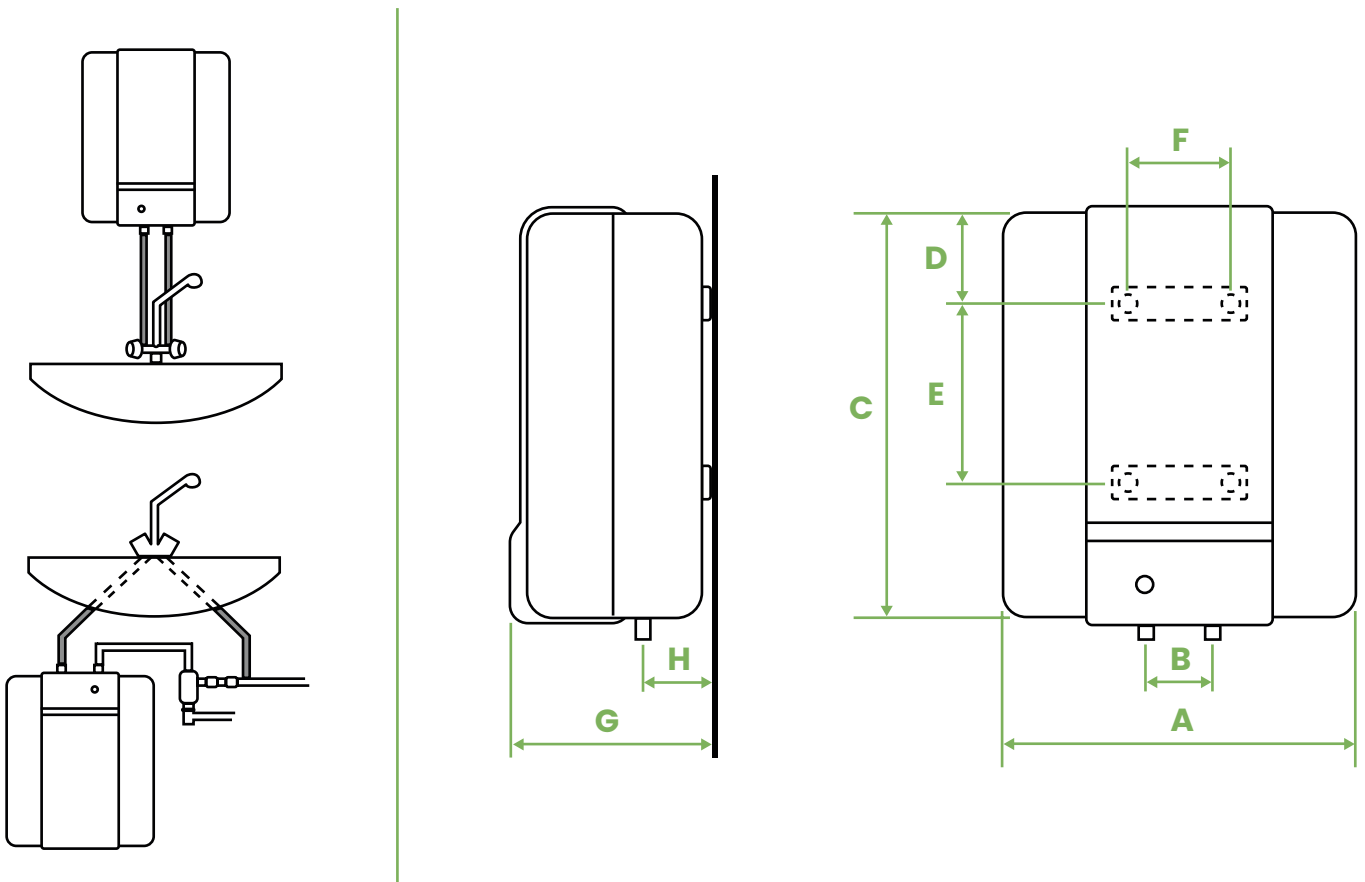

	H	L	P
A15 SP over-sink	410 mm	350 mm	260 mm
A15 ST under-sink	410 mm	350 mm	260 mm



Q

12 SP / 12 ST / 15 SP / 15 ST / 12 SP A

Electric storage water heater, small capacity. Available both over-sink and under-sink version. Available also with external regulation of temperature.

+ Why to choose it:

- Perfect to heat water for kitchen or sink use
- High versatility of installation, even into not-on-sight furniture
- Small dimensions require short period to heat water
- New design meets perfectly the new requirements of energy saving

TECHNICAL DATA

	Q12 SP	Q12 ST	Q15 SP	Q15 ST	Q12 SP A
Thermal Dispersiom 50° (KWh/24h)	0.38	0.38	0.42	0.42	0.38
Power (W)	1500	1500	1500	1500	1500
Voltage (V)	230	230	230	230	230
Heating time (Δt 50°)	28'	28'	35'	35'	28'
Max working temperature (C°)	65°	65°	65°	65°	45°
Max working pressure (bar)	8	8	8	8	8
Protection against humidity	IPX4	IPX4	IPX4	IPX4	IPX4
Insulation class	I	I	I	I	I
Profile	XXS	XXS	XXS	XXS	XXS
Energy Class	B	C	B	C	A

+ HIGH ENERGY EFFICIENCY

+ EXTERNAL REGULATION OF TEMPERATURE

+ ABSENCE OF CFC; POLYURETHANE FOAM FOR ECOLOGICAL THERMAL INSULATION



COPPER HEATING ELEMENT



THERMOSTAT



LED CONTROL



ROHS COMPONENT



MAGNESIUM ANODE



POLYURETHANE FOAM CFC FREE



INSTALLATION KIT



EXTERNAL REGULATION OF TEMPERATURE

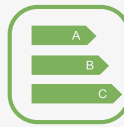

ERP 2017



INSPECTION FLANGE



ENVIRONMENT RESPECT

DIMENSIONS

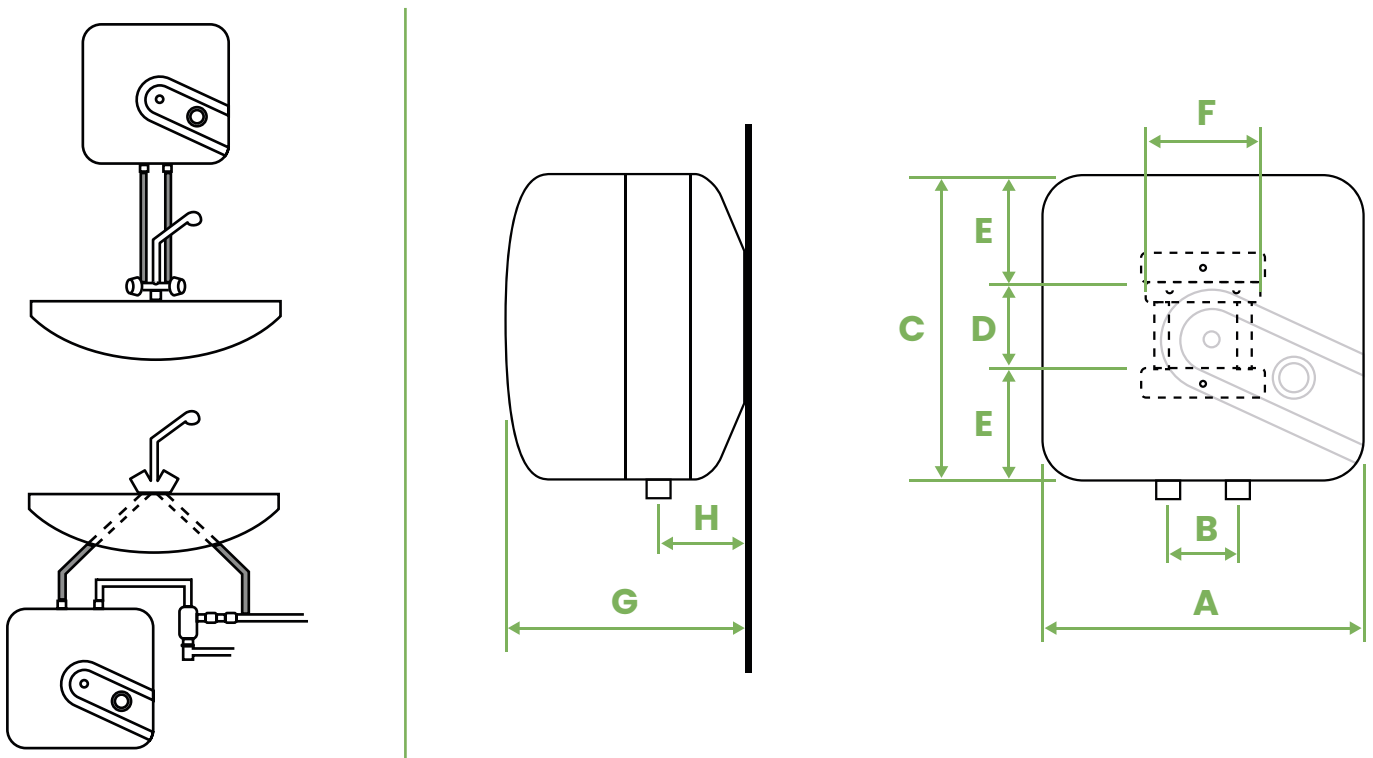

	A	B	C	D	E	F	G	H
Q12	360 mm	75 mm	360 mm	100 mm	130 mm	135 mm	255 mm	110 mm
Q15	360 mm	75 mm	360 mm	100 mm	130 mm	135 mm	290 mm	110 mm

B14



Electric storage water heater 14lt, "Doccetta"

+ Why to choose it:

- High versatility of installation, even into not-on-sight furniture
- Small dimensions require short period to heat water
- Double outlet to connect in various points for serving hot water
- Kit of mixer and shower hoses included
- Mixer to regulate the water's flow

TECHNICAL DATA

	B14
Thermal Dispersiom 50° (KWh/24h)	0.52
Power (W)	2000
Voltage (v)	230
Heating time (Δt 50°)	26'
Max working temperature (C°)	65°
Max working pressure (bar)	8
Protection against humidity	IPX4
Insulation class	I
Profile	XXS
Energy Class	B

- +** **DOUBLE OUTLET** FOR CONNECTION TO SEVERAL HOT WATER DELIVERY POINTS
- +** **KIT OF MIXER, HOSE AND SHOWER ARM** AS STANDARD
- +** **SINGLE LEVER MIXER** TO REGULATE THE WATER FLOW
- +** **ABSENCE OF CFC; POLYURETHANE FOAM** FOR ECOLOGICAL THERMAL INSULATION



DIMENSIONS

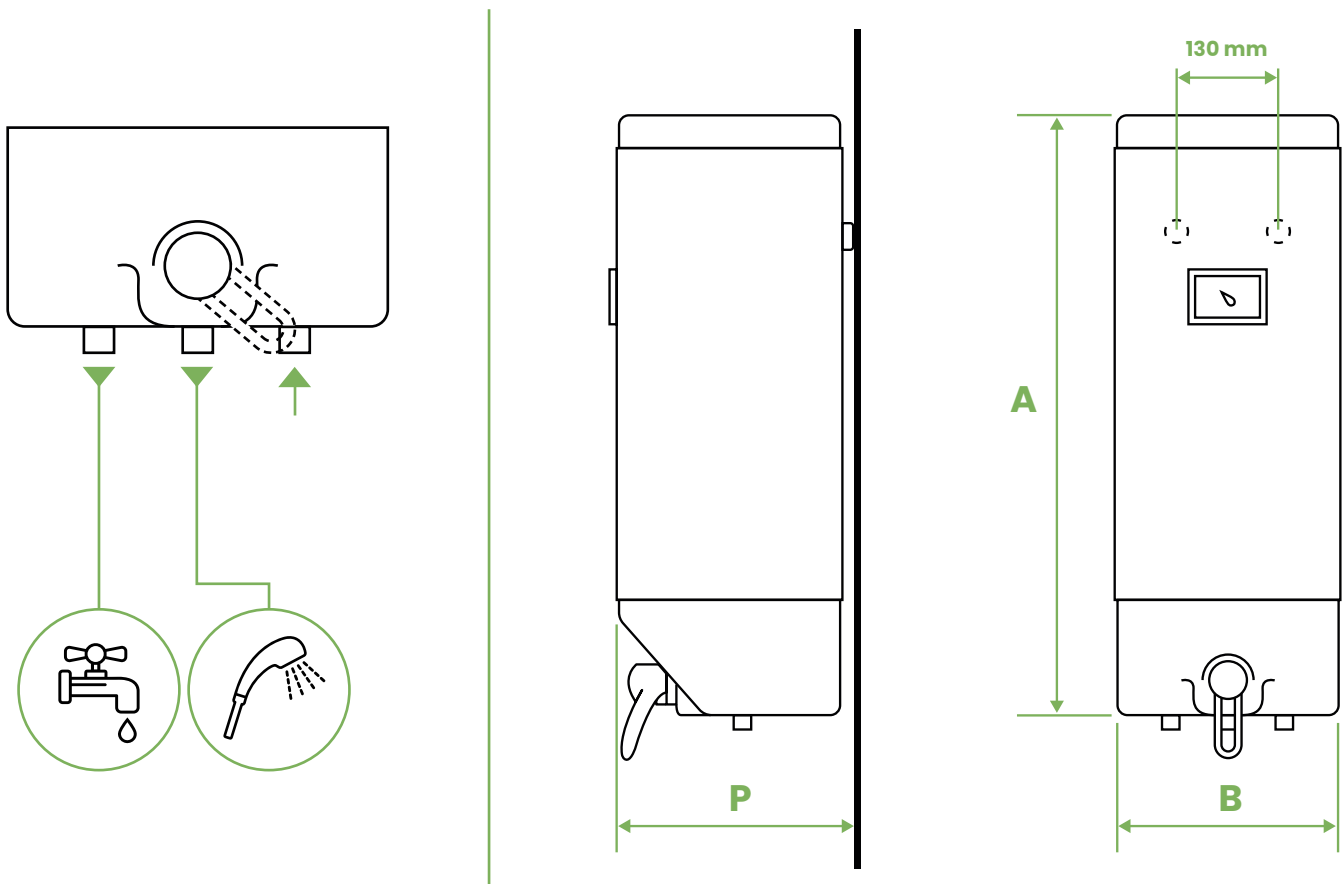

	A	B	P
B14	640 mm	230 mm	220 mm

B30



Electric storage water heater 30lt with external regulation of temperature.

+ Why to choose it:

- Perfect to heat water for kitchen or sink use
- High versatility of installation, even into not-on-sight furniture
- Small dimensions require short period to heat water

TECHNICAL DATA

	B30
Thermal Dispersiom 50° (KWh/24h)	0,7
Power (W)	1500
Voltage (V)	230
Heating time (Δt 50°)	70'
Max working temperature (C°)	65°
Max working pressure (bar)	8
Protection against humidity	IPX4
Insulation class	I
Profile	S
Energy Class	C

+ **INCREASED MAGNESIUM ANODE,**
FOR TOTAL PROTECTION AGAINST
VACANT CURRENTS

+ **GLASS ENAMELED**
TANK

+ **ABSENCE OF CFC;**
POLYURETHANE FOAM
FOR ECOLOGICAL THERMAL
INSULATION

+ **EXTERNAL REGULATION**
OF TEMPERATURE



**COPPER
HEATING ELEMENT**



THERMOSTAT



**LED
CONTROL**



**ROHS
COMPONENT**



**MAGNESIUM
ANODE**



**POLYURETHANE
FOAM CFC FREE**



**INSTALLATION
KIT**



**EXTERNAL REGULATION
OF TEMPERATURE**

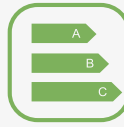

ERP 2017



**INSPECTION
FLANGE**



**ENVIRONMENT
RESPECT**

DIMENSIONS

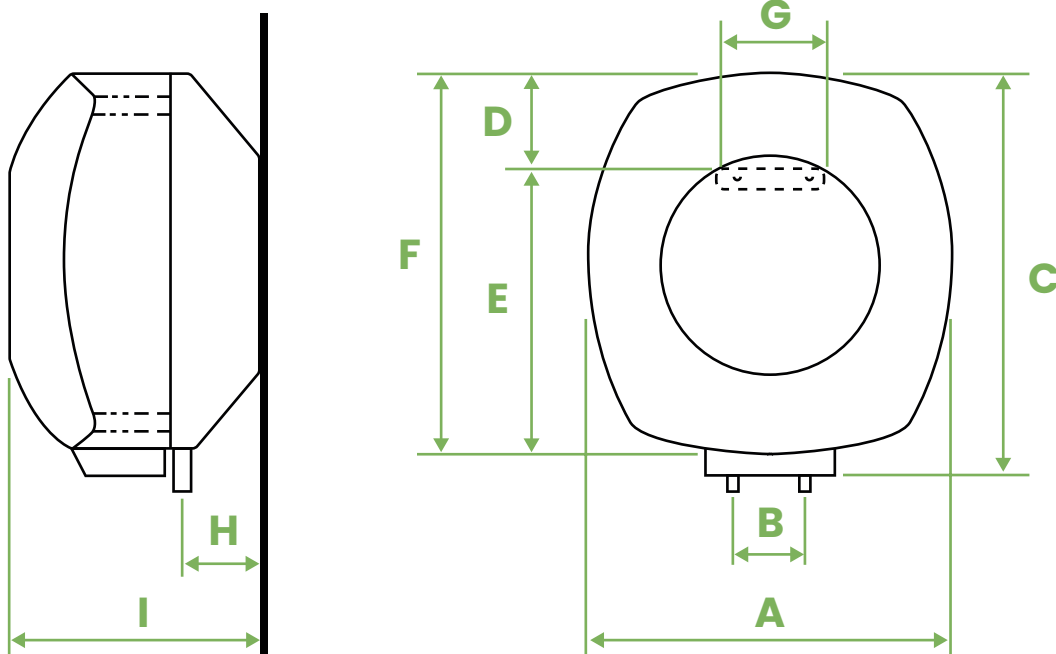

	A	B	C	D	E	F	G	H	I
B30	475 mm	100 mm	530 mm	120 mm	365 mm	485 mm	140 mm	105 mm	325 mm

C65



SMART C65

Electric storage water heater, double tank, Flat profile.

Available for vertical installation / horizontal (left), wall fixed.

+ Why to choose it:

- This product meets the needs of a space saving installation, optimizing spaces
- SMART thermostat controls one of the 2 tanks and optimizes energy consumptions
- The double tanks systems can give you hot water in half of the required standard time of normal storage water heater.

TECHNICAL DATA

	C65 SMART	C65 SMART
Thermal Dispersiom 50° (KWh/24h)	0,42	0,42
Power (W)	2x800	2x1200
Voltage (V)	230	230
Heating time (Δt 50°)	120'	80'
Max working temperature (C°)	65°	65°
Max working pressure (bar)	8	8
Protection against humidity	IPX4	IPX4
Insulation class	I	I
Profile	M	M
Energy Class	C	C



THERMOSTAT WITH SMART TECHNOLOGY TO MEMORIZE THE DAILY USE OF HOT WATER. PROGRAM THE OPTIMAL CONSUMPTION TO REDUCE ENERGY WASTE



FLAT DESIGN TO REDUCE THE OVERALL DIMENSIONS AND GUARANTEE A SPACE-SAVING INSTALLATION



ALSO POSSIBLE HORIZONTAL INSTALLATION (SX), TO ADAPT TO THE TIGHTEST SPACES!



COPPER HEATING ELEMENT

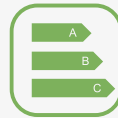

ERP 2017



INSTALLATION KIT



EXTERNAL REGULATION OF TEMPERATURE



MAGNESIUM ANODE



ROHS COMPONENT



POLYURETHANE FOAM CFC FREE



THERMOSTAT



ENVIRONMENT RESPECT

DIMENSIONI

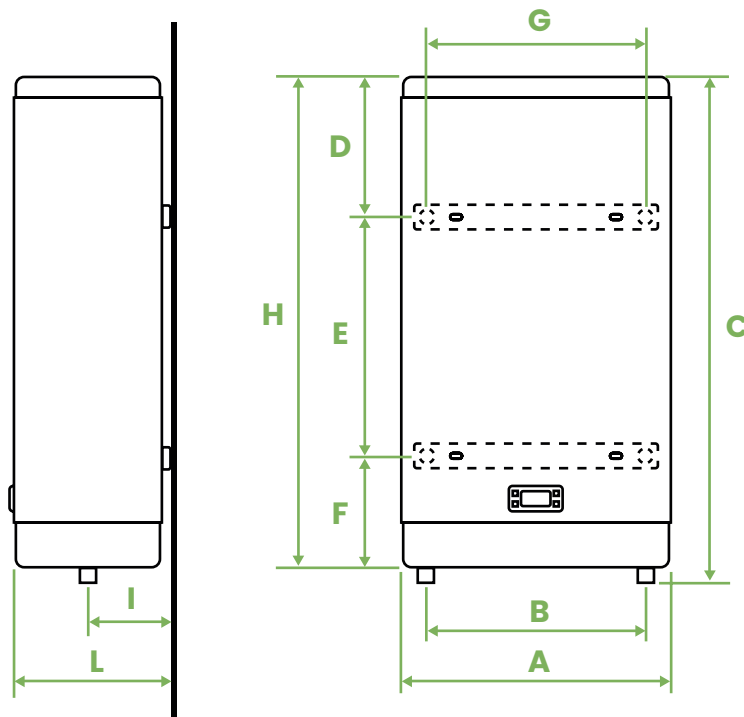

	A	B	C	D	E	F	G	H	I	L
C65 SMART	470 mm	400 mm	855 mm	225 mm	420 mm	210 mm	380 mm	875 mm	145 mm	275 mm
C65 SMART	470 mm	400 mm	855 mm	225 mm	420 mm	210 mm	380 mm	875 mm	145 mm	275 mm

ECO



60 / 80 / 100 *lt*

Electric storage water heater with augmented thermal insulation

+ Why to choose it:

The augmented thickness of the insulation (compared to classic models), makes this water heater the best answer to the new low consumption needs. The bigger "thermal coat" effect allows the water to be kept in temperature for a longer period of time long, giving off much less heat than to classic models.

This new product class guarantees the perfect combination of the needs of a lower energy consumption and the comfort of the hot water.

TECHNICAL DATA

	ECO60	ECO80	ECO100
Thermal Dispersiom 50° (KWh/24h)	0,79	0,97	1,18
Power (W)	1200	1200	1500
Voltage (v)	230	230	230
Heating time (Δt 50°)	175'	232'	245'
Max working temperature (C°)	65°	65°	65°
Max working pressure (bar)	8	8	8
Protection against humidity	IPX4	IPX4	IPX4
Insulation class	I	I	I
Profile	M	M	M
Energy Class	C	C	C

+ LESS THERMAL DISPERSION

+ ENHANCED THICKNESS

+ ENERGY COST SAVING

+ ABSENCE OF CFC;
POLYURETHANE FOAM
FOR ECOLOGICAL THERMAL
INSULATION



COPPER HEATING ELEMENT



THERMOSTAT



LED CONTROL



ROHS COMPONENT



MAGNESIUM ANODE



POLYURETHANE FOAM CFC FREE



ERP 2017



INSPECTION FLANGE



ENVIRONMENT RESPECT

DIMENSIONS

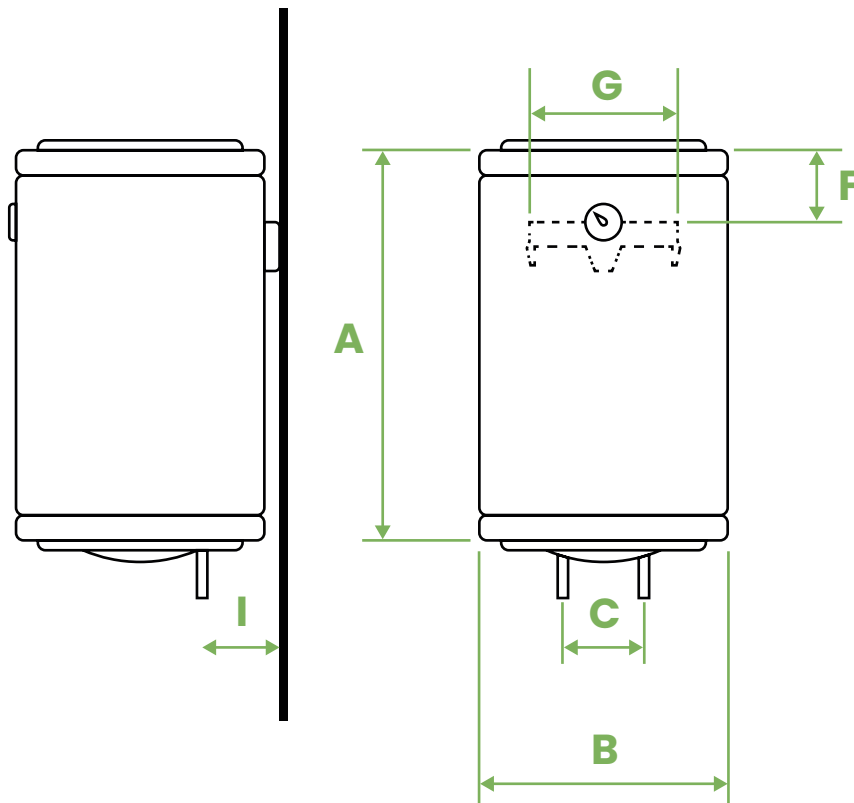

	A	B	C	F	G	I
ECO60	600 mm	460 mm	100 mm	130 mm	350 mm	130 mm
ECO80	760 mm	460 mm	100 mm	130 mm	350 mm	130 mm
ECO100	960mm	460 mm	100 mm	130 mm	350 mm	130 mm

ECO XL

60 / 80 *lt*

Electric storage water heater with augmented thermal insulation

+ Why to choose it:

The augmented thickness of the insulation (compared to classic models), makes this water heater the best answer to the new low consumption needs. The bigger "thermal coat" effect allows the water to be kept in temperature for a longer period of time long, giving off much less heat than to classic models.

This new product class guarantees the perfect combination of the needs of a lower energy consumption and the comfort of the hot water.









Augmented dimensions to increase even more the ECO comfort!



TECHNICAL DATA

	ECO XL 60	ECO XL 80
Thermal Dispersiom 50° (KWh/24h)	0,79	0,97
Power (W)	1200	1200
Voltage (V)	230	230
Heating time (Δt 50°)	145'	232'
Max working temperature (C°)	65°	65°
Max working pressure (bar)	8	8
Protection against humidity	IPX4	IPX4
Insulation class	I	I
Profile	M	M
Energy Class	C	C

- +** LESS THERMAL DISPERSION
- +** ENHANCED THICKNESS
- +** ENERGY COST SAVING
- +** ABSENCE OF CFC;
POLYURETHANE FOAM
FOR ECOLOGICAL THERMAL
INSULATION

 COPPER HEATING ELEMENT	 THERMOSTAT	 LED CONTROL	 ROHS COMPONENT
 MAGNESIUM ANODE	 POLYURETHANE FOAM CFC FREE	 INSPECTION FLANGE	 ENVIRONMENT RESPECT
 ERP 2017			

DIMENSIONS

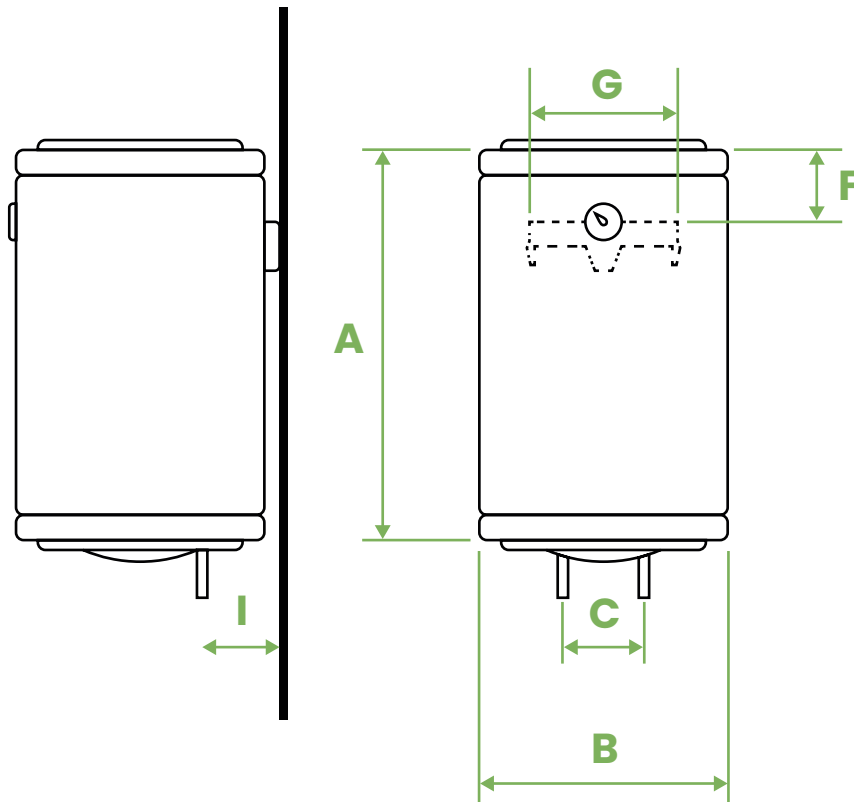

	A	B	C	F	G	I
ECO XL 60	510 mm	500 mm	100 mm	130 mm	350 mm	130 mm
ECO XL 80	640 mm	500 mm	100 mm	130 mm	350 mm	130 mm

SMART



60 / 80 / 100 *lt*

Electric fender with insulation increased and technology thermostat SMART

+ Why to choose it:

The smart thermostat that optimizes cycles heating, ensures the perfect combination of low energy consumption and hot water, always ready for use! The augmented thickness of the insulation (compared to classic models), makes this water heater the best answer to the new low consumption needs.

The SMART technology allows you to control the heating cycles even for longer periods of absence, with the possibility of ANTIFREEZE CYCLE and ANTI LEGIONEL CYCLE

TECHNICAL DATA

	SMART 60	SMART 80	SMART 100
Thermal Dispersiom 50° (KWh/24h)	0,79	0,97	1,18
Power (W)	1200	1200	1500
Voltage (v)	230	230	230
Heating time (Δt 50°)	175'	232'	245'
Max working temperature (C°)	65°	65°	65°
Max working pressure (bar)	8	8	8
Protection against humidity	IPX4	IPX4	IPX4
Insulation class	I	I	I
Profile	M	M	M
Energy Class	B	B	C

- +** **MEMORIZE** THE WATER WITHDRAWALS
- +** **CALCULATES THE DAILY REQUIREMENT** BASED ON YOUR CONSUMPTION
- +** **CONTROLS THE WATER HEATING PHASES** TO REDUCE HEAT LOSS AND OPTIMIZES THE AVAILABILITY OF HOT WATER
- +** **AUGMENTED INSULATION**



COPPER HEATING ELEMENT



THERMOSTAT



LED CONTROL



ROHS COMPONENT



MAGNESIUM ANODE



POLYURETHANE FOAM CFC FREE



LOW NOISE WORKING



ENVIRONMENT RESPECT



ERP 2017



INSPECTION FLANGE

DIMENSIONS

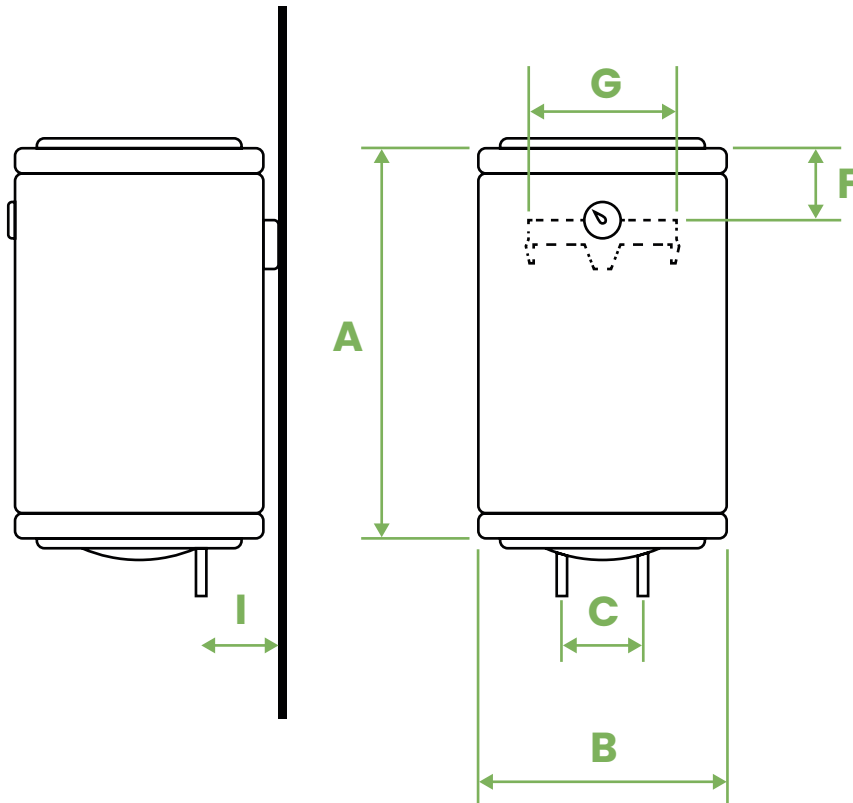

	A	B	C	F	G	I
SMART 60	600 mm	460 mm	100 mm	130 mm	350 mm	130 mm
SMART 80	760 mm	460 mm	100 mm	130 mm	350 mm	130 mm
SMART 100	960 mm	460 mm	100 mm	130 mm	350 mm	130 mm

SLIM



VERTICAL

20 / 30 / 45 / 60 lt

Electric water heater with "SLIM" profile, vertical installation

+ Why to choose it:

- To meet those needs for installation where smaller dimensions will be crucial.
- the special profile of the "SLIM" boiler guarantees a better heating performance compared to classic models
- the special profile of the "SLIM" boiler guarantees a better resistance to water pressure
- available with external regulation of temperature

TECHNICAL DATA

* the indicated power is the one suggested by the manufacturer for the best combination of performance / energy saving, other powers are also available on customer request

	SLIM 20	SLIM 30	SLIM 45	SLIM 60
Thermal Dispersiom 50° (KWh/24h)	0,56	0,69	0,72	0,78
Power (W)	1200	1200	1200	1200
Voltage (V)	230	230	230	230
Heating time (Δt 50°)	64'	75'	130'	175'
Max working temperature (C°)	65°	65°	65°	65°
Max working pressure (bar)	8	8	8	8
Protection against humidity	IPX4	IPX4	IPX4	IPX4
Insulation class	I	I	I	I
Profile	S	S	M	M
Energy Class	C	C	C	C

+ **INCREASED MAGNESIUM ANODE,**
FOR TOTAL PROTECTION AGAINST
VACANT CURRENTS

+ **GLASS ENAMELED**
TANK

+ **ABSENCE OF CFC;**
POLYURETHANE FOAM
FOR ECOLOGICAL THERMAL
INSULATION

+ **SPACE SAVING** PROFILE



**COPPER
HEATING ELEMENT**



**INSPECTION
FLANGE**

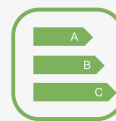

**ERP
2017**



**MAGNESIUM
ANODE**



**LED
CONTROL**



**ROHS
COMPONENT**



**POLYURETHANE
FOAM CFC FREE**



THERMOSTAT

DIMENSIONS

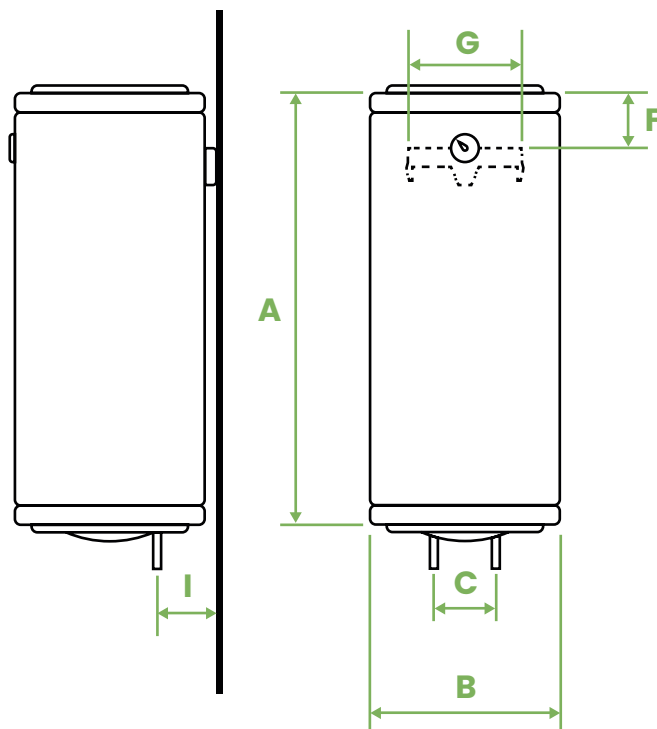

	A	B	C	F	G	I
SLIM 20	350 mm	370 mm	100 mm	130 mm	350 mm	90 mm
SLIM 30	450 mm	370 mm	100 mm	130 mm	350 mm	90 mm
SLIM 45	700 mm	370 mm	100 mm	130 mm	350 mm	90 mm
SLIM 60	850 mm	370 mm	100 mm	130 mm	350 mm	90 mm

SLIM

HORIZONTAL

45 / 60 *lt*

Electric water heater with "SLIM" profile, horizontal installation

+ Why to choose it:

- To meet those needs for installation where smaller dimensions will be crucial.
- the special profile of the "SLIM" boiler guarantees a better heating performance compared to classic models
- the special profile of the "SLIM" boiler guarantees a better resistance to water pressure

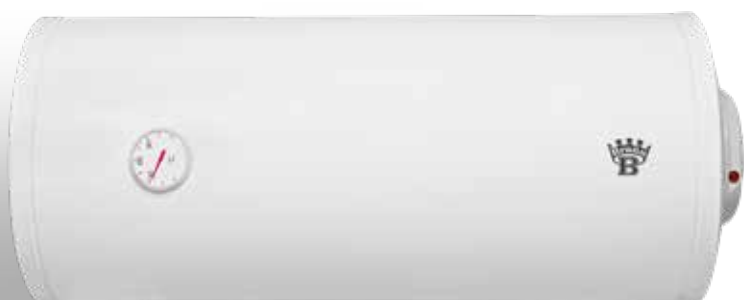

TECHNICAL DATA

* the indicated power is the one suggested by the manufacturer for the best combination of performance / energy saving, other powers are also available on customer request

	SLIM 45	SLIM 60
Thermal Dispersiom 50° (KWh/24h)	0,79	0,86
Power (W)	1500	1500
Voltage (V)	230	230
Heating time (Δt 50°)	130'	175'
Max working temperature (C°)	65°	65°
Max working pressure (bar)	8	8
Protection against humidity	IPX4	IPX4
Insulation class	I	I
Profile	M	M
Energy Class	C	C

+ **INCREASED MAGNESIUM ANODE,**
FOR TOTAL PROTECTION AGAINST
VACANT CURRENTS

+ **GLASS ENAMELED**
TANK

+ **ABSENCE OF CFC;**
POLYURETHANE FOAM
FOR ECOLOGICAL THERMAL
INSULATION

+ **SPACE SAVING** PROFILE



**COPPER
HEATING ELEMENT**



**INSPECTION
FLANGE**

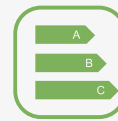

**ERP
2017**



**MAGNESIUM
ANODE**



**LED
CONTROL**



**ROHS
COMPONENT**



**POLYURETHANE
FOAM CFC FREE**



THERMOSTAT

DIMENSIONS

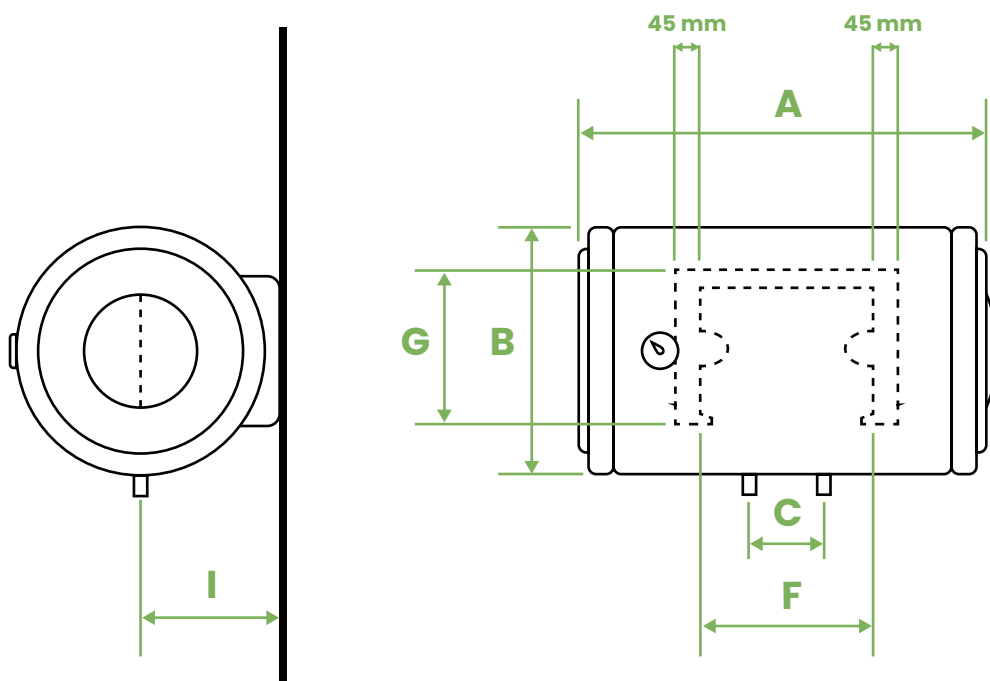

	A	B	C	F	G	I
SLIM 45	700 mm	370 mm	100 mm	425 mm	350 mm	200 mm
SLIM 60	850 mm	370 mm	100 mm	575 mm	350 mm	200 mm

SE



50 / 80 / 100 / 120 / 150 / 200 *lt*

Electric storage water heater, vertical wall installation. Available also with manual external regulation.

+ Why to choose it:

- It is the classic model, which has been around for years in Italian homes to satisfy the most various hot water needs.
- It is an easy installation product, which allows you to have hot water ready for use: ideal for treating yourself to a nice one relaxing and regenerating hot shower!

TECHNICAL DATA

* the indicated power is the one suggested by the manufacturer for the best combination of performance / energy saving, other powers are also available on customer request

	SE 50	SE 80	SE 100	SE 120	SE 150	SE 200
Thermal Dispersiom 50° (KWh/24h)	0,98	1,32	1,51	1,84	2,09	2,41
Power (W)	1200	1200	1500	1500	2000	2000
Voltage (v)	230	230	230	230	230	230
Heating time (Δt 50°)	145'	232'	245'	280'	310'	372'
Max working temperature (C°)	65°	65°	65°	65°	65°	65°
Max working pressure (bar)	8	8	8	8	8	8
Protection against humidity	IPX4	IPX4	IPX4	IPX4	IPX4	IPX4
Insulation class	I	I	I	I	I	I
Profile	M	M	M	L	XL	XL
Energy Class	C	C	C	C	C	C

+ **INCREASED MAGNESIUM ANODE,**
FOR TOTAL PROTECTION AGAINST
VACANT CURRENTS

+ **GLASS ENAMELED**
TANK

+ **ABSENCE OF CFC;**
POLYURETHANE FOAM
FOR ECOLOGICAL THERMAL
INSULATION



**COPPER
HEATING ELEMENT**



**INSPECTION
FLANGE**



**ERP
2017**



**MAGNESIUM
ANODE**



**LED
CONTROL**



**ROHS
COMPONENT**



**POLYURETHANE
FOAM CFC FREE**



THERMOSTAT

DIMENSIONS

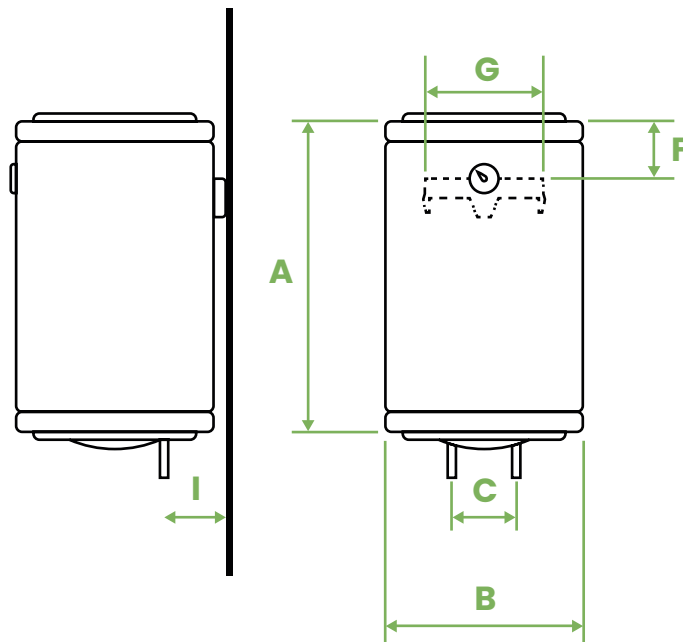

	A	B	C	F	G	I
SE 50	510 mm	460 mm	100 mm	130 mm	350 mm	130 mm
SE 80	700 mm	460 mm	100 mm	130 mm	350 mm	130 mm
SE 100	805 mm	460 mm	100 mm	130 mm	350 mm	130 mm
SE 120	1000 mm	460 mm	100 mm	130 mm	350 mm	130 mm
SE 150	935 mm	550 mm	100 mm	180 mm	350 mm	130 mm
SE 200	1105 mm	550 mm	100 mm	180 mm	350 mm	130 mm

SO

 50 / 80 / 100 / 120 / 150 / 200 *lt*

Electric storage water heater, horizontal wall installation. Available with electrical connection on the right or left, on request.

+ Why to choose it:

- It is the classic model, which has been around for years in Italian homes to satisfy the most various hot water needs.

- It is an easy installation product, which allows you to have hot water ready for use: ideal for treating yourself to a nice one relaxing and regenerating hot shower!

* the indicated power is the one suggested by the manufacturer for the best combination of performance / energy saving, other powers are also available on customer request

TECHNICAL DATA

	SO 50	SO 80	SO 100	SO 120	SO 150	SO 200
Thermal Dispersiom 50° (KWh/24h)	1,11	1,61	1,66	2,02	2,29	2,55
Power (W)	1500	1500	1500	1500	2000	2000
Voltage (V)	230	230	230	230	230	230
Heating time (Δt 50°)	145'	232'	245'	280'	310'	372'
Max working temperature (C°)	65°	65°	65°	65°	65°	65°
Max working pressure (bar)	8	8	8	8	8	8
Protection against humidity	IPX4	IPX4	IPX4	IPX4	IPX4	IPX4
Insulation class	I	I	I	I	I	I
Profile	M	M	M	L	XL	XL
Energy Class	C	C	C	C	C	C

+ **INCREASED MAGNESIUM ANODE,**
FOR TOTAL PROTECTION AGAINST
VACANT CURRENTS

+ **GLASS ENAMELED**
TANK

+ **ABSENCE OF CFC;**
POLYURETHANE FOAM
FOR ECOLOGICAL THERMAL
INSULATION

+ HUMIDITY PROTECTION CLASS
IPX4



**COPPER
HEATING ELEMENT**



**INSPECTION
FLANGE**



**ENVIRONMENT
RESPECT**



**MAGNESIUM
ANODE**



**LED
CONTROL**



**ROHS
COMPONENT**



**POLYURETHANE
FOAM CFC FREE**



THERMOSTAT

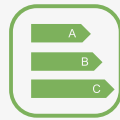

**ERP
2017**

DIMENSIONS

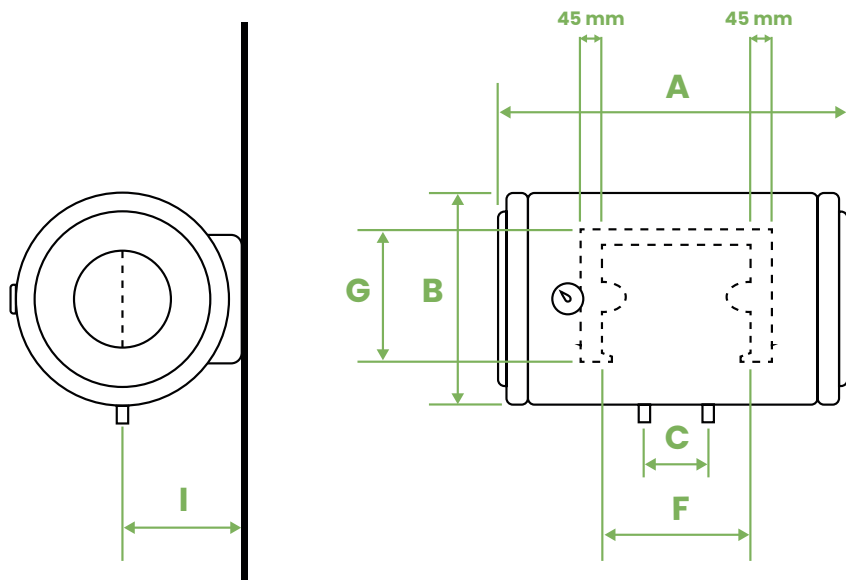

	A	B	C	F	G	I
SO 50	510 mm	460 mm	100 mm	125 mm	350 mm	240 mm
SO 80	700 mm	460 mm	100 mm	330 mm	350 mm	240 mm
SO 100	805 mm	460 mm	100 mm	435 mm	350 mm	240 mm
SO 120	1000 mm	460 mm	100 mm	510 mm	350 mm	240 mm
SO 150	935 mm	550 mm	140 mm	450 mm	350 mm	285 mm
SO 200	1105 mm	550 mm	140 mm	640 mm	350 mm	285 mm

SEP



150 / 200 / 300 *lt*

Electric water heater for industrial use,
basement / floor installation

+ Why to choose it:

- Product designed for industrial use or to satisfy larger needs for heating water hot (e.g. showers, changing rooms, gyms) for a sanitary use.
- The basement installation allows greater product stability

TECHNICAL DATA

	SEP 150	SEP 200	SEP 300
Thermal Dispersiom 50° (KWh/24h)	12,92	12,92	17,23
Power (W)	2000	2000	3000
Voltage (V)	230	230	230
Heating time (Δt 50°)	310'	372'	350'
Max working temperature (C°)	65°	65°	65°
Max working pressure (bar)	8	8	8
Protection against humidity	IPX4	IPX4	IPX4
Insulation class	I	I	I
Profile	L	XL	XL
Energy Class	C	C	C

+ **INCREASED MAGNESIUM ANODE,**
FOR TOTAL PROTECTION AGAINST
VACANT CURRENTS

+ **GLASS ENAMELED**
TANK

+ **ABSENCE OF CFC;**
POLYURETHANE FOAM
FOR ECOLOGICAL THERMAL
INSULATION

+ HUMIDITY PROTECTION CLASS
IPX4



**COPPER
HEATING ELEMENT**



**ROHS
COMPONENT**



THERMOSTAT



**MAGNESIUM
ANODE**



**LED
CONTROL**



**POLYURETHANE
FOAM CFC FREE**

DIMENSIONS

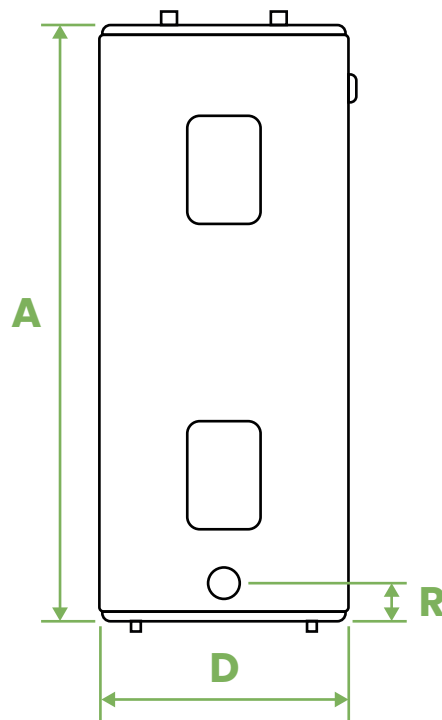

	A	D	R
SEP 150	930 mm	550 mm	200 mm
SEP 200	1100 mm	550 mm	200 mm
SEP 300	1750 mm	550 mm	200 mm



02. **WOOD BOILERS**



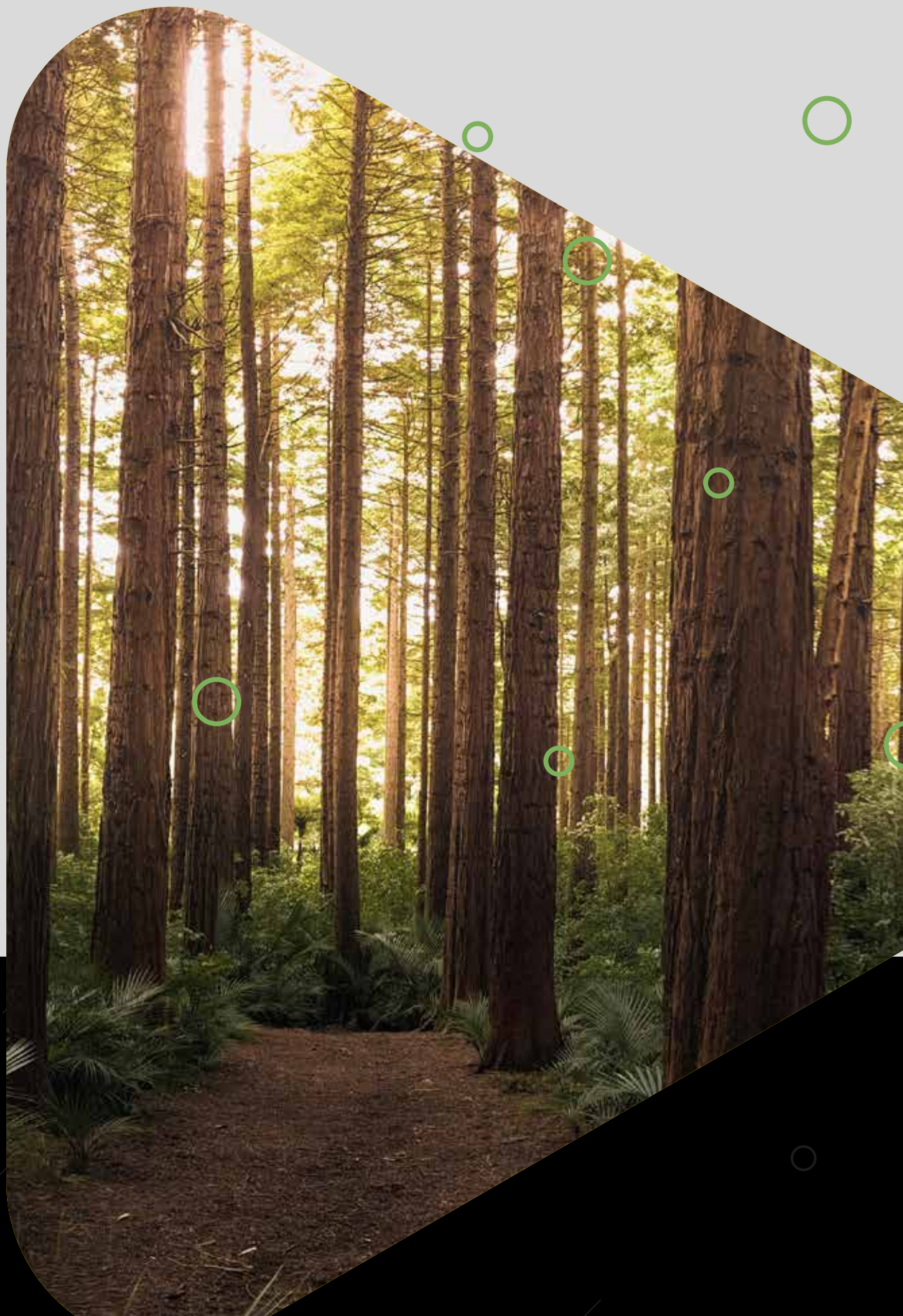

SL/SX/SZ



Wood-burning (SL)
 Wood - Electric combined (SX)
 Wood - Electric - thermo combined (SZ)

Vertical wood-fired water heater,
 installation to base.

+ Why to choose it:

It is one of the first versions conceived for the water heating for sanitary use, when still electricity and gas they were a luxury for the few. Satisfy the most various needs, also assisted by electricity (SX) or also from serpentine for the exchange of heat (SZ). Ideal product for mountain areas or wooded, provides hot water with a zero or negligible electricity consumption.

TECHNICAL DATA

	SL 80	SX 80	SZ 80
Thermal Dispersiom 50° (KWh/24h)	-	-	8.1
Power (W)	-	1200	1200
Voltage (V)	-	230	230
Surface heat exchanger (mq)	-	-	0,26
Max working temperature (C°)	75°	75°	75°
Max working pressure (bar)	8	8	8
Protection against humidity	IPX4	IPX4	IPX4
Insulation class	I	I	I

Yield heat exchanger of SZ 80 model

S mq	0,245
Load capacity mc/h	0,57
Kw eff. Δt 35° C	8.1
Load loss MBAR	26

+ AVAILABLE ALSO ONLY **WOOD FUNCTIONING**



COPPER HEATING ELEMENT



THERMOSTAT



LED CONTROL



ROHS COMPONENT

+ AVAILABLE WITH **HEATING ELEMENT AND THERMOSTAT**



MAGNESIUM ANODE

+ AVAILABLE WITH **HEAT EXCHANGER COMBINED WITH HEATING ELEMENT**

DIMENSIONS

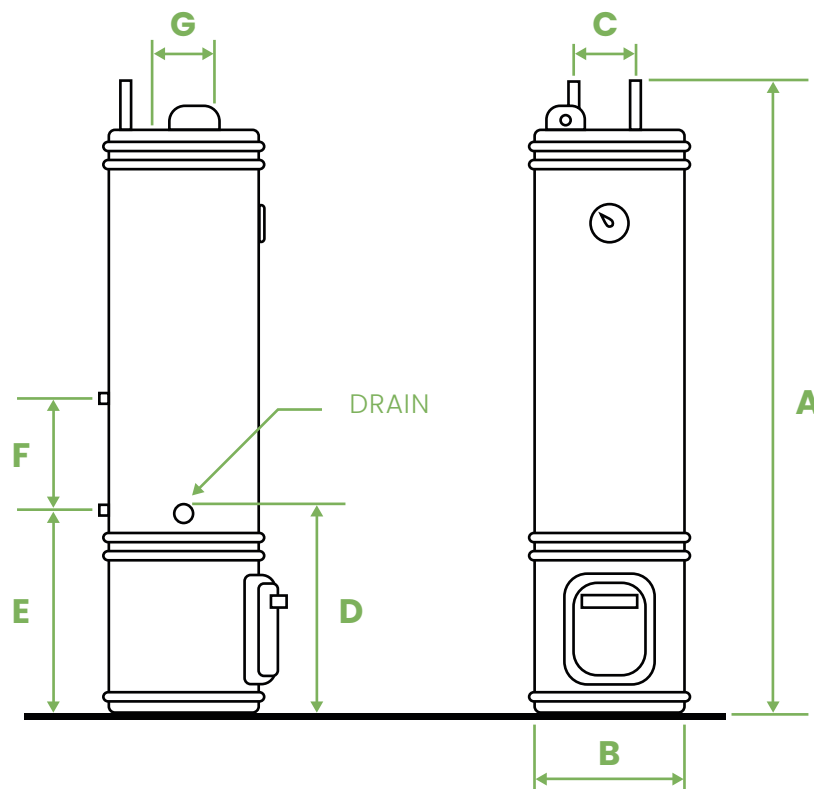

	A	B	C	D	E	F	G
SL 80	1400 mm	340 mm	100 mm	400 mm	500 mm	265 mm	100 mm
SX 80	1400 mm	340 mm	100 mm	400 mm	500 mm	265 mm	100 mm
SZ 80	1400 mm	340 mm	100 mm	400 mm	500 mm	265 mm	100 mm



x



03. THERMO COMBINED WATER HEATERS



ST



50 / 80 / 100 / 120 / 150 / 200 *lt*

Thermoelectric water heater
with serpentine
Vertical (right or left coil connections
of your choice)

+ Why to choose it:

- It was created to be combined with the system central heating of the house, so as to benefit from the heat exchange indirect, and reduce energy consumption.
- It has a classic resistance in support of the heat released by the internal coil, to bring the water up to temperature desired

* refers to electric operation only, without thermal energy

TECHNICAL DATA

	ST50	ST80	ST100	ST120	ST150	ST200
Thermal Dispersiom 50° (KWh/24h)	0,98	1,32	1,51	1,84	2,09	2,41
Power (W)	1200	1200	1500	1500	2000	2000
Voltage (V)	230	230	230	230	230	230
Heating time (Δt 50°)	145'	232'	245'	280'	310'	372'
Max working temperature (C°)	65	65	65	65	65	65
Max working pressure (bar)	8	8	8	8	8	8
Protection against humidity	IPX4	IPX4	IPX4	IPX4	IPX4	IPX4
Insulation class	I	I	I	I	I	I
Profile	M	M	M	L	XL	XL
Energy Class	C	C	C	C	C	C

EFFICIENCY COIL / HEAT EXCHANGER

LOAD MAX 80%

S mq	0,197	0,258	0,258	0,258	0,296	0,296
Load capacity mc/h	0,46	0,6	0,6	0,6	0,68	0,68
Kw eff. Δt 35° C	6,5	8,5	8,5	8,5	9,8	9,8
Load loss MBAR	17	30	30	30	38	38
Exchanger connections	1/2" FEMALE	1/2" FEMALE	1/2" FEMALE	1/2" FEMALE	1/2" FEMALE	1/2" FEMALE



PRODUCT EQUIPPED WITH INTERNAL COIL TO EXPLOIT THE HEAT EXCHANGE OF THE HEATING SYSTEM



GLASS ENAMELED TANK



ABSENCE OF CFC; POLYURETHANE FOAM FOR ECOLOGICAL THERMAL INSULATION



HUMIDITY PROTECTION CLASS IPX4



COPPER HEATING ELEMENT



THERMOSTAT



LED CONTROL



ROHS COMPONENT



MAGNESIUM ANODE



POLYURETHANE FOAM CFC FREE



INSPECTION FLANGE

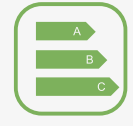

ERP 2017

DIMENSIONS

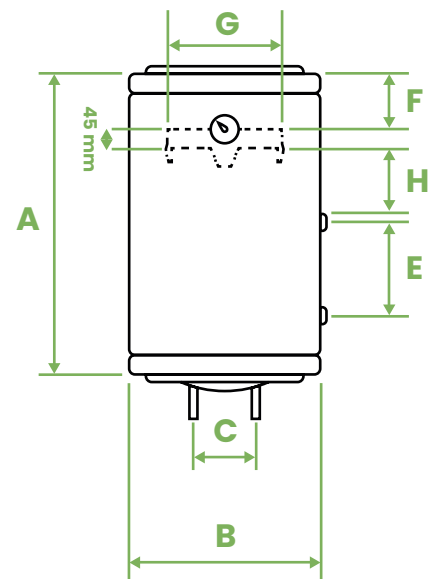
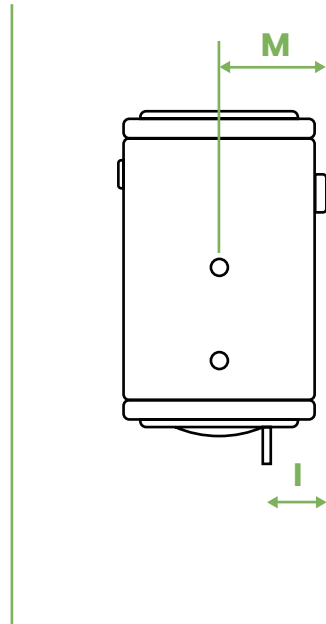
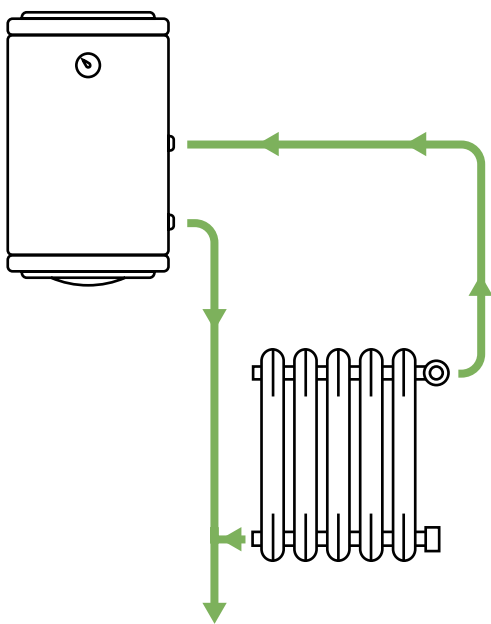

	A	B	C	E	F	G	H	I	M
ST 50	510 mm	460 mm	100 mm	175 mm	130 mm	350 mm	20 mm	130 mm	240 mm
ST 80	700 mm	460 mm	100 mm	265 mm	130 mm	350 mm	40 mm	130 mm	240 mm
ST 100	805 mm	460 mm	100 mm	265 mm	160 mm	350 mm	180 mm	130 mm	240 mm
ST 120	1000 mm	460 mm	100 mm	265 mm	170 mm	350 mm	340 mm	130 mm	240 mm
ST 150	935 mm	550 mm	140 mm	350 mm	180 mm	350 mm	140 mm	130 mm	285 mm
ST 200	1105 mm	550 mm	140 mm	350 mm	180 mm	350 mm	280 mm	130 mm	285 mm

ST/U



80 / 100 *lt*

Thermoelectric water heater
 with serpentine
 Universal (ambidextrous attacks)

+ Why to choose it:

- It was created to be combined with the system central heating of the house, so as to benefit from the heat exchange indirect, and reduce energy consumption.
- It has a classic resistance in support of the heat released by the internal coil, for bring the water to the desired temperature.

TECHNICAL DATA

* refers to electric operation only, without thermal energy

	STU 80	STU 100
Thermal Dispersiom 50° (KWh/24h)	1,32	1,51
Power (W)	1200	1500
Voltage (V)	230	230
Heating time (Δt 50°)	232'	245'
Max working temperature (C°)	65	65
Max working pressure (bar)	8	8
Protection against humidity	IPX4	IPX4
Insulation class	I	I
Profile	M	M
Energy Class	C	C

EFFICIENCY COIL / HEAT EXCHANGER

LOAD MAX 80%

S mq	0,258	0,258
Load capacity mc/h	0,6	0,6
Kw eff. Δt 35° C	8,5	8,5
Load loss MBAR	30	30
Exchanger connections	1/2" FEMALE	1/2" FEMALE



PRODUCT EQUIPPED WITH INTERNAL COIL TO EXPLOIT THE HEAT EXCHANGE OF THE HEATING SYSTEM



GLASS ENAMELED TANK



ABSENCE OF CFC; POLYURETHANE FOAM FOR ECOLOGICAL THERMAL INSULATION



HUMIDITY PROTECTION CLASS IPX4



COPPER HEATING ELEMENT



THERMOSTAT



LED CONTROL



ROHS COMPONENT



MAGNESIUM ANODE



POLYURETHANE FOAM CFC FREE



INSPECTION FLANGE



ERP 2017

DIMENSIONS

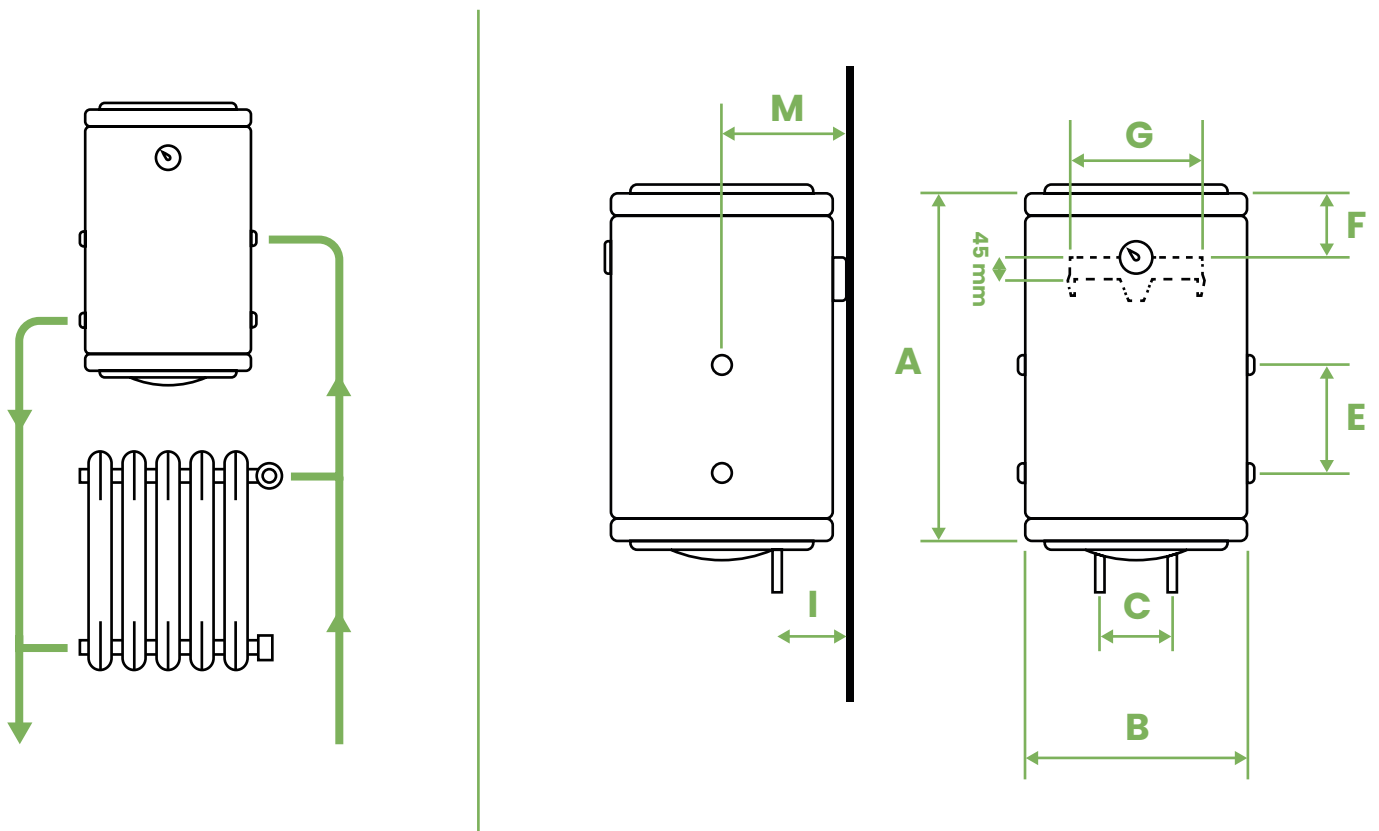

	A	B	C	E	F	G	I	M
STU 80	700 mm	460 mm	100 mm	265 mm	130 mm	350 mm	130 mm	240 mm
STU 100	805 mm	460 mm	100 mm	265 mm	130 mm	350 mm	130 mm	240 mm

STX



80 / 100 / 120 / 150 / 200 *lt*

Thermoelectric water heater
with heat exchanger coil elliptical
With right (DX) or left (SX) connections at
Choice

+ Why to choose it:

- Presence of Sensor Tube for control Temperature
- Possibility of connection to systems of centralized warming
- Possibility of connection with systems a Solar Panel
- Possibility of connection to pellet stoves
- High performance elliptical coil for heat exchange

* refers to electric operation only, without thermal energy

TECHNICAL DATA

	STX 80	STX 100	STX 120	STX 150	STX 200
Thermal Dispersiom 50° (KWh/24h)	1,32	1,51	1,84	2,09	2,42
Power (W)	1200	1500	1500	2000	2000
Voltage (V)	230	230	230	230	230
Heating time (Δt 50°)	232'	245'	280'	310'	472'
Max working temperature (C°)	65	65	65	65	65
Max working pressure (bar)	8	8	8	8	8
Protection against humidity	IPX4	IPX4	IPX4	IPX4	IPX4
Insulation class	I	I	I	I	I
Profile	M	M	L	XL	XL
Energy Class	C	C	C	C	C

EFFICIENCY COIL / HEAT EXCHANGER

LOAD MAX 80%

	STX 80	STX 100	STX 120	STX 150	STX 200
S mq	0,459	0,714	0,714	0,951	0,951
Load capacity mc/h	1,03	1,6	1,6	2,13	2,13
Kw eff. Δt 35° C	15,5	24,1	24,1	32,2	32,2
Load loss MBAR	330	800	800	1421	1421
Exchanger connections	1/2" FEMALE	1/2" FEMALE	1/2" FEMALE	1/2" FEMALE	1/2" FEMALE

+ HIGH PERFORMANCE ELLIPTICAL COIL FOR HEAT EXCHANGE

+ GLASS ENAMELED TANK

+ ABSENCE OF CFC; POLYURETHANE FOAM FOR ECOLOGICAL THERMAL INSULATION

+ HUMIDITY PROTECTION CLASS IPX4



COPPER HEATING ELEMENT



THERMOSTAT



LED CONTROL



ROHS COMPONENT



MAGNESIUM ANODE



POLYURETHANE FOAM CFC FREE



INSPECTION FLANGE



ENVIRONMENT RESPECT

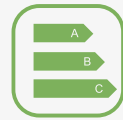

ERP 2017

DIMENSIONS

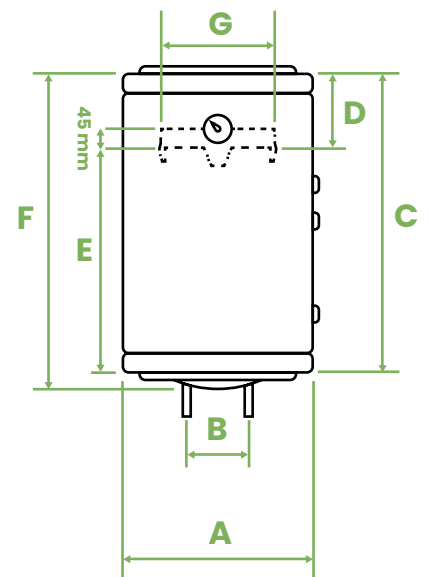
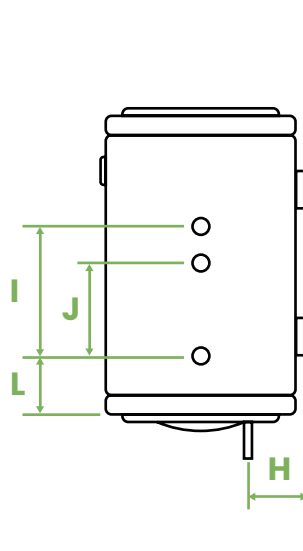
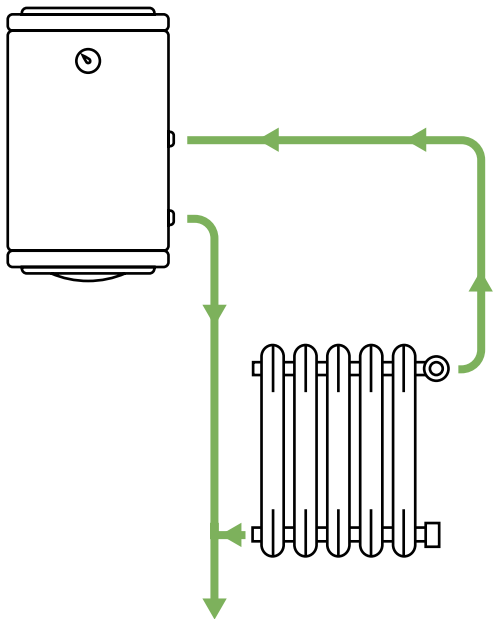

	A	B	C	D	E	F	G	H	I	J	L
STX 80	460 mm	100 mm	700 mm	155 mm	610 mm	765 mm	350 mm	115 mm	265 mm	135 mm	185 mm
STX 100	460 mm	100 mm	805 mm	185 mm	685 mm	870 mm	350 mm	115 mm	350 mm	215 mm	185 mm
STX 120	460 mm	100 mm	1000 mm	195 mm	870 mm	1065 mm	350 mm	115 mm	350 mm	215 mm	185 mm
STX 150	550 mm	140 mm	935 mm	205 mm	795 mm	1000 mm	350 mm	115 mm	350 mm	230 mm	225 mm
STX 200	550 mm	140 mm	1105 mm	205 mm	965 mm	1170 mm	350 mm	115 mm	350 mm	230 mm	225 mm

SO/T

 80 / 100 / 120 / 150 / 200 *lt*

Thermoelectric water heater
 with serpentine
 Horizontal (right serpentine connections or
 left at choice)

+ Why to choose it:

- It was created to be combined with the system central heating of the house, so as to benefit from the heat exchange indirect, and reduce energy consumption.
- It has a classic resistance in support of the heat released by the internal coil, to bring the water up to temperature desired

* refers to electric operation only, without thermal energy

TECHNICAL DATA

	SO/T 80	SO/T 100	SO/T 120	SO/T 150	SO/T 200
Thermal Dispersion 50° (KWh/24h)	1,61	1,66	2,02	2,29	2,55
Power (W)	1500	1500	1500	2000	2000
Voltage (V)	230	230	230	230	230
Heating time (Δt 50°)	232'	245'	280'	310'	372'
Max working temperature (C°)	65	65	65	65	65
Max working pressure (bar)	8	8	8	8	8
Protection against humidity	IPX4	IPX4	IPX4	IPX4	IPX4
Insulation class	I	I	I	I	I
Profile	M	M	L	XL	XL
Energy Class	C	C	C	C	C

EFFICIENCY COIL / HEAT EXCHANGER

LOAD MAX 80%

S mq	0,258	0,258	0,258	0,296	0,296
Load capacity mc/h	0,6	0,6	0,6	0,68	0,68
Kw eff. Δt 35° C	8,5	8,5	8,5	9,8	9,8
Load loss MBAR	30	30	30	38	38
Exchanger connections	1/2" FEMALE	1/2" FEMALE	1/2" FEMALE	1/2" FEMALE	1/2" FEMALE



PRODUCT EQUIPPED WITH INTERNAL COIL TO EXPLOIT THE HEAT EXCHANGE OF THE HEATING SYSTEM



GLASS ENAMELED TANK



ABSENCE OF CFC; POLYURETHANE FOAM FOR ECOLOGICAL THERMAL INSULATION



HUMIDITY PROTECTION CLASS IPX4



COPPER HEATING ELEMENT



THERMOSTAT



LED CONTROL



ROHS COMPONENT



MAGNESIUM ANODE



POLYURETHANE FOAM CFC FREE



INSPECTION FLANGE



ERP 2017

DIMENSIONS

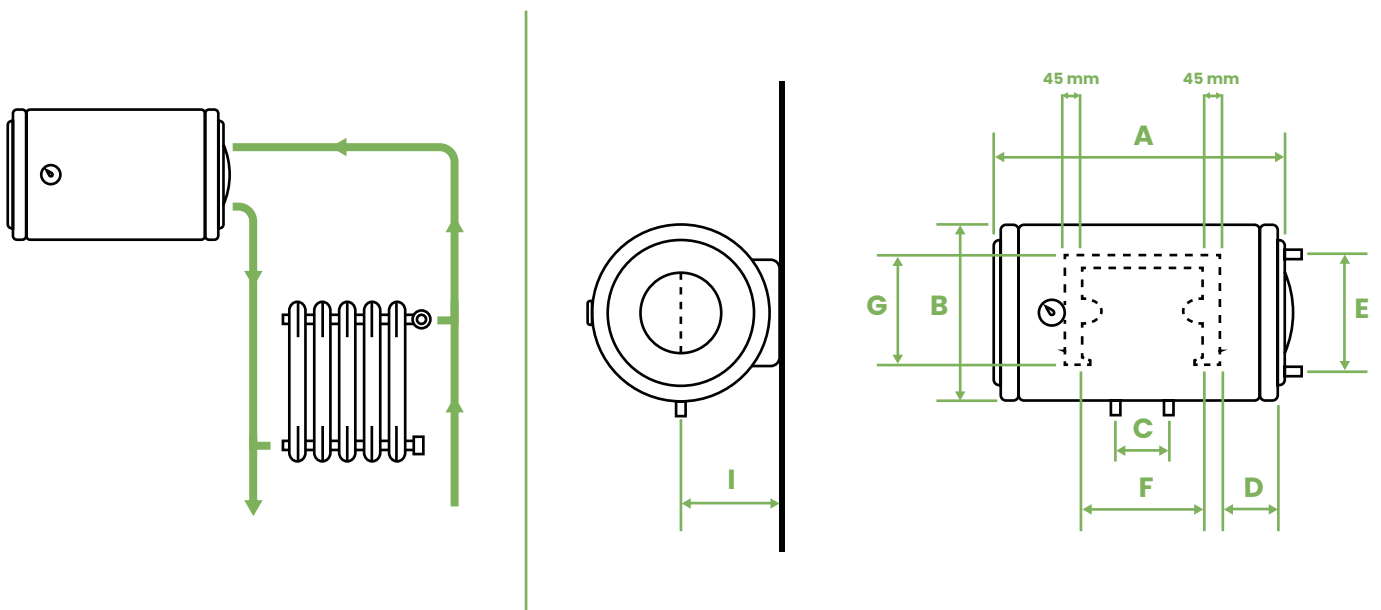

	A	B	C	D	E	F	G	I
so/T 80	700 mm	460 mm	100 mm	145 mm	260 mm	330 mm	350 mm	240 mm
so/T 100	805 mm	460 mm	100 mm	145 mm	280 mm	435 mm	350 mm	240 mm
so/T 120	1000 mm	460 mm	100 mm	210 mm	280 mm	510 mm	350 mm	240 mm
so/T 150	935 mm	550 mm	140 mm	207 mm	365 mm	450 mm	350 mm	285 mm
so/T 200	1105 mm	550 mm	140 mm	187 mm	365 mm	640 mm	350 mm	285 mm



04. BUFFER TANKS

WHAT ARE THEY FOR:

Inertial storage in the first heat pumps hydronic with on-off operation, had the main function of reducing the number of cycles of on and off and had a relationship between maximum compressor power and volume of accumulation, of about 10/15 liters for each KW.

Today the compressors are inverters, the pumps of heat have a wide range of smoothness between minimum and maximum power yields to the system, and manufacturers still continue to demand the presence in the system of an inertial storage however, with much lower liter values.

HOW IT'S SIZED:

In the heat pump installation manuals could be indicated, the volume of water minimum to be prepared in the system, to do in so that the pdc works regularly.

We also take into account the presence of valves, be they solenoid valves or thermostatic (thermostatic), therefore today the systems are with variable water volume, the minimum quota of fluid is guaranteed by ours accumulation, from Charger, even when some or many parts of the system result hydraulically closed or partially closed.



WHAT IS A BUFFER TANK?

Our CHARGER is a BUFFER TANK in steel whose function is to increase the quantity of heat transfer fluid (water) contained in the pump operated system of hydronic heat (heat pump) Where is the water that carries energy for heating or cooling.

The BUFFER TANK, in the first pumps of hydronic heat with on-off operation, had the function of reducing the number of on and off cycles and had a ratio of maximum power compressor and storage volume, di about 10/15 liters for each KW.

Today the compressors are inverters and the heat pumps have a wide range smoothness between minimum power and maximum yield to the plant. The builders and plumbers however continue to request the presence in the system of an accumulation inertial with lower volume values, compared to the classic buffer tanks.

It is to meet these needs that it is the CHARGER RANGE is born.

The systems must contain a minimum Quantity of liters of water per Kw of power, as specified in the table, and the presence of thermal accumulation is essential to allow it to adjust the functioning even at low thermal load, of the system.

How many liters of water per kW of power do the systems contain?

steel radiators	25 / 30 lt per KW
aluminium radiators	6 / 8 lt per KW
fan coils implants	0.4 / 0.8 lt per KW
Implants with radiant heat exchangers	8 / 12 lt per KW

The buffer tanks ARE NOT GLASS ENAMELED because they are designed for the accumulation of a water closed circuit (technique) where no electrolytic currents are developed (which could eventually damage the tank).

The product has also been designed to contain a non-hazardous glycol solution.

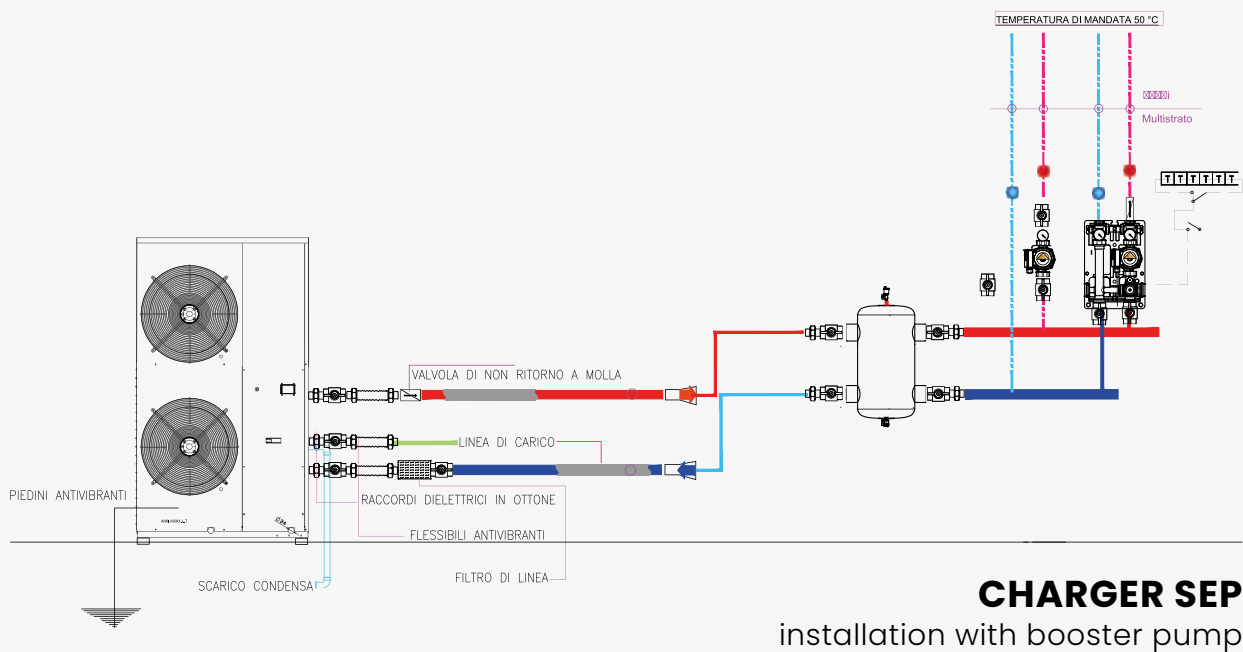
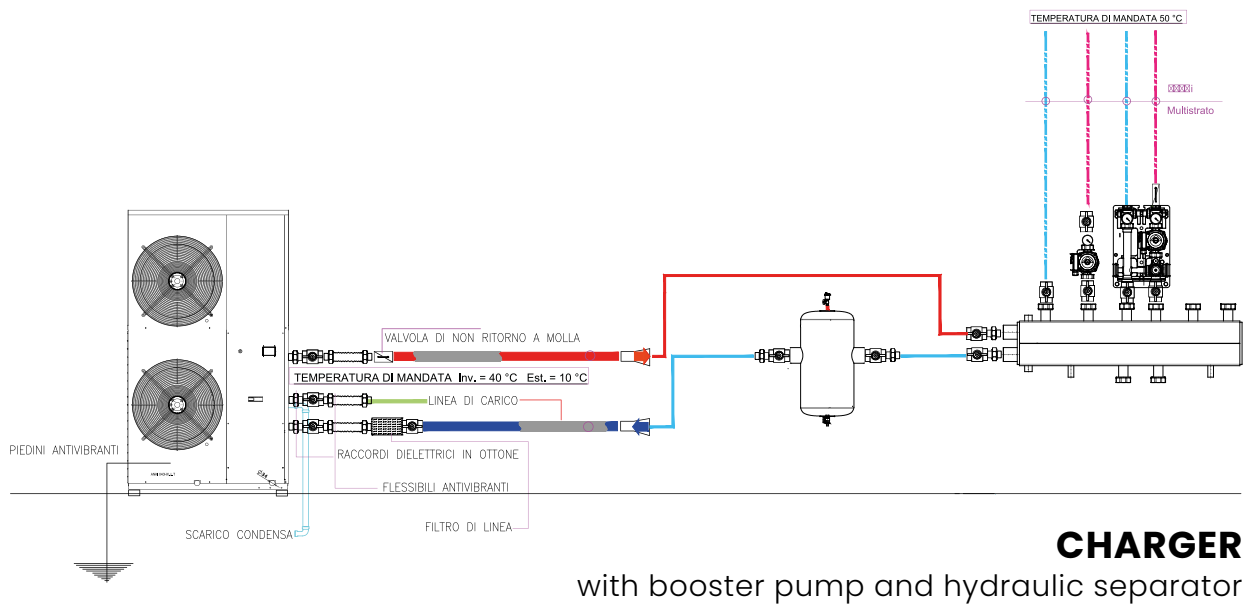
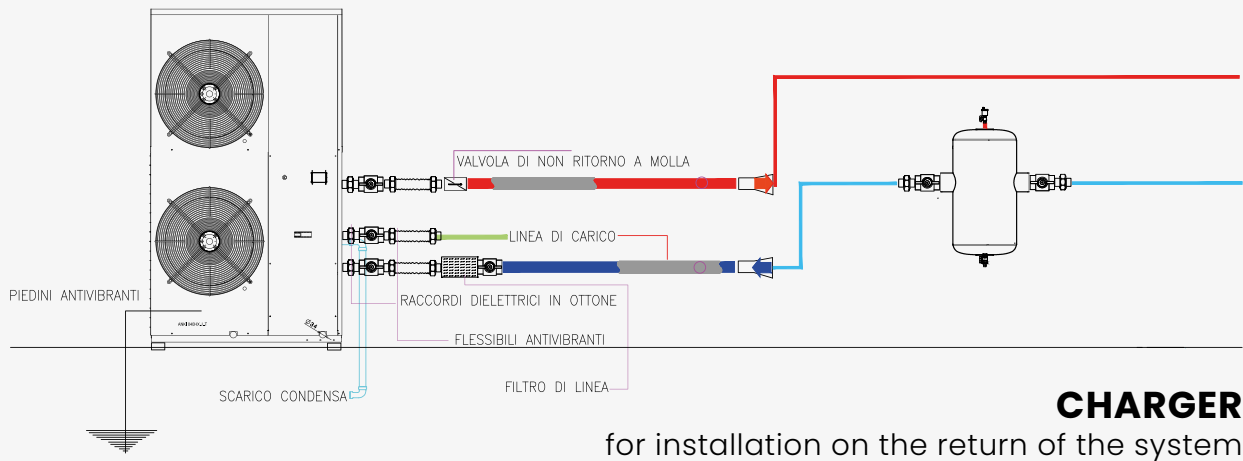

CHARGER

 50 / 80 / 100 *lt*

BUFFER TANK (or inertial storage) for installation on the return of systems in Heat pump, with double function of accumulator and dirt separator.

+ Why to choose it:

CHARGER serves to reduce the number of starts of the implant with a consequent increase of the thermal inertia of the circuit and therefore more stable operating temperatures.

The presence of CHARGER is essential to allow its regular operations, even at low load thermal of the heat pump system.

TECHNICAL DATA

	CHARGER 50	CHARGER 80	CHARGER 100
Capacity (LT)	50	80	100
Max working temperature (C°)	-10	-10	-10
Max working pressure (bar)	6	6	6
Energy Class	C	C	C
Net weight (KG)	17	21	30
Water connections	1 1/4 f	1 1/4 F	1 1/4 F
Connections relief valve	1/2' f	1/2' F	1/2' F
Connections dirt separator	1 1/4 f	1 1/4 F	1 1/4 F

+ MANUFACTURING MATERIAL:
STEEL S 235 JR L)

+ **ABSENCE OF CFC;**
POLYURETHANE FOAM
FOR ECOLOGICAL THERMAL
INSULATION

+ **SUPPLIED WITH DOUBLE**
BRACKET FOR WALL
ATTACHMENT (IN ORDER TO
SAVE SPACE IN THE TECHNICAL
COMPARTMENT)



**ENVIRONMENT
RESPECT**

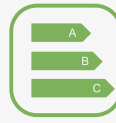

**ERP
2017**



**LOW NOISE
WORKING**



**ROHS
COMPONENT**



**POLYURETHANE
FOAM CFC FREE**

DIMENSIONS

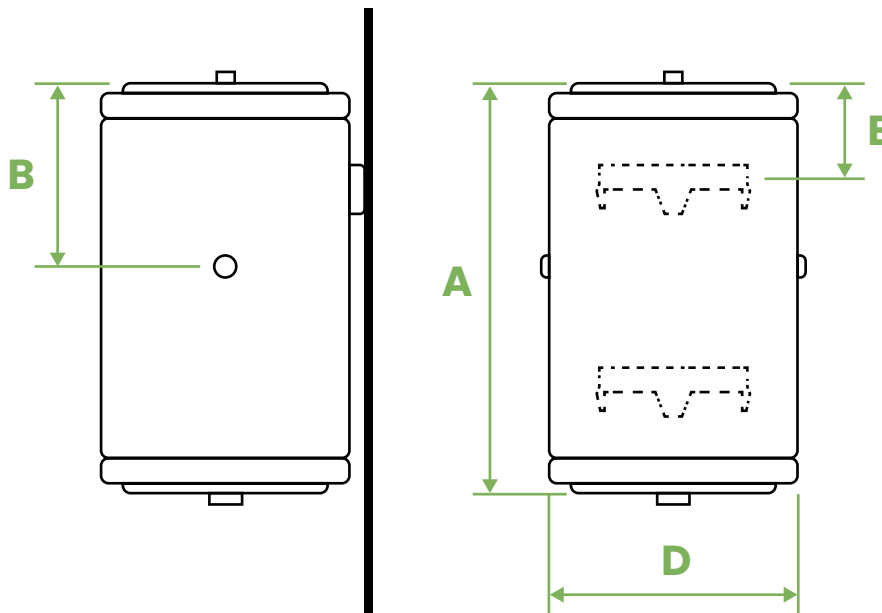

	A	B	D	E
CHARGER 50	600 mm	240 mm	460 mm	180 mm
CHARGER 80	760 mm	240 mm	460 mm	180 mm
CHARGER 100	960 mm	240 mm	460 mm	180 mm

CHARGER SEP



50 / 80 / 100 *lt*

BUFFER TANK (or inertial storage) for installation both on the OUTPUT and on the RETURN of the system, with the function of accumulator and HYDRAULIC SEPARATOR (SEP).

+ Why to choose it:

If they have not already been installed in the system (the separator and the collector) CHARGER SEP brings significant cost savings (e.g. purchase and installation) of the separator, being already present on the product.

CHARGER SEP gives regularity of heat pump operation, It can be easily installed inside the internal part of the household, intercepting both the OUTPUT and the RETURN of the system.

TECHNICAL DATA

	CHARGER SEP 50	CHARGER SEP 80	CHARGER SEP 100
Capacity (LT)	50	80	100
Max working temperature (C°)	-10	-10	-10
Max working pressure (bar)	6	6	6
Energy Class	C	C	C
Net weight (KG)	17	21	30
Water connections	1 1/4 f	1 1/4 F	1 1/4 F
Connections relief valve	1/2' f	1/2' F	1/2' F
Connections dirt separator	1 1/4 f	1 1/4 F	1 1/4 F

+ MANUFACTURING MATERIAL:
STEEL S 235 JR L)

+ **ABSENCE OF CFC;**
POLYURETHANE FOAM
FOR ECOLOGICAL THERMAL
INSULATION

+ **SUPPLIED WITH DOUBLE**
BRACKET FOR WALL
ATTACHMENT (IN ORDER TO
SAVE SPACE IN THE TECHNICAL
COMPARTMENT)

+ **DIRT SEPARATOR** ALREADY
PRESENT IN THE PRODUCT



**ENVIRONMENT
RESPECT**

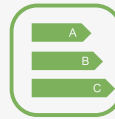

**ERP
2017**



**LOW NOISE
WORKING**



**ROHS
COMPONENT**



**POLYURETHANE
FOAM CFC FREE**

DIMENSIONS

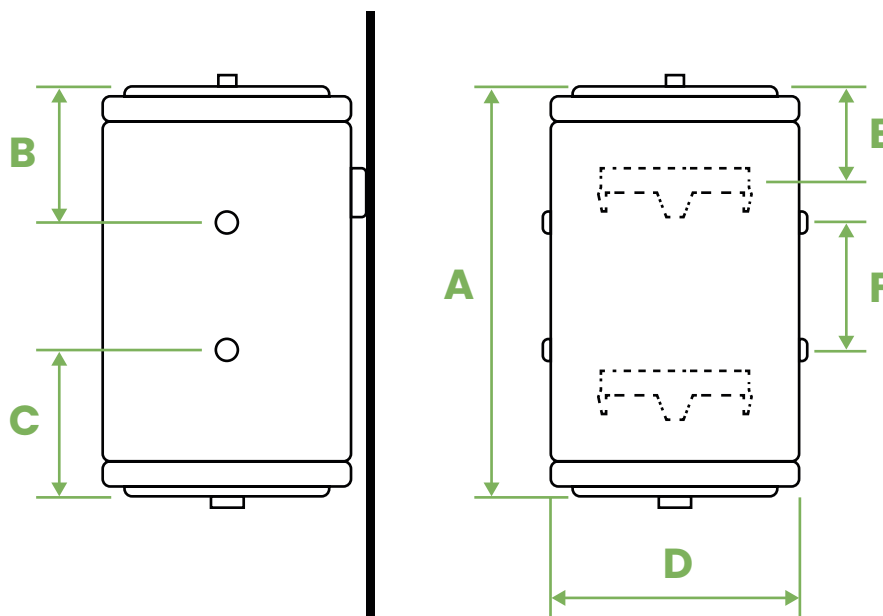

	A	B	C	D	E	F
CHARGER SEP 50	600 mm	240 mm	185 mm	460 mm	180 mm	175 mm
CHARGER SEP 80	760 mm	240 mm	255 mm	460 mm	180 mm	265 mm
CHARGER SEP 100	960 mm	240 mm	360 mm	460 mm	180 mm	350 mm



PACKAGING DIMENSIONS

Model	Peso lordo (Kg)	Dimensione Imballo LxPxH (mm)	Volume (m³)
A5	6	290x400x260	0,030
A12	7	470x390x250	0,046
A15	9	470x400x290	0,055
Q12	8	397x392x296	0,046
Q15	9	420x310x300	0,039
B14	10	710x255x260	0,047
B30	13	590x500x340	0,100
C65	29	310x510x935	0,148
ECO60	22	470x490x720	0,166
ECO80	26	470x490x870	0,200
ECO100	35	470x490x1100	0,253
COXL 60	*	575x575x640	0,212
COXL 80	*	575x575x780	0,258
SMART60	22	470x490x720	0,166
SMART80	26	470x490x870	0,200
SMART100	35	470x490x1100	0,253
SE50	20	470x490x590	0,136
SE80	24	470x490x780	0,180
SE100	27	470x490x900	0,207
SE120	33	470x490x1100	0,253
SE150	41	575x575x1080	0,357
SE200	48	575x575x1235	0,408
SO50	20	470x490x590	0,136
SO80	24	470x490x780	0,180
SO100	27	470x490x900	0,207
SO120	33	470x490x1100	0,253
SO150	41	575x575x1080	0,357
SO200	48	575x575x1235	0,408
ST50	*	470x490x590	0,136
ST80	*	470x490x780	0,180
ST100	*	470x490x900	0,207
ST120	*	470x490x1100	0,253
ST150	*	575x575x1080	0,357
ST200	*	575x575x1235	0,408
STU80	*	470x490x780	0,180
STU100	*	470x490x900	0,207

Model	Peso lordo (Kg)	Dimensione Imballo LxPxH (mm)	Volume (m³)
STX80	*	470x490x780	0,180
STX100	*	470x490x900	0,207
STX120	*	470x490x1100	0,253
STX150	*	575x575x1080	0,357
STX200	*	575x575x1235	0,408
SO/T 80	*	470x490x780	0,180
SO/T 100	*	470x490x900	0,207
SO/T 120	*	470x490x1100	0,253
SO/T 150	*	575x575x1080	0,357
SO/T 200	*	575x575x1235	0,408
SEP150	*	575x575x	0,000
SEP200	*	575x575x	0,000
SEP300	*		0,000
SLIM20	*	410x410x460	0,077
SLIM30	13	410x410x550	0,092
SLIM45 (V/H)	19	410x410x780	0,131
SLIM60 (V/H)	25	410x410x970	0,163
SL80	41	380x380x1450	0,209
SX80	41	380x380x1450	0,209
SZ80	42	380x380x1450	0,209
CHARGER50	*	470x490x700	0,161
CHARGER80	*	470x490x860	0,198
CHARGER100	*	470x490x1100	0,253
CHARGERSEP50	22	470x490x700	0,161
CHARGERSEP80	25	470x490x860	0,198
CHARGERSEP100	30	470x490x1100	0,253





Bandini
WATER HEATERS



Bandini

WATER HEATERS

Bandini Scaldabagni S.p.a.
Via Po, 11 - 53036 Poggibonsi (Siena)
ITALY

www.bandiniwaterheaters.com