

Thermostatic valve bodies

for all thermostatic heads
and actuators

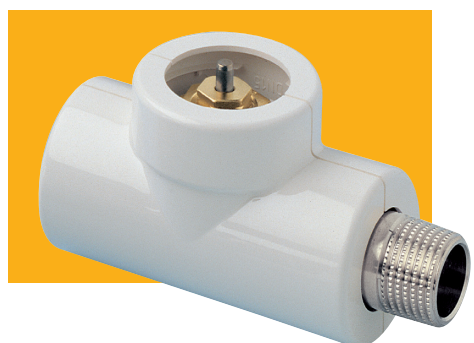

To be precise.

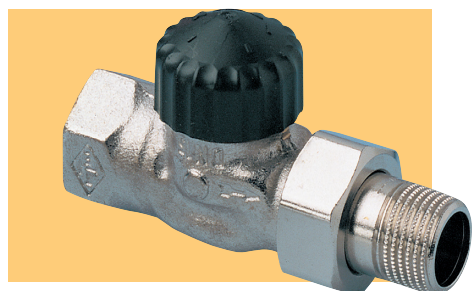
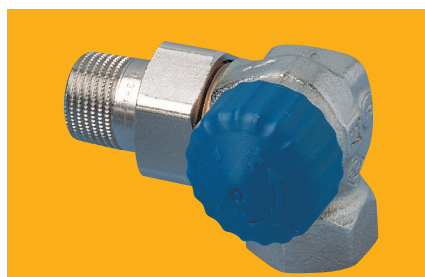
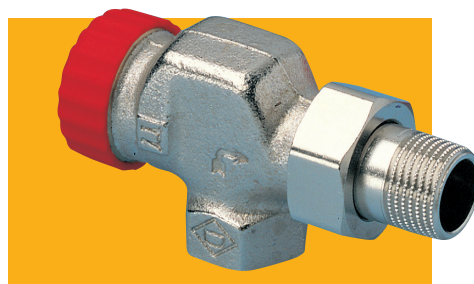

Thermostatic valve bodies

Table of contents

	Page
Thermostatic valve bodies	
Standard	
Description	3
Assembly	3
Application	4
Article numbers	5
V-exakt with precision presetting	
Description	6
Assembly	6
Application	7, 8
Operation	8
Article numbers	9
F-exakt with precision finest presetting	
Description	10
Assembly	10
Application	11, 12
Operation	12
Article numbers	13
With particularly low resistance (gravity)	
Description	14
Assembly	14
Application	15
Article numbers	16
For reversed flow direction	
Description	17
Assembly	17
Application	18
Article numbers	19
Thermostatic three-way valve body with automatic bypass control	
Description	20
Assembly	20
Application	21
Article numbers	22
Accessories	23–26
Thermostatic inserts	27
Technical data / Diagrams	
Standard thermostatic valve body	28, 29
Standard flat sealing thermostatic valve body	30, 31
V-exakt thermostatic valve body	32
F-exakt thermostatic valve body	33
Thermostatic valve body with particularly low resistance	34, 35
Thermostatic three-way valve body	36
k_v -value / k_{vs} -value definition	37
Dimensional data sheet	38, 39
List of KEYMARK-certified thermostatic heads and valve bodies	40

Standard

Description



The Standard HEIMEIER thermostatic valve bodies with black protection caps can be used with all HEIMEIER thermostatic heads and actuators.

The stainless spindle is equipped with a double O-ring sealing. The outer O-ring is replaceable under pressure. With the HEIMEIER fitting tool, the complete thermostatic insert can be replaced with NW 10 to NW 20 without the need to drain off the system.

The body, which is made of corrosion-resistant gunmetal with a female thread, is designed for connection to a threaded pipe, or in conjunction with compression fittings, for connection to copper or precision steel pipes. The model with a male thread, in conjunction with the appropriate compression fittings, makes it possible

to connect a plastic pipe. Versions with Viega press connection (15 mm) with SC-Contur are suitable for copper, Viega Sanpress stainless steel and Prestabo steel pipes.

For the HEIMEIER valve bodies, use only the accompanying, labelled HEIMEIER compression fitting (label e. g. 15 THE).

The NW 10 / NW 15 models with boss marking can be converted to presetting or finest presetting (see page 27).

The NW 10 / NW 15 thermostatic valve bodies in angle and straight form with a female thread and press connection can be fitted with covers from the DESIGN-LINE range (not for valve bodies with reduced length), see accessories.

Assembly

e. g. Thermolux K thermostatic valve

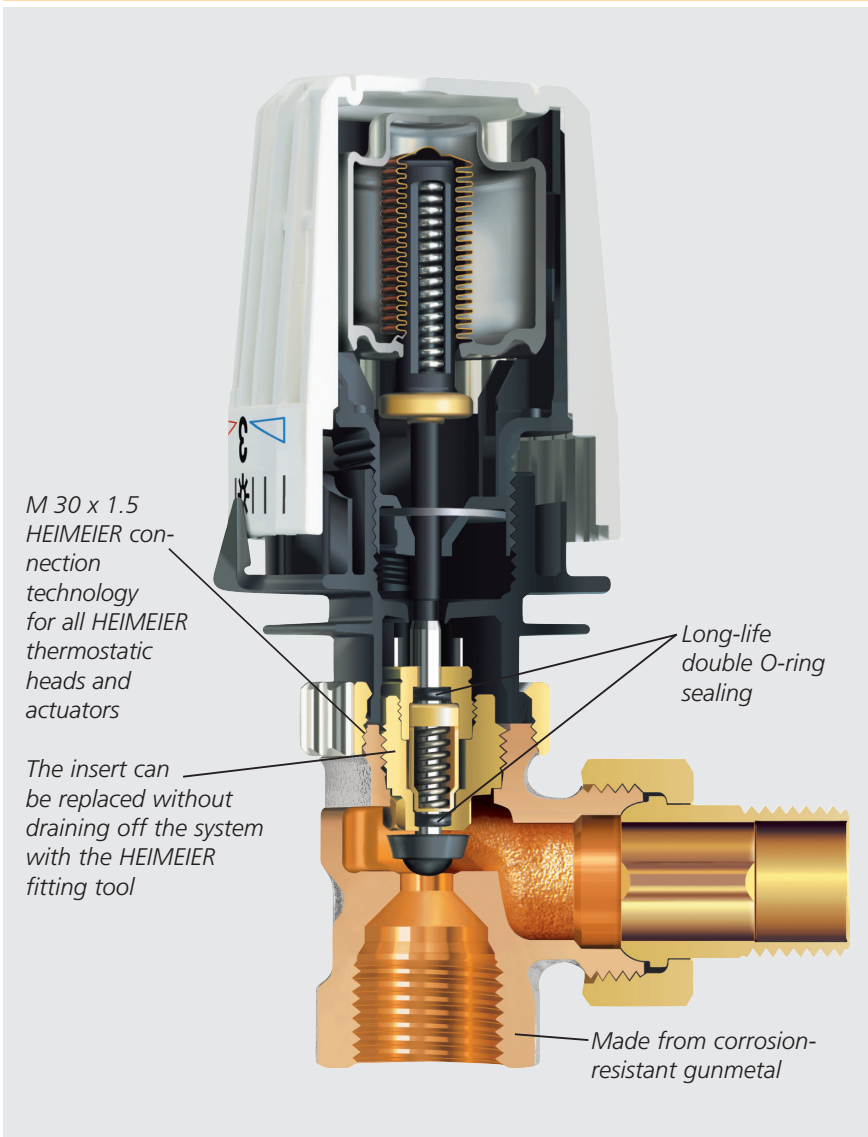

KEYMARK certified and tested according to DIN EN 215, see page 40

- Stainless spindle with double O-ring
- Body made of corrosion-resistant gunmetal
- The thermostatic insert with NW 10 to NW 20 can be replaced under pressure
- Can be fitted with covers from the DESIGN-LINE range
- Also available in Press-Line version with Viega SC-Contur

Thermostatic valve bodies

Standard

Application

The HEIMEIER Standard thermostatic valve bodies are used in two-pipe pump heating systems with normal temperature spread.

Corresponding to the standards EnEV and DIN V 4701-10, the valve bodies can be designed with a control difference from 1 K to 2 K thus enabling a broad flow spectrum (for technical

data/diagrams, see pages 28 to 31).

Kvs diaphragms make the reduction or restriction of the mass flow possible (for technical data/diagrams, see pages 28, 29).

A hydraulic balance, which is an additional requirement, can be reached with the appropriate lockshields e. g. HEIMEIER Regulux.

To ensure low-noise operation, experience has shown that the differential pressure over the thermostatic valves should not exceed approx. 0.2 bar. If when planning a system it is clear that high differential pressures occur in the partial load area, differential pressure regulating devices, e. g. the TA STAP differential pressure controller or the Hydrolux overflow valve should be used.

Sample application

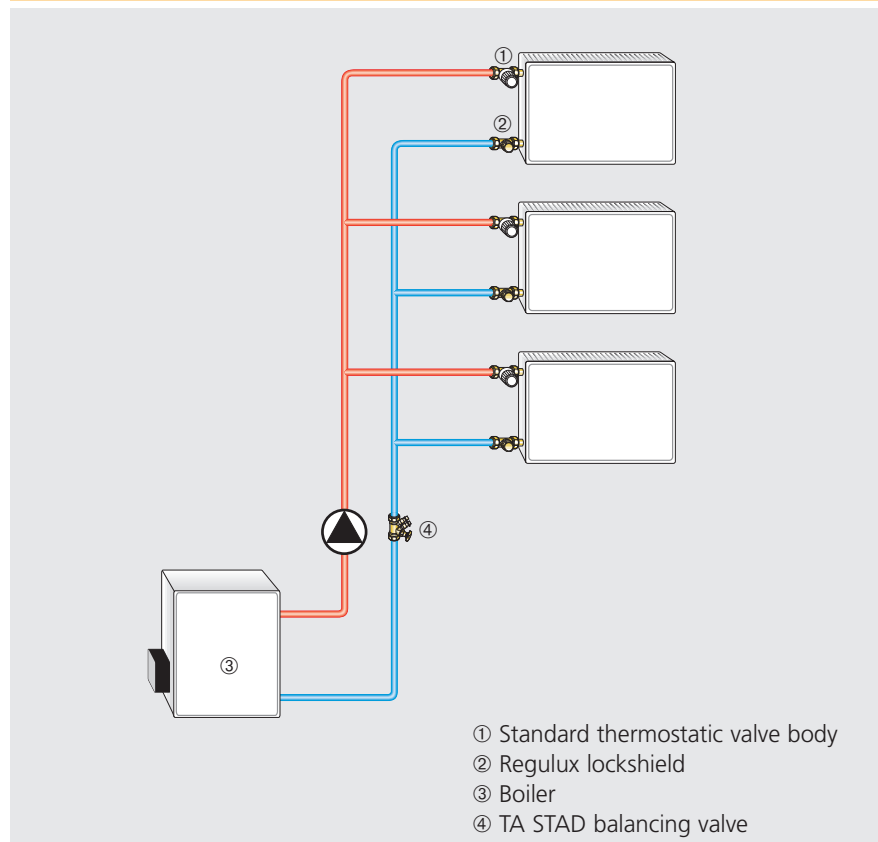

Notes

– To avoid damage and the formation of scale deposit in the hot water heating system, the composition of the heat transfer medium should be in accordance with the VDI guideline 2035.

For industrial and long-distance energy systems, see the applicable codes VdTÜV and 1466/AGFW FW 510. A heat transfer medium containing mineral oils, or any type of lubricant containing mineral oil can have extremely negative effects on the source apparatus and usually lead to the disintegration of EPDM seals. When using nitrite-free frost and corrosion resistance solutions with an ethylene glycol base, pay close attention to the details outlined in the manufacturers' documentation, particularly concerning concentration and specific additives.

– The thermostatic valve bodies can be used with all HEIMEIER thermostatic heads and thermal or motorized actuators. The optimal tuning of the components guarantees maximum safety.

When using actuators from other manufacturers, make sure that the pressure power is appropriate for thermostatic valve bodies with soft sealing valve discs.

Press-Line Connection with Viega SC-Contur

Standard thermostatic valve bodies with 15 mm Viega press connection are suitable for copper pipes conforming to EN 1057 as well as Viega Sanpress stainless steel and Prestabo steel pipes.

All press connections as well as the valve bodies are made of corrosion-resistant, dezincification-free gunmetal.

Since this a Viega press connection, all suitable Viega press-fitting jaws can be used. This means there is no need to purchase costly press-fitting tools and jaws.

The pressing action is produced by a formed hexagon recess before and after the beading of the connector and gives the press-fitted joint the necessary strength. In addition, the press-fitting beading is specifically formed such as to give the high-

grade EPDM sealing element its defined shape.

In the interest of safety, the press connections are equipped with SC-Contur (SC = safety connection) which makes it possible to detect non-pressed joints by visible leaks when filling the system. During the press-fitting operation, the SC-Contur is practically reformed and loses its effect in the process, thus producing a permanent, tight and positive joint connection. Initially, press-fitting joints that do not feature SC-Contur can appear to be tight in the non-pressed state, however, they can slide apart during subsequent operation of the system.

The hexagon on the valve bodies is a particularly practical feature for holding the fit-

tings while tightening the union nut.

The following press-fitting tools can be used, e.g.

- Viega: Type 2, PT3-H, PT3-EH, PT3-AH, battery-powered Presshandy, Pressgun 4E/4B

- Geberit: PWH 75

- Geberit /Novopress: Type N 230V, Type N battery-powered

- Mapress/Novopress: EFP 2, ACO 1/ ECO 1











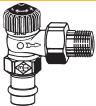

- Klauke: UAP 2

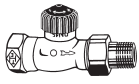
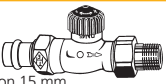
The suitability of other press-fitting tools should be verified with the respective manufacturer.

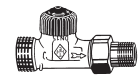
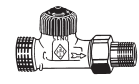
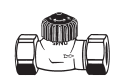
We recommend using only Viega press-fitting jaws to make Viega press connections.

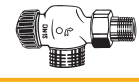
Standard

Article numbers

Structure	NW	kv-value [m³/h] p-band [K]			kv _s - value [m³/h]	Gunmetal nickel-plated Art. no.
		1.0	2.0	3.0		
Angle 	ET 10 (3/8") ET 15 (1/2") ET 20 (3/4") ET 25 (1") ET 32 (1 1/4")	0.25 0.25 0.40 0.70 0.80	0.49 0.49 0.79 1.35 1.60	0.66 0.66 1.26 1.90 2.35	1.25 1.35 2.50 5.70 6.70	2201-01.000 2201-02.000 2201-03.000 2201-04.000 2201-05.000
Angle with Viega press connection 15 mm 	ET 15 (1/2")	0.25	0.49	0.66	1.35	2291-15.000 
Angle with reduced lengths 	ET 10 (3/8") ET 15 (1/2") ET 20 (3/4")	0.25 0.25 0.40	0.49 0.49 0.79	0.66 0.66 1.26	1.25 1.35 2.50	2215-01.000 2215-02.000 2215-03.000
Angle with male thread G 3/4 	ET 15 (1/2")	0.25	0.49	0.66	1.35	9175-02.000
Straight 	DT 10 (3/8") DT 15 (1/2") DT 20 (3/4") DT 25 (1") DT 32 (1 1/4")	0.25 0.25 0.40 0.70 0.80	0.49 0.49 0.79 1.35 1.60	0.66 0.66 1.26 1.90 2.35	1.25 1.35 2.50 5.70 6.70	2202-01.000 2202-02.000 2202-03.000 2202-04.000 2202-05.000
Straight with Viega press connection 15 mm 	DT 15 (1/2")	0.25	0.49	0.66	1.35	2292-15.000 
Straight with reduced lengths 	DT 10 (3/8") DT 15 (1/2") DT 20 (3/4")	0.25 0.25 0.40	0.49 0.49 0.79	0.66 0.66 1.26	1.25 1.35 2.50	2216-01.000 2216-02.000 2216-03.000
Straight with male thread G 3/4 	DT 15 (1/2")*)	0.38	0.79	1.10	1.70	1344-02.000
Straight flat sealing 	DT 15 (1/2") DT 15 (1/2") DT 15 (1/2") DT 20 (3/4")	0.25 0.38 0.46 0.40	0.49 0.73 0.92 0.79	0.66 1.10 1.23 1.26	1.35 1.70 2.50 2.50	2272-02.000 2274-02.000 2276-02.000 (Blue cap) 2272-03.000
Straight with bended nipple 	DT 15 (1/2")	0.25	0.49	0.66	1.35	2206-02.000
Axial 	AT 10 (3/8") AT 15 (1/2")	0.25 0.25	0.49 0.49	0.66 0.66	1.25 1.35	2225-01.000 2225-02.000
Axial with male thread G 3/4 	AT 15 (1/2")	0.25	0.49	0.66	1.35	2235-02.000
Double angle Connection to radiator left 	WET 10 (3/8") WET 15 (1/2")	0.25 0.25	0.49 0.49	0.66 0.66	1.10 1.15	2311-01.000 2311-02.000
Double angle with male thread G 3/4 Connection to radiator left 	WET 15 (1/2")	0.25	0.49	0.66	1.15	2313-02.000
Double angle Connection to the radiator right 	WET 10 (3/8") WET 15 (1/2")	0.25 0.25	0.49 0.49	0.66 0.66	1.10 1.15	2310-01.000 2310-02.000
Double angle with male thread G 3/4 Connection to the radiator right 	WET 15 (1/2")	0.25	0.49	0.66	1.15	2312-02.000

Permitted operating temperature TB 120°C (248°F), with cover, TB 90°C (194°F), with press connection TB 110°C (230°F). Permitted operating pressure PB 10 bar, low pressure steam 110°C (230°F) / 0.5 bar. Compression fittings, see accessories. *) Technical data: Brochure "Control valves for floor heating systems".

Thermostatic valve bodies

V-exakt

Description



The HEIMEIER V-exakt thermostatic valve bodies with integrated precision presetting and white protection cap can be used with all HEIMEIER thermostatic heads and actuators.

The flow ranges of the presetting can be easily and precisely set with a key. The selected value can be read on the front of the thermostatic insert. With the key, only a specialist can create or change the setting. It is impossible for a non-specialist to tamper with the settings without a tool.

The stainless spindle is equipped with a double O-ring sealing. The outer O-ring is replaceable under pressure.

The complete thermostatic insert can be replaced with the HEIMEIER fitting tool without draining off the system.

The body, which is made of corrosion-resistant gunmetal with a female thread,

is designed for connection to a threaded pipe, or in conjunction with compression fittings, for connection to copper or precision steel pipes. The model with a male thread, in conjunction with the appropriate compression fittings, makes it possible to connect a plastic pipe. Versions with Viega press connection (15 mm) with SC-Contur are suitable for copper, Viega Sanpress stainless steel and Prestabo steel pipes.

For HEIMEIER valve bodies, use only the accompanying, labelled HEIMEIER compression fitting (label e. g. 15 THE).

The NW 10 / NW 15 thermostatic valve bodies in angle and straight form with a female thread and press connection can be fitted with covers from the DESIGN-LINE range (not for valve bodies with reduced length) – see accessories.

Assembly

V-exakt

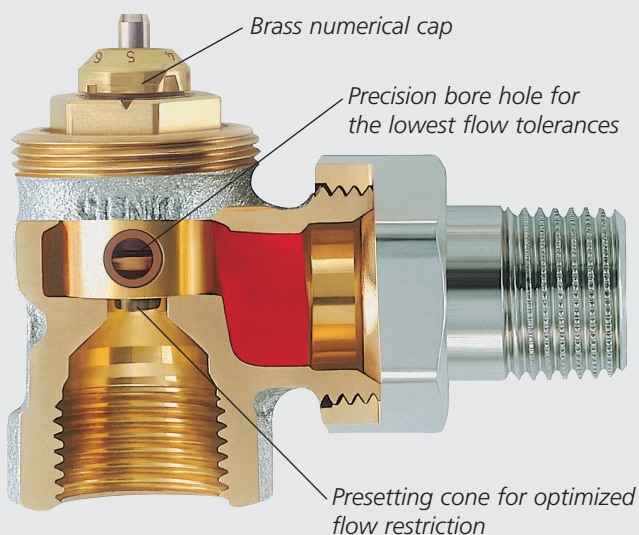

KEYMARK certified and tested according to DIN EN 215, see page 40

- Presetting with one twist
- The setting can be controlled
- Secured against misuse by a key
- Lowest flow tolerances
- Optimized flow restriction
- Can be fitted with covers from the DESIGN-LINE range
- Also available in Press-Line version with Viega SC-Contur



V-exakt conforms to the requirements of the "highly expanded version" and the "standard version" of the specification FW 507 drawn up by the Arbeitsgemeinschaft Fernwärme (AGFW) (Working Group for District Heating).

V-exakt

Application

HEIMEIER V-exakt thermostatic valve bodies are used in two-pipe warm water pump heating systems with normal to high temperature spread.

The integrated precision presetting makes precise hydraulic balancing possible with the aim of providing all heat consumers with hot water according to their heat requirements. A prerequisite for this is that the set values are actually reached in practise. For this to happen, it is absolutely necessary that flow tolerances are maintained. It is possible to meet this requirement thanks to 6 different large precision bore holes, only one of which is opened for the appropriate flow

range at any time, depending on the setting.

However, a regular distribution of water should not only be achieved while the system is operating according to the design, but also after a drop in room temperature or during intermissions in operation, particularly for large systems, in order to avoid under- or oversupply to parts of the system. In order to achieve this, the valve is fitted with a specially developed presetting cone to restrict the flow. This ensures that even when it is preset to 6, and the valve is fully open, the radiator mass flow will not exceed the approx. 1.5 part rate.

Corresponding to the standards EnEV and DIN V 4701-10, V-exakt thermostatic valve bodies can be designed with a control difference of up to max. 1 K or max. 2 K (for technical data/diagrams, see page 32).

To ensure low-noise operation, experience shows that the differential pressure over the thermostatic valves should not exceed approx. 0.2 bar. If when planning a system, it is clear that high differential pressures occur in the partial load area, differential pressure regulating devices, e.g. the TA STAP differential pressure controller or the Hydrolux overflow valve should be used.

Lowest flow tolerances

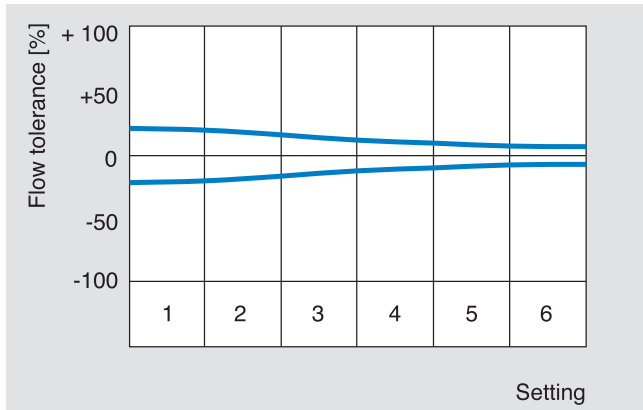

Optimized flow restriction

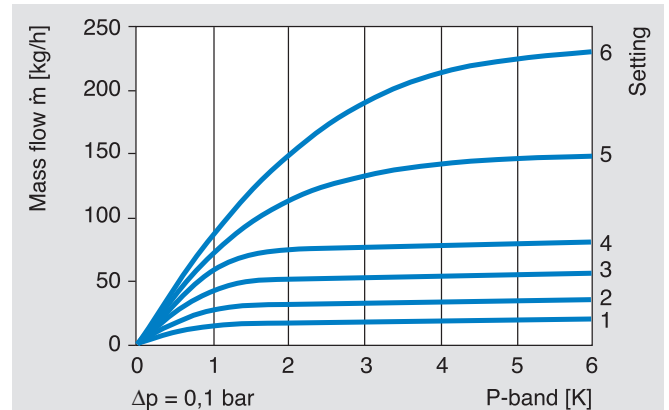

Sample application

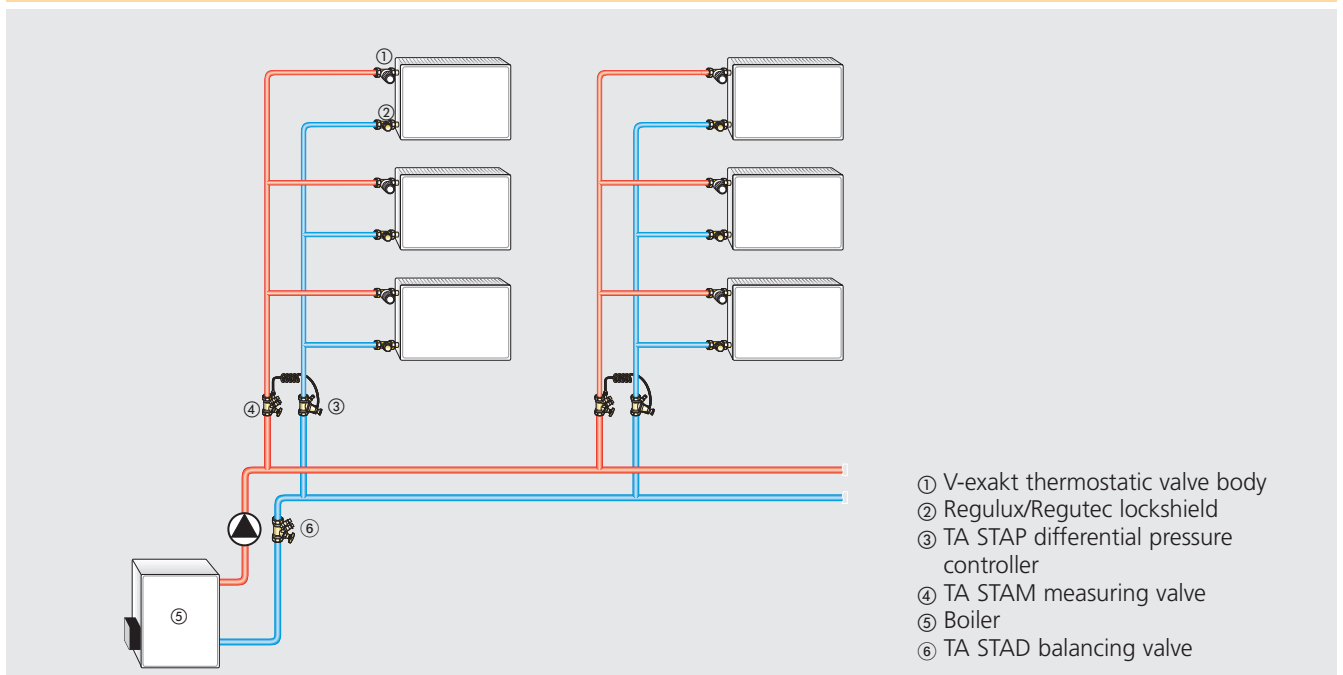

Thermostatic valve bodies

V-exakt

Notes

– The composition of the heat transfer medium should be one which avoids damage or the accumulation of stones in hot water heating systems, in accordance with VDI guide line 2035. For industrial and long-distance energy systems, see the applicable codes VdTÜV and 1466/AGFW FW 510. A heat transfer medium containing mineral oils, or any type of lubricant containing mineral oil

can have extremely negative effects on the source apparatus and usually leads to the disintegration of EPDM seals.

When using nitrite-free frost and corrosion resistance solutions with an ethylene glycol base, pay close attention to the details outlined in the manufacturers' documentation, particularly concerning concentration and specific additives.

– The thermostatic valve bodies can be used with all HEIMEIER thermostatic heads and thermal or motorized actuators. Tune components appropriately to guarantee maximum safety.

When using actuators from other manufacturers, make sure that the pressure power is appropriate for thermostatic valve bodies with soft sealing valve discs.

Press-Line Connection with Viega SC-Contur

V-exakt thermostatic valve bodies with 15 mm Viega press connection are suitable for copper pipes conforming to EN 1057 as well as Viega Sanpress stainless steel and Prestabo steel pipes.

All press connections as well as the valve bodies are made of corrosion-resistant, dezincification-free gunmetal.

Since this is a Viega press connection, all suitable Viega press-fitting jaws can be used. This means there is no need to purchase costly press-fitting tools and jaws.

The pressing action is produced by a formed hexagon recess before and after the beading of the connector and gives the press-fitted joint the necessary strength. In addition, the press-fitting beading is specifically formed such as to give the high-grade

EPDM sealing element its defined shape.

In the interest of safety, the press connections are equipped with SC-Contur (SC = safety connection) which makes it possible to detect non-pressed joints by visible leaks when filling the system. During the press-fitting operation, the SC-Contur is practically reformed and loses its effect in the process, thus producing a permanent, tight and positive joint connection. Initially, press-fitting joints that do not feature SC-Contur can appear to be tight in the non-pressed state, however, they can slide apart during subsequent operation of the system.

The hexagon on the valve bodies is a particularly practical feature for holding the fittings while tightening the union nut.

The following press-fitting tools can be used, e.g.

- Viega: Type 2, PT3-H, PT3-EH, PT3-AH, battery-powered Presshandy, Pressgun 4E/4B
- Geberit: PWH 75
- Geberit /Novopress: Type N 230V, Type N battery-powered
- Mapress/Novopress: EFP 2, ACO 1/ ECO 1
- Klauke: UAP 2

The suitability of other press-fitting tools should be verified with the respective manufacturer.

We recommend using only Viega press-fitting jaws to make Viega press connections.

Operation

Presetting

The valve body has over 6 flow areas which are adjacent to each other without gaps (see fig.). Due to the p-band variation, each area ensures a smooth adaptation or restriction of the radiator mass flow to the heating installation. In this way, the valve can smoothly realize each flow between the smallest

and largest value despite precisely defined settings (see fig.).

The presetting can be set at between 1, 2, 3, 4, 5 and 6. The setting 6 corresponds to the normal setting (manufacturer's setting). To set the presetting, the key (Art. no. 3501-02.142) is used

on the valve insert and the required value is set. Then the key is removed.

The set value can be read on the front of the valve insert, i.e. from the control side (see fig.). Without a tool, it is impossible for a non-qualified person to tamper with the presetting.

Gap-free flow ranges

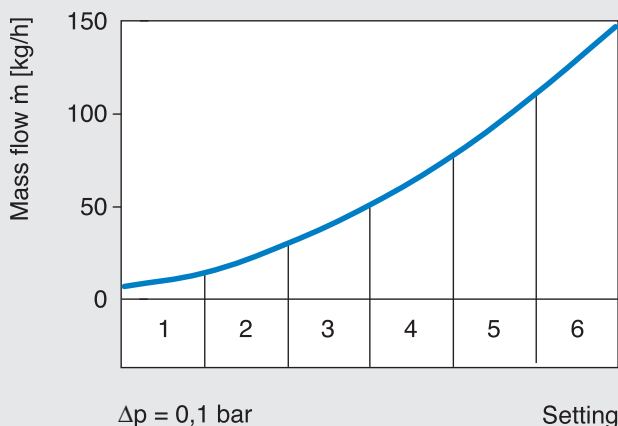





Can be read from the front

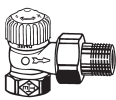
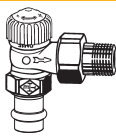

V-exakt

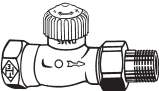
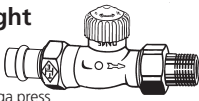
Article numbers

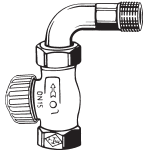
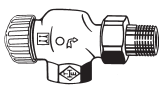
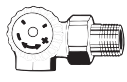
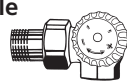
Structure	NW	kv-value [m ³ /h] with p-band max. 2 K		kvs-value (preset. 6) [m ³ /h]	Gunmetal nickel-plated Art. no.
		presetting 1 [min]	6 [max]		
Angle 	ET 10 (3/8")	0.025	0.468	0.73	3511-01.000 3511-02.000 3511-03.000
	ET 15 (1/2")	0.025	0.468	0.73	
	ET 20 (3/4")	0.025	0.468	0.73	
Angle  with Viega press connection 15 mm	ET 15 (1/2")	0.025	0.468	0.73	3517-15.000 
Angle with reduced lengths	ET 10 (3/8")	0.025	0.468	0.73	3515-01.000 3515-02.000
	ET 15 (1/2")	0.025	0.468	0.73	
Straight 	DT 10 (3/8")	0.025	0.468	0.73	3512-01.000 3512-02.000 3512-03.000
	DT 15 (1/2")	0.025	0.468	0.73	
	DT 20 (3/4")	0.025	0.468	0.73	
Straight  with Viega press connection 15 mm	DT 15 (1/2")	0.025	0.468	0.73	3518-15.000 
Straight with reduced lengths	DT 10 (3/8")	0.025	0.468	0.73	3516-01.000 3516-02.000
	DT 15 (1/2")	0.025	0.468	0.73	
Straight  with bended nipple	DT 15 (1/2")	0.025	0.468	0.73	3556-02.000
Axial 	AT 10 (3/8")	0.025	0.468	0.73	3510-01.000 3510-02.000
	AT 15 (1/2")	0.025	0.468	0.73	
Axial with male thread G 3/4	AT 15 (1/2")	0.025	0.468	0.73	3530-02.000
Double angle  Connection to radiator left	WET 10 (3/8")	0.025	0.468	0.73	3513-01.000 3513-02.000
	WET 15 (1/2")	0.025	0.468	0.73	
Double angle with male thread G 3/4 Connection to radiator left	WET 15 (1/2")	0.025	0.468	0.73	3533-02.000
Double angle  Connection to radiator right	WET 10 (3/8")	0.025	0.468	0.73	3514-01.000 3514-02.000
	WET 15 (1/2")	0.025	0.468	0.73	
Double angle with male thread G 3/4 Connection to radiator right	WET 15 (1/2")	0.025	0.468	0.73	3534-02.000

Permitted operating temperature TB 120°C (248°F), with cover, TB 90°C (194°F), with press connection TB 110 °C (230°F).
 Permitted operating pressure PB 10 bar. Compression fittings, see accessories.

Thermostatic valve bodies

F-exakt

Description

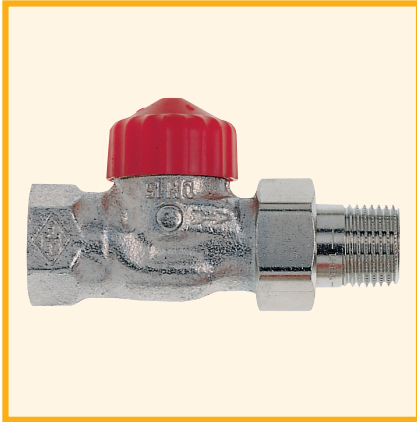

The HEIMEIER F-exakt thermostatic valve bodies with integrated finest presetting and red protection cap can be used with all HEIMEIER thermostatic heads and actuators.

The flow ranges of the presetting can be set easily and precisely using a key. The selected value can be read on the front of the thermostatic insert. With the key, only a specialist can create or change the setting. It is not possible for an unqualified person to tamper with the settings without a tool.

The stainless spindle is equipped with a double O-ring sealing. The outer O-ring is replaceable under pressure. The complete thermostatic insert can

be replaced with the HEIMEIER fitting tool without draining off the system.

The body, which is made of corrosion-resistant gunmetal with a female thread, is designed for connection to a threaded pipe, or in conjunction with compression fittings for connection to copper or precision steel pipes.

For HEIMEIER single-pipe valve bodies, use only the accompanying, labelled HEIMEIER compression fitting (label e. g. 15 THE).

The thermostatic valve bodies in angle and straight form can be fitted with covers from the DESIGN-LINE range – see accessories.

Assembly

F-exakt

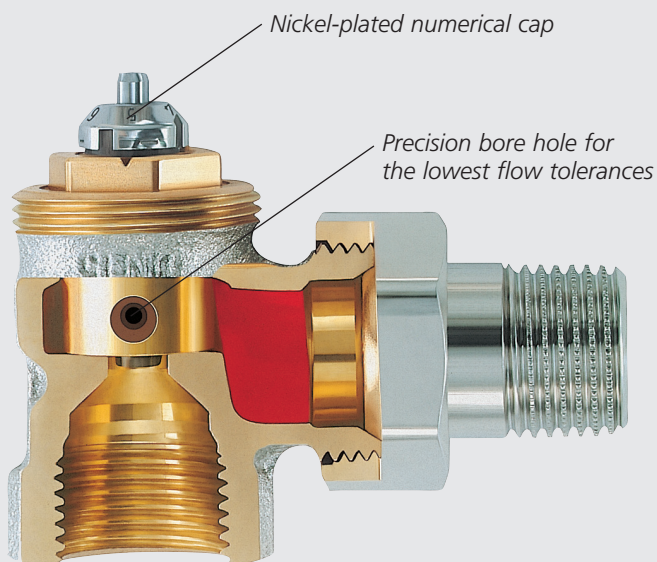

KEYMARK certified and tested according to DIN EN 215, see page 40

- **Finest presetting in one twist**
- **The setting can be checked**
- **Secured against misuse by a key**
- **Lowest flow tolerances**
- **Optimized flow restriction**
- **Can be fitted with covers from the DESIGN-LINE range**



F-exakt conforms to the requirements of the "highly expanded version" and the "standard version" of the specification FW 507 drawn up by the Arbeitsgemeinschaft Fernwärme (AGFW) (Working Group for District Heating).

F-exakt

Application

HEIMEIER F-exakt thermostatic valve bodies are used in two-pipe pump warm water heating systems with low mass flows.

The integrated finest setting makes a precise hydraulic balance possible, with the aim of supplying all heat consumers with hot water according to their heating requirements. This implies that the values which have been calculated or set must also be reached in practise. For this to happen, it is absolutely necessary that flow tolerances are maintained. This accuracy is achieved by six precision bore holes which are co-ordinated with each other, only one of which is released for the appropriate flow range

However, a regular distribution of water should not only be achieved while the system is operating according to the design, but also after a drop in room temperature or during intermissions in operation, particularly for large systems. The flow restricting valve characteristics outside the design body prevent an under- or oversupply to the system. Excessive mass flows are also avoided when the valve is fully open. At the latest, the flow reaches its highest value at approx. 3 K p-band. This is significant above all in e. g. systems which are district heated in order to better maintain return temperatures or adjustments.

Corresponding to the standards EnEV and DIN V 4701-10, F-exakt thermostatic valve bodies can be designed with a control difference of up to max. 1 K or max. 2 K (for technical data/diagrams, see page 33).

To ensure low-noise operation, experience has shown that the differential pressure over the thermostatic valves should not exceed a value of approx. 0.2 bar. If when planning a system it is clear that high differential pressures occur in the partial load area, differential pressure regulating devices, e. g. the TA STAP differential pressure controller or the Hydrolux overflow valve should be used.

Lowest flow tolerances

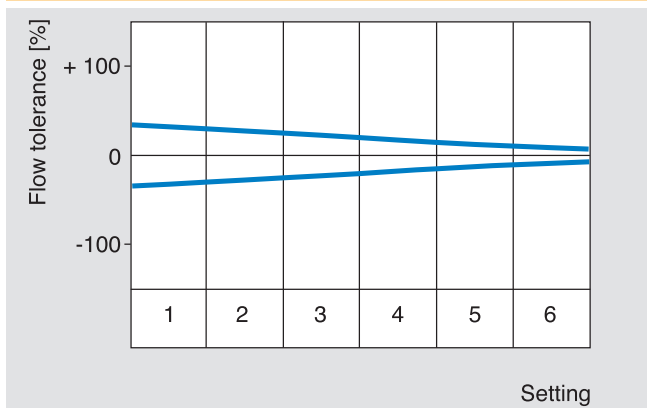

Optimized flow restriction

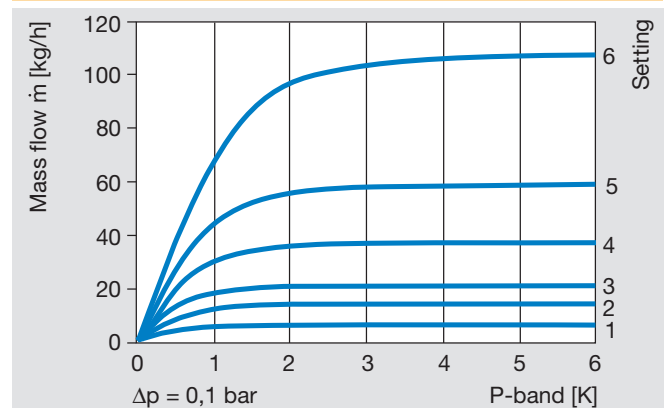

Sample application

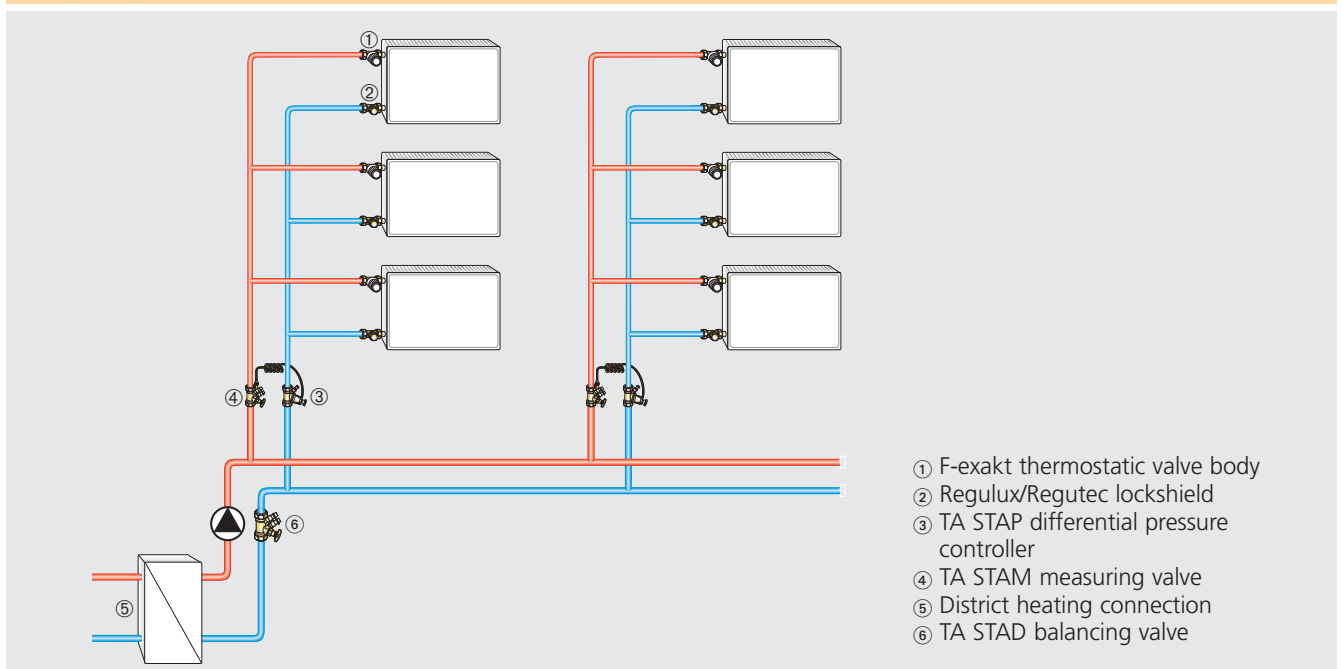

Thermostatic valve bodies

F-exakt

Notes

– To avoid damage and the formation of scale deposit in the hot water heating system, the composition of the heat transfer medium should be in accordance with the VDI guideline 2035.

For industrial and long-distance energy systems, see the applicable codes VdTÜV and 1466/AGFW FW 510. A heat transfer medium containing mineral oils, or any type of lubricant containing mineral oil can have extremely negative effects on the source apparatus and usually lead to the disintegration of EPDM seals.

When using nitrite-free frost and corrosion resistance solutions with an ethylene glycol base, pay close attention to the details outlined in the manufacturers' documentation, particularly concerning concentration and specific additives.

– The thermostatic valve bodies can be used with all HEIMEIER thermostatic heads and thermal or motorized actuators. Tune components appropriately to guarantee maximum safety.

When using actuators from other manufacturers, make sure that the pressure power is appropriate for thermostatic valve bodies with soft sealing valve discs.

Operation

Presetting

The valve body has over 6 flow areas which are adjacent to each other without gaps (see fig.). Due to the p-band variation, each area ensures a smooth adaptation or restriction of the radiator mass flow to the heating installation.

In this way, the valve can realize every flow between the smallest and the largest value without setting the interim-values (see fig.).

The presetting can be set at between 1, 2, 3, 4, 5 and 6. The setting 6 corresponds to the normal setting (manufacturer's setting). To set the presetting, the key (Art. no. 3501-02.142) is used on the valve insert and the required value is set. Then the key is removed.

The set value can be read on the front of the valve insert, i. e. from the control side (see fig.). Without a tool, it is impossible for a non-qualified person to tamper with the presetting.

Gap-free flow ranges

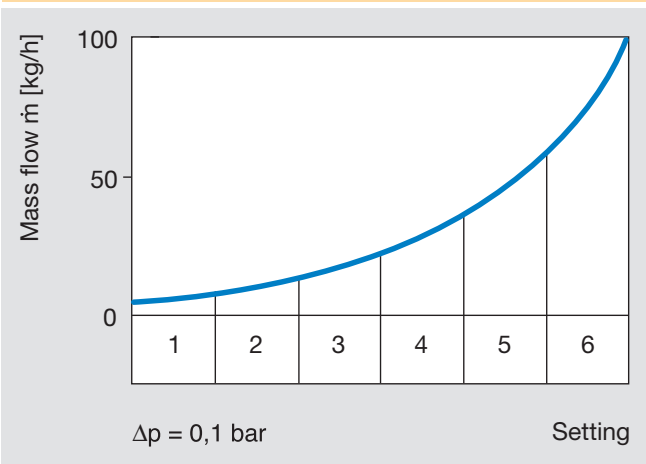

Can be read from the front



F-exakt

Article numbers

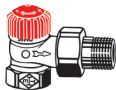
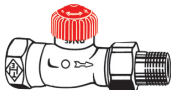
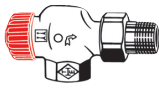
Structure	NW	k _v -value [m ³ /h] with p-band max. 2 K		k _{vs} -value (preset. 6) [m ³ /h]	Gunmetal nickel-plated Art. no.
		1 [min]	6 [max]		
Angle 	ET 10 (3/8")	0.013	0.316	0.35	3431-01.000
	ET 15 (1/2")	0.013	0.316	0.35	3431-02.000
Straight 	DT 10 (3/8")	0.013	0.316	0.35	3432-01.000
	DT 15 (1/2")	0.013	0.316	0.35	3432-02.000
Axial 	AT 10 (3/8")	0.013	0.316	0.35	3430-01.000
	AT 15 (1/2")	0.013	0.316	0.35	3430-02.000

Permitted operating temperature TB 120°C (248°F), with cover, TB 90°C (194°F). Permitted operating pressure PB 10 bar. Compression fittings – see accessories.

Thermostatic valve bodies with particularly low resistance

Description



HEIMEIER thermostatic valve bodies with particularly low resistance (gravity) and blue protection cap can be used with all HEIMEIER thermostatic heads and actuators.

The stainless spindle is equipped with a double O-ring sealing. The outer O-ring is replaceable under pressure. With the HEIMEIER fitting tool, the complete thermostatic insert can be replaced with NW 10 to NW 15 without the need to drain off the system.

The body, which is made of corrosion-resistant gunmetal with a female thread, is designed for connection to a threaded pipe, or in conjunction with compression

fittings, for connection to copper or precision steel pipes.

The model with a male thread, along with the compression fittings, makes it possible to also connect plastic pipes.

For HEIMEIER valve bodies, use only the accompanying, labelled HEIMEIER compression fitting (label e. g. 15 THE).

The thermostatic valve bodies NW 10/ NW 15 in angle and straight form with female thread can be fitted with covers from the DESIGN-LINE range – see accessories.

Assembly

Thermostatic valve body with particularly low resistance (gravity)

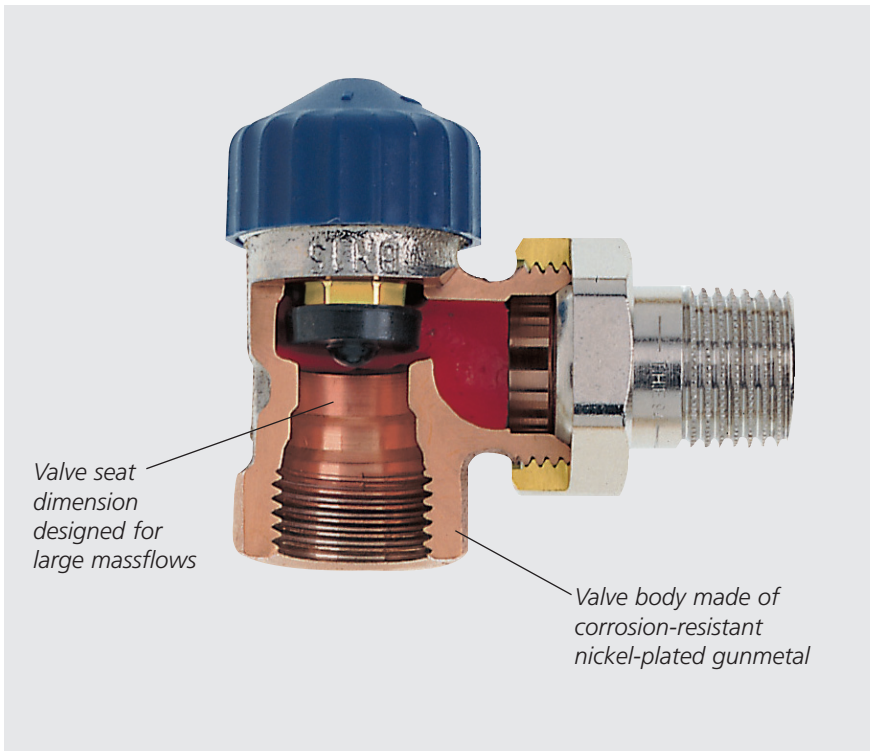

KEYMARK certified and tested according to DIN EN 215, see page 40

- Stainless spindle with double O-ring sealing
- Body made of corrosion-resistant gunmetal
- The thermostatic insert with NW 10 and NW 15 can be replaced under pressure
- Can be fitted with covers from the DESIGN-LINE range

Thermostatic valve bodies with particularly low resistance

Application

The HEIMEIER thermostatic valve bodies with particularly low resistance are used e. g. in two-pipe low temperature heating systems with a small temperature spread and conventional single pipe heating systems.

Corresponding to the standards EnEV and DIN V 4701-10, the valve bodies can be designed with a control difference from 1 K to 2 K thus enabling a broad flow spectrum (for technical data/diagrams, see pages 34, 35).

A hydraulic balance, which is an additional requirement for two-pipe heating systems, can be reached with the appropriate lockshields, e. g. HEIMEIER Regulux.

To ensure low-noise operation, experience shows that the differential pressure over the thermostatic valves should not exceed approx. 0.2 bar. If when planning a system it is clear that high differential pressures occur in the

partial load area, differential pressure regulating devices, e. g. the TA STAP differential pressure controller or the Hydrolux overflow valve should be used.

Sample application

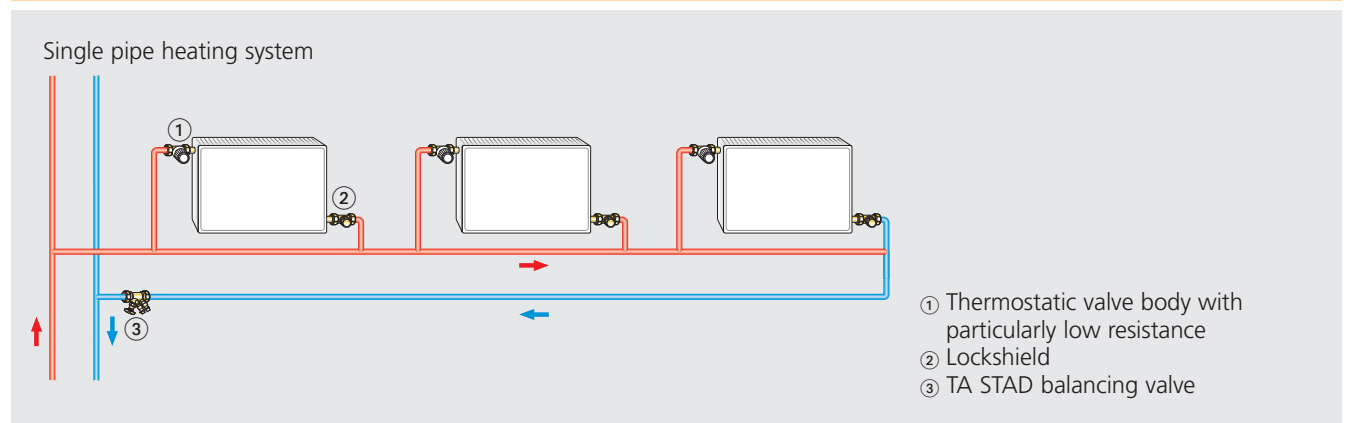

Notes

– To avoid damage and the formation of scale deposit in the hot water heating system, the composition of the heat transfer medium should be in accordance with the VDI guideline 2035. For industrial and long-distance energy systems, see the applicable codes VdTÜV and 1466/AGFW FW 510. A heat transfer medium containing mineral oils, or any type of lubricant containing mineral oil can have extremely negative effects on

the source apparatus and usually lead to the disintegration of EPDM seals.

When using nitrite-free frost and corrosion resistance solutions with an ethylene glycol base, pay close attention to the details outlined in the manufacturers' documentation, particularly concerning concentration and specific additives.

– The thermostatic valve bodies can be used with all HEIMEIER thermostatic





heads and thermal or motorized actuators. Tune components appropriately to guarantee maximum safety.

When using actuators from other manufacturers, make sure that the pressure power is appropriate for thermostatic valve bodies with soft sealing valve discs.

Thermostatic valve bodies

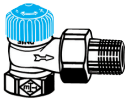
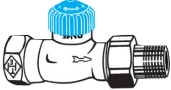
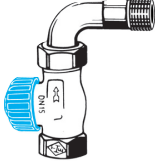
with particularly low resistance

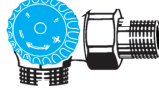
Article numbers

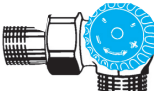
Structure	NW	k _v -value [m ³ /h] P-band [K]			k _{vs} - value [m ³ /h]	Gunmetal nickel-plated Art. no.
		1.0	2.0	3.0		
Angle 	ET 10 (3/8")	0.46	0.92	1.23	2.30	2241-01.000
	ET 15 (1/2")	0.46	0.92	1.23	3.10	2241-02.000
	ET 20 (3/4")	0.70	1.35	1.90	5.70	2241-03.000
	ET 25 (1")	0.70	1.35	1.90	5.70	2201-04.000
	ET 32 (1 1/4")	0.80	1.60	2.35	6.70	2201-05.000
Straight 	DT 10 (3/8")	0.46	0.92	1.23	1.80	2242-01.000
	DT 15 (1/2")	0.46	0.92	1.23	2.50	2242-02.000
	DT 20 (3/4")	0.70	1.35	1.90	4.50	2242-03.000
	DT 25 (1")	0.70	1.35	1.90	5.70	2202-04.000
	DT 32 (1 1/4")	0.80	1.60	2.35	6.70	2202-05.000
Straight  with bended nipple	DT 15 (1/2")	0.46	0.92	1.23	2.50	2244-02.000
Axial 	AT 10 (3/8")	0.46	0.92	1.23	1.80	2245-01.000
	AT 15 (1/2")	0.46	0.92	1.23	2.50	2245-02.000
Double angle  Connection to the radiator left	WET 10 (3/8")	0.46	0.92	1.23	1.50	2341-01.000
	WET 15 (1/2")	0.46	0.92	1.23	1.85	2341-02.000
Double angle with male thread G 3/4  Connection to radiator left	WET 15 (1/2")	0.46	0.92	1.23	1.85	2343-02.000
Double angle  Connection to the radiator right	WET 10 (3/8")	0.46	0.92	1.23	1.50	2340-01.000
	WET 15 (1/2")	0.46	0.92	1.23	1.85	2340-02.000
Double angle with male thread G 3/4  Connection to the radiator right	WET 15 (1/2")	0.46	0.92	1.23	1.85	2342-02.000

Permitted operating temperature TB 120°C (248°F), with cover, TB 90°C (194°F). Permitted operating pressure PB 10 bar, low pressure steam 110°C (230°F) / 0.5 bar. NW 25/NW 32 black protection cap. Compression fittings, see accessories.

Thermostatic valve bodies for reversed flow direction

Description



The HEIMEIER thermostatic valve bodies for reversed flow direction with black protection cap can be used with all HEIMEIER thermostatic heads and actuators.

The stainless spindle is equipped with a double O-ring sealing. The outer O-ring is replaceable under pressure. The complete thermostatic insert can be replaced with the HEIMEIER fitting tool without draining off the system.

The body, which is made of corrosion-resistant gunmetal with a female thread, is designed for connection to a threaded pipe, or in conjunction with compression fittings, for connection to copper or precision steel pipes.

For HEIMEIER valve bodies, use only the accompanying, labelled HEIMEIER compression fitting (label e. g. 15 THE).

Assembly

Thermostatic valve body for reversed flow direction

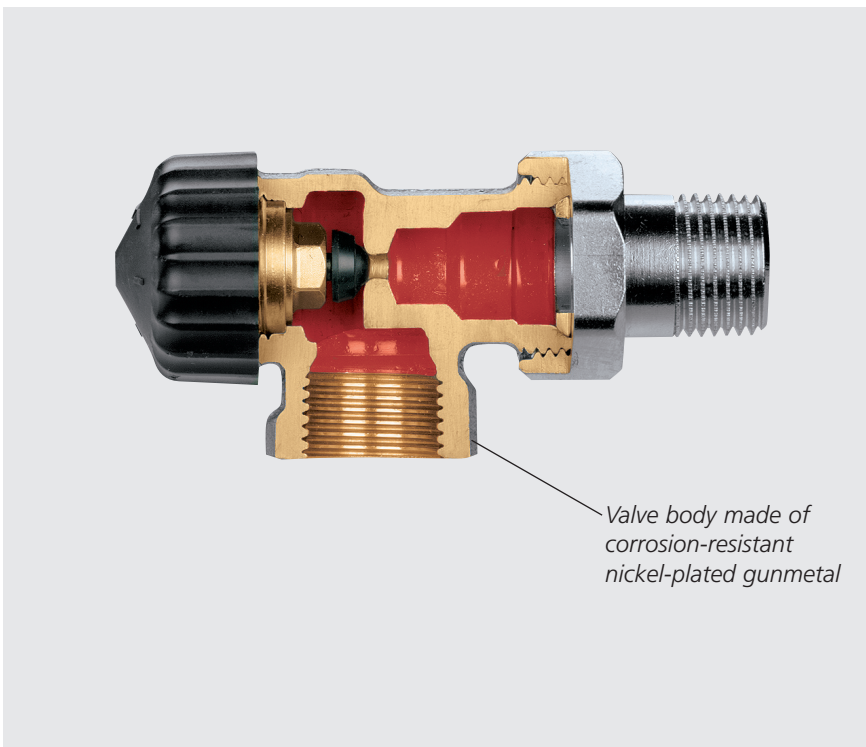

- Stainless spindle with double O-ring sealing
- Body made of nickel-plated corrosion-free gunmetal
- Thermostatic insert can be replaced under pressure

Thermostatic valve bodies for reversed flow direction

Application

The HEIMEIER thermostatic valve bodies for reversed flow direction can be used in two-pipe pump heating systems for interchangeable supply and return flow (hammering noises).

If any questions arise regarding the increased or reduced output of the radiator in relation to through-flow, ask the radiator manufacturer for information.

The valve bodies can be mounted into the return flow connection of radiators in a raised position or tall radiators.

This makes the thermostatic head more easily accessible.

Corresponding to the standards EnEV and DIN V 4701-10, they can be designed with a control difference from 1 K to 2 K thus enabling a broad flow spectrum (for technical data/diagrams, see pages 28 and 29).

A hydraulic balance, which is an additional requirement, can be reached with the appropriate lockshields e. g. HEIMEIER Regulux.

To ensure low-noise operation, experience shows that the differential pressure over the thermostatic valves should not exceed approx. 0.2 bar. If when planning a system it is clear that high differential pressures occur in the partial load area, differential pressure control devices, e. g. the TA STAP differential pressure-controller or the Hydrolux overflow valve should be used.

Sample application

Thermostatic valve in the reverse flow connection

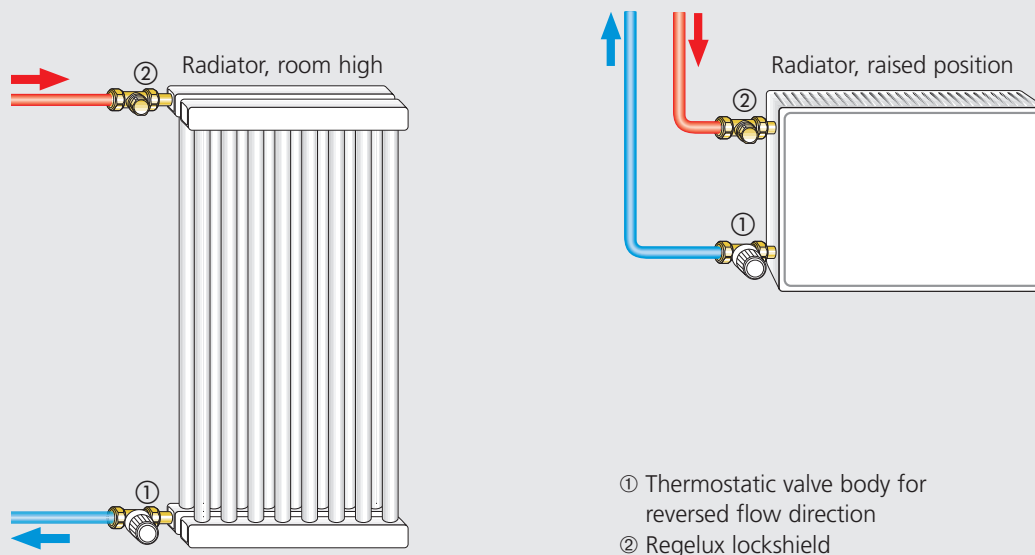

Notes

– To avoid damage and the formation of scale deposit in the hot water heating system, the composition of the heat transfer medium should be in accordance with the VDI guideline 2035. For industrial and long-distance heating systems, see the applicable codes VdTÜV and 1466/AGFW FW 510. A heat transfer medium containing mineral oils, or any type of lubricant containing mineral oil can have extremely negative effects on

the source apparatus and usually lead to the disintegration of EPDM seals.

When using nitrite-free frost and corrosion resistance solutions with an ethylene glycol base, pay close attention to the details outlined in the manufacturers' documentation, particularly concerning concentration and specific additives.

– The thermostatic valve bodies can be used with all HEIMEIER thermostatic

heads and thermal or motorized actuators. Tune components appropriately to guarantee maximum safety.

When using actuators from other manufacturers, make sure that the pressure power is appropriate for thermostatic valve bodies with soft sealing valve discs.

Thermostatic valve bodies for reversed flow direction

Article numbers

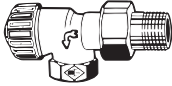
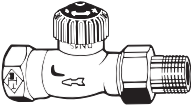
Structure	NW	k _v -value [m ³ /h] P-band [K]			k _{vs} - value [m ³ /h]	Gunmetal nickel-plated Art. no.
		1.0	2.0	3.0		
Angle 	ET 10 (3/8")	0.25	0.49	0.66	1.25	9101-01.000 9101-02.000
	ET 15 (1/2")	0.25	0.49	0.66	1.35	
Straight 	DT 10 (3/8")	0.25	0.49	0.66	1.25	9102-01.000 9102-02.000
	DT 15 (1/2")	0.25	0.49	0.66	1.35	

Permitted operating temperature TB 120°C (248°F). Permitted operating pressure PB 10 bar, low pressure steam 110°C (230°F) / 0.5 bar.
Compression fittings, see accessories.

Thermostatic three-way valve bodies with automatic bypass control

Description

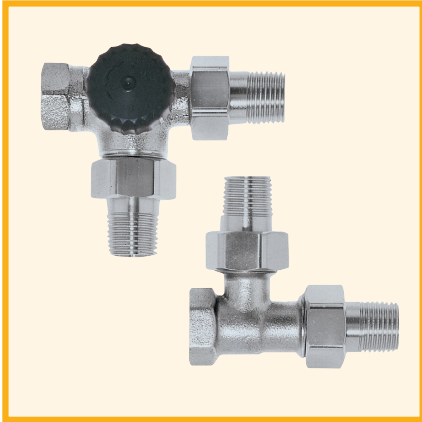

The HEIMEIER thermostatic three-way-valve bodies with automatic bypass control and black protection cap can be used with all HEIMEIER thermostatic heads and actuators.

The bypass can be connected with the corresponding bypass T-piece on the radiator return.

Models for the connection on the radiator, left or right.

The stainless spindle is equipped with a double O-ring sealing. The outer O-ring is replaceable under pressure.

The body of the valve body, which is made of nickel-plated gunmetal, or the bypass T-piece, which is made of nickel-plated brass, is designed for connection to the threaded pipe or when used with compression fittings, for connection to copper or precision steel pipes.

For HEIMEIER valve bodies, use only the accompanying, labelled HEIMEIER compression fitting (label e. g. 15 THE).

Bypass connection with:
Ø 15 compression fitting,
NW 15 (1/2") threaded nipple or
Ø 15 soldered nipple.

Assembly

Thermostatic three-way valve body

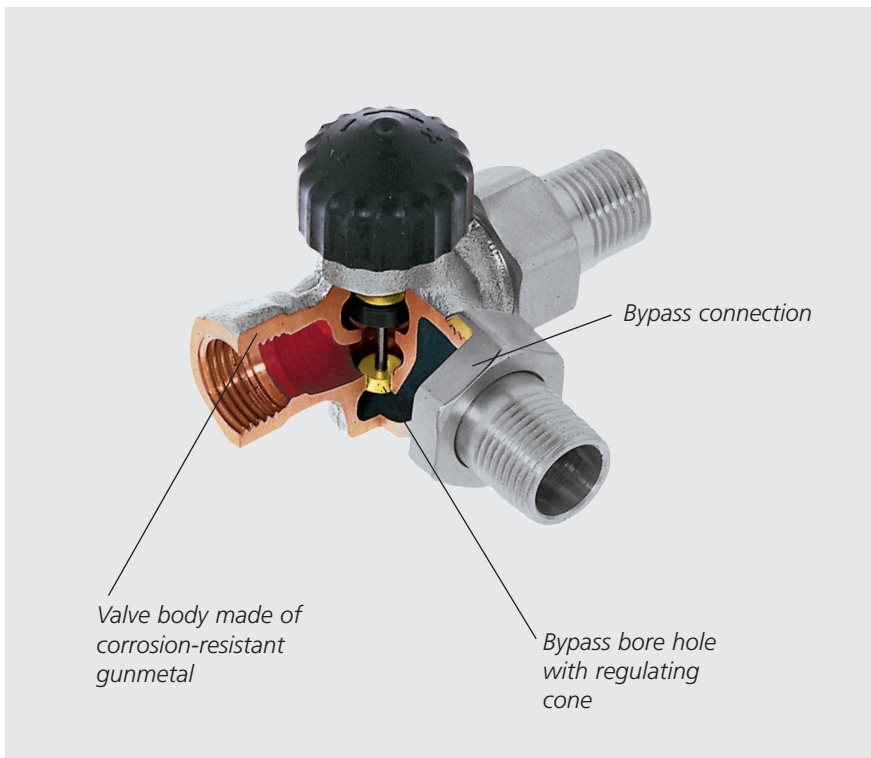

- Stainless spindle with double O-ring sealing
- Body made of corrosion-resistant gunmetal
- Outer O-ring can be replaced while under pressure

Thermostatic three-way valve bodies with automatic bypass control



Application

The HEIMEIER thermostatic three-way valve bodies are used in single and two-pipe pump heating systems.

When almost all valves are closed at the same time, additional pressures build up in the heating system. If the HEIMEIER three-way valve intercepts the radiator flow, the bypass for the return flow is fully opened. Additional pressures are avoided and the pressure is kept almost constant. The total flow of the HEIMEIER three-way valve body has a kv value of

1.45 m³/h (see curve 2 in the diagram on page 36). 1 three-way valve is allocated for each heating circuit. For normal systems, for almost every 18 kW.

For wall-mounted gas fired heaters with a set minimum circulatory flow level, the number of three-way valves should be calculated from curve 2 (see diagram on page 36). Curve 1, or the kv values of the different p-bands, acts as a pressure loss definition for the set radiator mass flow.

Corresponding to the standards EnEV and DIN V 4701-10, the valve bodies can be designed with a control difference from 1 K to 2 K thus enabling a broad flow spectrum (for technical data/diagrams, see page 36).

For the valve installation, select the point furthest away from the pump. The ideal installation sites are the hallway or the bathroom.

Sample application

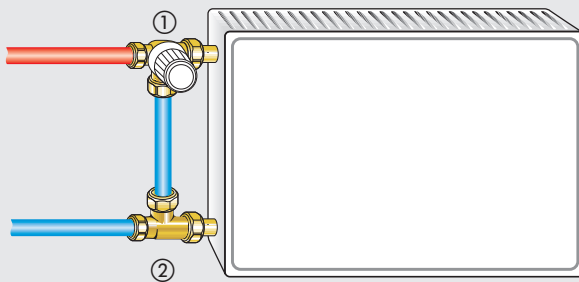

- ① Thermostatic three-way valve body
- ② Bypass T-piece

Notes

– To avoid damage and the formation of scale deposit in the hot water heating system, the composition of the heat transfer medium should be in accordance with the VDI guideline 2035. For industrial and long-distance energy systems, see the applicable codes VdTÜV and 1466/AGFW FW 510. A heat transfer medium containing mineral oils, or any type of lubricant containing mineral oil can have extremely negative effects on the source apparatus and usually leads to the disintegration of EPDM seals.

When using nitrite-free frost and corrosion resistance solutions with an ethylene glycol base, pay close attention to the details outlined in the manufacturers' documentation, particularly details concerning concentration and specific additives.

– The thermostatic valve bodies can be used with all HEIMEIER thermostatic heads and thermal or motorized actuators. Tune components appropriately to guarantee maximum safety.

When using actuators from other manufacturers, make sure that the pressure power is appropriate for thermostatic valve bodies with soft sealing valve discs.

Thermostatic three-way valve bodies with automatic bypass control

Article numbers

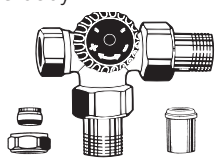
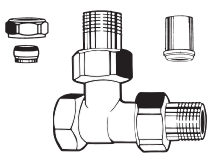
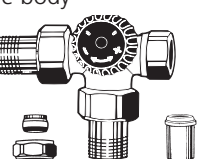
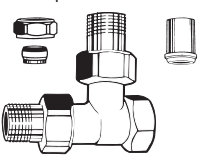
Structure	Bypass connection	NW	Radiator k_v -value [m ³ /h] P-band [K]			k_v -value total ²⁾ [m ³ /h]	Three-way valve body Art. no.	Corresponding bypass T-piece Art. no.
			1.0	2.0 ¹⁾	3.0			
Connection on the radiator left Thermostatic three-way valve body  Bypass T-piece 	Ø 15 Compression fitting	15 (1/2")	0.38	0.73	0.98	1.45	Gunmetal nickel-plated 4149-02.000	Brass nickel-plated 4156-02.000
	NW 15 (1/2") Screwed nipple	15 (1/2")	0.38	0.73	0.98	1.45	Gunmetal nickel-plated 4151-02.000	Brass nickel-plated 4154-02.000
	Ø 15 Soldered nipple	15 (1/2")	0.38	0.73	0.98	1.45	Gunmetal nickel-plated 4153-02.000	Brass nickel-plated 4155-02.000
Connection to the radiator right Thermostatic three-way valve body  Bypass T-piece 	Ø 15 Compression fitting	15 (1/2")	0.38	0.73	0.98	1.45	Gunmetal nickel-plated 4148-02.000	Brass nickel-plated 4156-02.000
	NW 15 (1/2") Screwed nipple	15 (1/2")	0.38	0.73	0.98	1.45	Gunmetal nickel-plated 4150-02.000	Brass nickel-plated 4154-02.000
	Ø 15 Soldered nipple	15 (1/2")	0.38	0.73	0.98	1.45	Gunmetal nickel-plated 4152-02.000	Brass nickel-plated 4155-02.000

Permitted operating temperature TB 120°C (248°F). Permitted Operating pressure PB 10 bar.

¹⁾ Distribution ratio at 2.0 K approx. 50%.

²⁾ Total k_v -value for radiator and bypass.





Compression fittings, see accessories.

Accessories



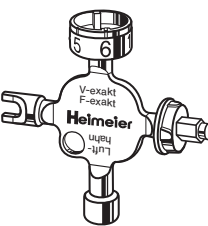

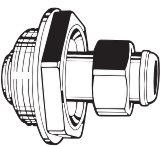
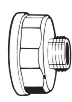
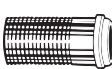
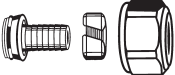

Figure	Description	Art. no.	
	Cover 2-part, plastic, white RAL 9016 , for thermostatic valve bodies with female thread and press connection (not for valve bodies with reduced lengths).	NW valve 10 (3/8") 15 (1/2")	Angle form 1361-01.553 1361-02.553
		10 (3/8") 15 (1/2")	Straight form 1362-01.553 1362-02.553
	Handwheel for all HEIMEIER thermostatic valve bodies. Max. medium temperature 100°C (212°F).	white RAL 9016	with locking ring 2001-00.325
		white RAL 9016 chrome-plated	with direct connection 1303-01.325 1303-10.325
	Fitting tool complete with case, box spanner and replacement seals, for replacing thermostatic inserts without draining off the heating system (for NW 10 to NW 20). Refer also to the assembly and operating instructions. Replacement seals		9721-00.000
			9721-00.514
	Box spanner SW 19 for loosening and tightening the thermostatic inserts. Refer also to the assembly and operating instructions.		2001-00.258
	Theft protection for thermostatic head K. By security ring. Refer also to the assembly and operating instructions.		6020-01.347
	Locking cap Brass, with seal, on the radiator side for thermostatic valves.	NW valve 10 (3/8") 15 (1/2") 20 (3/4")	2001-01.314 2001-02.314 2001-03.314
	Spindle extension for thermostatic valve bodies. Brass, nickel-plated Plastic, black	L [mm]	
		20	2201-20.700
		30	2201-30.700
		15	2001-15.700
30	2002-30.700		

Thermostatic valve bodies

Accessories

Illustration	Description	Art. no.
	Setting key for V-exakt and F-exakt. Refer also to the assembly and operating instructions.	3501-02.142
	Universal key as an alternative to the setting key art. no. 3501-02.142 for adjusting V-exakt/F-exakt. Also for thermostatic head B (temperature setting), Regulux lockshield, Vekolux double connection fitting and radiator air vent. Refer also to the assembly and operating instructions.	0530-01.433
	k_{VS}-diaphragm for mass flow restriction for Standard thermostatic valve bodies. Technical data, pages 29 and 31.	NW valve 10 (3/8") 15 (1/2") 2001-01.514 2001-02.514
	Ventilux Radiator compensation fitting with continuously adjustable screw nipple. With this fitting, old valves of different supply and return pipe lengths can easily be replaced. Double O-ring sealing. Permitted operating pressure PB 10 bar. Permitted operating temperature TB 120°C (248°F). Adjustable to 35 mm. Radiator connection NW 32 (1 1/4"). High static pressures can lead to displacement of the compensation fitting. Secure pipes and radiators adequately. Ensure that stress-free installation is carried out.	NW valve 10 (3/8") 15 (1/2") 20 (3/4") 2001-01.600 2001-02.600 2001-03.600 NW valve 10 (3/8") 15 (1/2") 20 (3/4") 2002-01.600 2002-02.600 2002-03.600 Right-handed thread Left-handed thread
	Reducing piece for replacing old valves with valve bodies with smaller nominal widths. Brass nickel-plated.	Rp 3/4 x R 1/2 2201-32.044 Rp 1 x R 1/2 2201-42.044 Rp 1 x R 3/4 2201-43.044 Rp 1 1/4 x R 1/2 2201-52.044 Rp 1 1/4 x R 3/4 2201-53.044
	Threaded nipple for length compensation. Brass nickel-plated.	Total length 47.0 mm R 3/8 2201-01.010 54.0 mm R 1/2 2201-02.010 52.5 mm R 3/4 2201-03.010
	Threaded nipple Standard length Continuous thread for reduced lengths. Brass nickel-plated.	Total length 27.0 mm R 3/8 2202-01.010 31.5 mm R 1/2 2202-02.010 32.5 mm R 3/4 2202-03.010

Accessories

Illustration	Description			Art. no.
	Compression fitting for copper or precision steel pipes. Metal-to-metal joint. Brass nickel-plated. Female thread connection Rp $\frac{3}{8}$ –Rp $\frac{3}{4}$. Support sleeves should be used for a pipe wall thickness of 0.8–1 mm. Follow the specifications of the pipe manufacturer.	Ø Pipe	NW	
		12	10 ($\frac{3}{8}$ "	2201-12.351
		15	15 ($\frac{1}{2}$ "	2201-15.351
		16	15 ($\frac{1}{2}$ "	2201-16.351
		18	20 ($\frac{3}{4}$ "	2201-18.351
	Compression fitting for copper or precision steel pipes. Metal-to-metal joint. Brass nickel-plated. Male thread connection G $\frac{3}{4}$. Support sleeves should be used for a pipe wall thickness of 0.8–1 mm. Follow the specifications of the pipe manufacturer.	Ø Pipe		
		12		3831-12.351
		15		3831-15.351
		16		3831-16.351
	Support sleeve for copper or precision steel pipes with a wall thickness of 1 mm. Brass.	Ø Pipe	L	
		12	25.0	1300-12.170
		15	26.0	1300-15.170
		16	26.3	1300-16.170
	Compression fitting for copper or precision steel pipes. Soft sealed. Brass nickel plated. Male thread connection G $\frac{3}{4}$.	Ø Pipe		
		15		1313-15.351
		16		1313-16.351
	Compression fitting for plastic pipes. Brass nickel plated. Male thread connection G $\frac{3}{4}$.	Ø Pipe		
		14 x 2		1311-14.351
		16 x 2		1311-16.351
		17 x 2		1311-17.351
		18 x 2		1311-18.351
	Connection nipple for flat sealing valve bodies.	NW-valve	Ø Pipe	
	Threaded nipple	15 ($\frac{1}{2}$ "	$\frac{1}{2}$ "	4160-02.010
		20 ($\frac{3}{4}$ "	$\frac{3}{4}$ "	4160-03.010
	Soldered nipple	15 ($\frac{1}{2}$ "	15	4160-15.039
		15 ($\frac{1}{2}$ "	16	4160-16.039
		15 ($\frac{1}{2}$ "	18	4160-18.039
		20 ($\frac{3}{4}$ "	22	4160-22.039
	Welded nipple	15 ($\frac{1}{2}$ "	$\frac{1}{2}$ "	4160-02.043
		20 ($\frac{3}{4}$ "	$\frac{3}{4}$ "	4160-03.043

Thermostatic valve bodies

Accessories

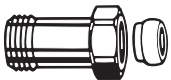
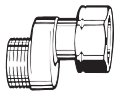
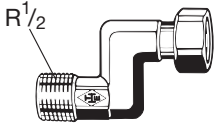
Illustration	Description	L [mm]	NW valve	Art. no.
	Double connection fitting G 3/4 x R 1/2. For clamping plastic, copper, precision steel or multi-layer pipes. Brass nickel-plated.	26		1321-12.083
	Double nipple G 3/4 x G 3/4. Both sides for clamping plastic, copper, precision steel or multi-layer pipes. Brass nickel-plated.			1321-03.081
	Length adjustment fitting G 3/4 x G 3/4. For clamping plastic, copper, precision steel or multi-layer pipes. For valves with male thread connection G 3/4. Brass nickel-plated.	25 50		9713-02.354 9714-02.354
	S-connection G 3/4 x G 3/4. For compensating different pipe distances, e. g. when replacing old single pipe valves. Note flow direction! Brass nickel-plated. Axial distance 11.5 mm. Total length 43 mm.			1351-02.362
	S-connection For compensating different connection dimensions when replacing radiators. Gunmetal nickel-plated. Axial distance 26 mm. Total length 68 mm.		10 (3/8") 15 (1/2") 20 (3/4")	1353-01.362 1353-02.362 1353-03.362

Thermostatic valve bodies



Thermostatic inserts











T label
on the valve body
no connecting thread

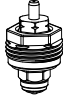

Connecting thread
for the thermostatic
head on the valve body



Boss
marking

Replacement inserts	Art. no.	Thermostatic valve bodies	Reversed flow direction	Male thread on both sides
	Standard , stuffing box without coloured label, from the end of 1982 for NW 10, 15 2001-02.300 for NW 20 2001-03.300 for NW 25 2001-04.299 for NW 32 2001-05.299	2001, 2002, 2201, 2202, 2215, 2216, 2225, 2310, 2311 2001, 2002, 2201, 2202, 2215, 2216 2001, 2002, 2201, 2202 2001, 2002, 2201, 2202	9002, 9002	2072, 2312, 2313 2235 2072
	Special insert for inverse direction of flow with reversed supply and return pipes 2002-24.300 For thermostatic valve bodies: – Standard from end of 1982 , NW 10, 15 – V-exakt / F-exakt from 1994 , NW 10–20	2001, 2002, 2201, 2202, 2215, 2216, 2225, 2310, 2311, 3501, 3502, 3505, 3506, 3510, 3511, 3512, 3513, 3514, 3515, 3516, 3430, 3431, 3432		2072, 2312, 2313 2235 3533, 3534
Retrofitting/replacement inserts	Art. no.	Thermostatic valve bodies	Reversed flow direction	Male thread on both sides
	V-exakt with precision presetting, for thermostatic valve bodies with boss marking, from 1994 for NW 10, 15 3501-02.300 (also for NW 20 V-exakt valve bodies)	3501, 3502, 3505, 3506, 3510, 3511, 3512, 3513, 3514, 3515, 3516		3533, 3534
	F-exakt with finest presetting, for thermostatic valve bodies with boss marking, from 1994 , nickel-plated stuffing box for NW 10, 15 3420-02.300	3430, 3431, 3432		
 supplied with thermostatic head K	Retro S – Set with precision presetting, for thermostatic valve bodies „Standard“ without boss marking, with connecting thread on the valve body, from end of 1982 for NW 15 from end of 1982-1994 3500-12.800 for NW 20 from end of 1982 3500-13.800 Flow rates correspond to V-exakt; diagrammes see page 32.	2001, 2002, 2201, 2202, 2215, 2216, 2225, 2310, 2311 2001, 2002, 2201, 2202, 2215, 2216		2072, 2312, 2313 2235 2072
Replacement inserts	Art. no.	Thermostatic valve bodies	Reversed flow direction	Male thread on both sides
	Presetting , stuffing box with white label, from 1985 to 1994 for NW 10, 15, 20 2101-02.299	2101, 2102, 2111, 2112, 2135, 2170, 2171	9200, 9201, 9204, 9205	2172, 2173
	Gravity, until end 1984 Stuffing box without coloured label for NW 15 2241-02.299 from 1985 Stuffing box with blue label for NW 10, 15 2340-02.299 without coloured label for NW 20 (until '05), DN 32 2001-05.299 for NW 20 (since '05), DN 25 2001-04.299	2241, 2242, 2245, 2340, 2341 2241, 2242, 2245, 2340, 2341 2241, 2242, 2201, 2202 2201, 2202	9101, 9102	2076, 2342, 2343
	Thermostatic three-way inserts for NW 15 4140-02.300	4138, 4139, 4140, 4141, 4142, 4143, 4148, 4149, 4150, 4151, 4152, 4153		
Retrofitting/replacement inserts	Art. no.	Mikrotherm manual valves	Thermostatic valve bodies	
	from February 1985 Stuffing box with black label for NW 10, 15 1302-02.300 without coloured label for NW 20 2001-03.300	With connector thread on the body 0101, 0102 0101, 0102	1302, 1304, 1308, 1322, 1324, 1328, 2074	
	Old model, to February 1985 NW 10, 15 4101-02.300 NW 20 4101-03.300 NW 25 2001-04.299 NW 32 2001-05.299	With T label 0101, 0102 0101, 0102 0101, 0102 0101, 0102		

Thermostatic valve bodies

Technical data

Standard

Diagram NW 10 (3/8") to NW 20 (3/4"), valve body with thermostatic head

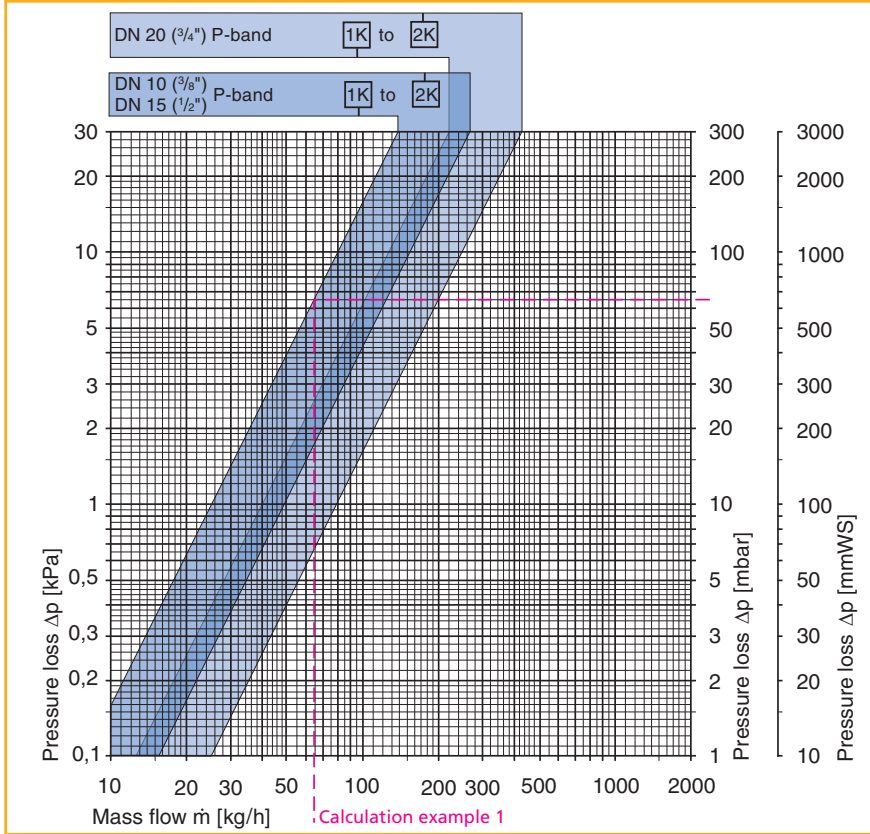
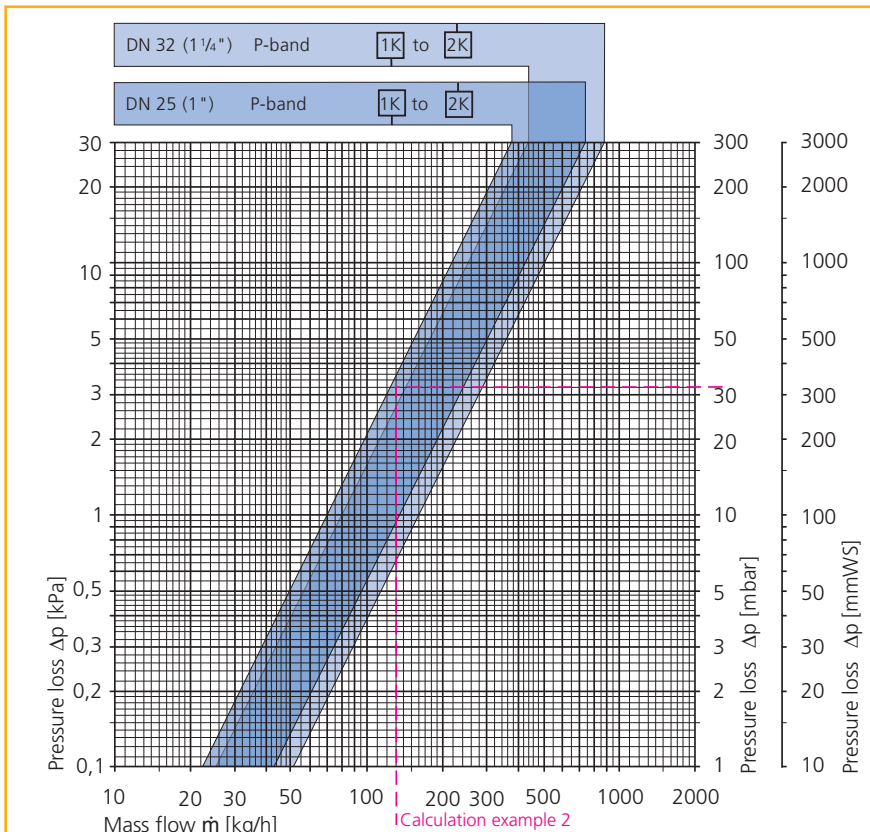

Diagram NW 25 (1") and NW 32 (1 1/4"), valve body with thermostatic head



Technical data

Standard

Valve body with thermostatic head	k_V -value [m ³ /h]					k_{VS} -value [m ³ /h]		Permitted operating temperature TB ²⁾ [°C]	Permitted operating pressure PB [bar]	Permitted differential pressure, during which the valve is kept closed Δp [bar]		
	P-band [K]					ET DT AT	WET			Th.-head	EMO T/NC EMOtec/NC EMO 1/3 EMO EIB/LON	EMO T/NO EMOtec/NO
	1.0	1.5	2.0	2.5	3.0							
NW 10 (3/8") ¹⁾ ET (angle) DT (straight) WET (double angle) AT (axial)	0.25	0.37	0.49	0.58	0.66	1.25	1.10	120	10	1.00	3.50	3.50
NW 15 (1/2") ¹⁾ ET (angle) DT (straight) WET (double angle) AT (axial)	0.25	0.37	0.49	0.58	0.66	1.35	1.15					
NW 20 (3/4") ET (angle) DT (straight)	0.40	0.60	0.79	0.98	1.26	2.50		120	10	1.00	2.00	3.50
NW 25 (1") ET (angle) DT (straight)	0.70	1.04	1.35	1.65	1.90	5.70		120	10	0.25	0.80	1.60
NW 32 (1 1/4") ET (angle) DT (straight)	0.80	1.10	1.60	2.00	2.35	6.70		120	10	0.25	0.50	1.00
NW 10 (3/8") Data with kvs diaphragm for with ¹⁾ labelled valves	0.22	0.29	0.33	0.36	0.38	0.41	0.41	120	10	1.00	3.50	3.50
NW 15 (1/2") Data with kvs diaphragm for with ¹⁾ labelled valves	0.25	0.37	0.47	0.54	0.59	0.73	0.73	120	10			

²⁾ with protection cap or actuator 100 °C (212 °F), with cover 90 °C (194 °F), with press connection 110 °C (230 °F).

Technical data/diagram NW 10/NW 15 only apply to thermostatic valve bodies for reversed flow direction.

k_V -diaphragms, see page 24.

Sample calculation 1

Target:	Pressure loss of Standard thermostatic valve body NW 15 with a p-band of 1 K	
Given:	Heat flow	$\dot{Q} = 1135 \text{ W}$
	Temperature spread	$\Delta t = 15 \text{ K (65/50°C)}$
Solution:	Mass flow	$\dot{m} = \frac{\dot{Q}}{c \cdot \Delta t} = \frac{1135}{1.163 \cdot 15} = 65 \text{ kg/h}$
	Pressure loss from diagram	$\Delta p_V = 65 \text{ mbar}$

Sample calculation 2

Target:	Appropriate Standard thermostatic valve body	
Given:	Heat flow	$\dot{Q} = 2270 \text{ W}$
	Temperature spread	$\Delta t = 15 \text{ K (70/55°C)}$
	Pressure loss, thermostatic valve	$\Delta p_V = 32 \text{ mbar}$
Solution:	Mass flow	$\dot{m} = \frac{\dot{Q}}{c \cdot \Delta t} = \frac{3840}{1.163 \cdot 15} = 130 \text{ kg/h}$
	Standard thermostatic valve body from diagram: NW 25 (1")	

$$c_V = \frac{k_V}{0.86}$$

$$k_V = c_V \cdot 0.86$$

Thermostatic valve bodies

Technical data

Standard – flat sealing

Diagram NW 15 (1/2") [k_{VS} 1.35] and NW 15 (1/2") [k_{VS} 1.70], valve body with thermostatic head

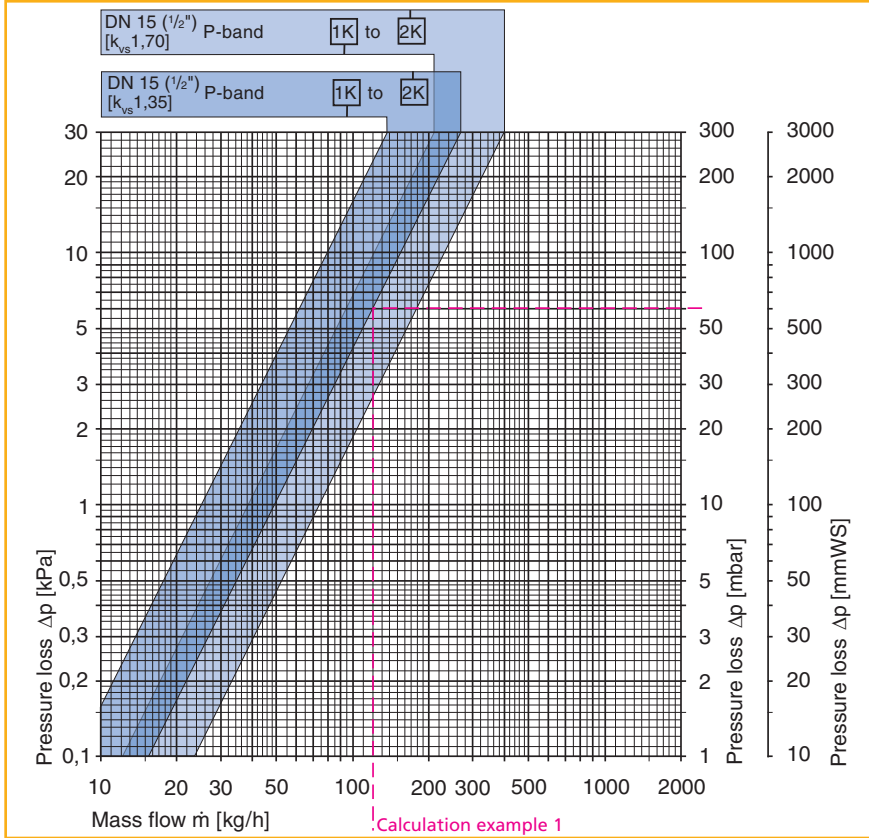
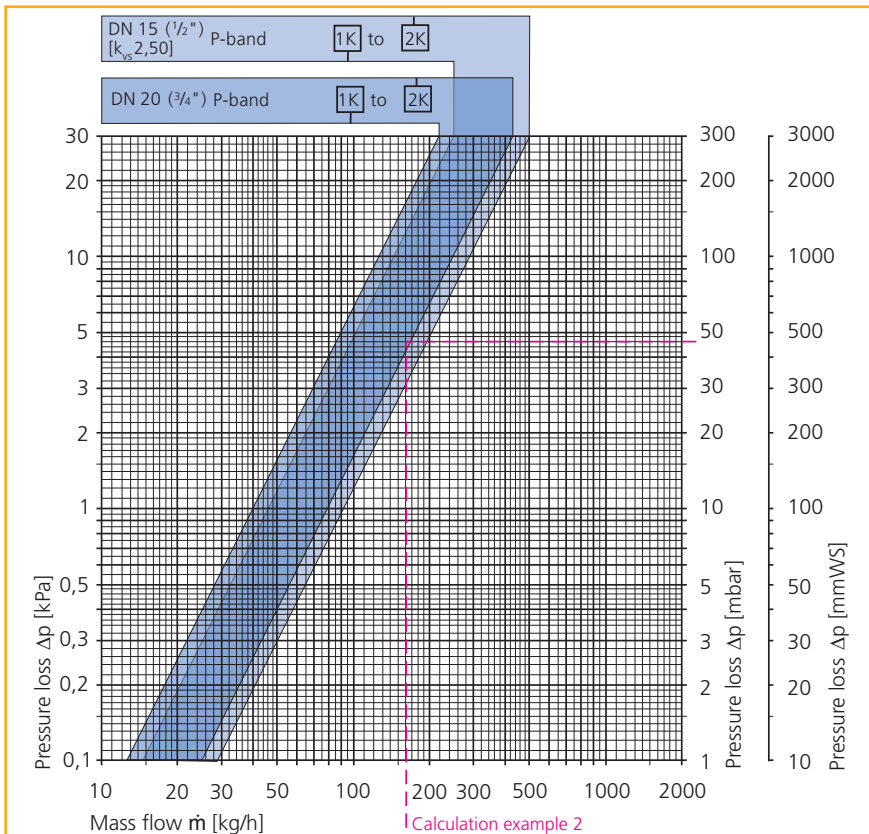

Diagram NW 15 (1/2") [k_{VS} 2.50] and NW 20 (3/4"), valve body with thermostatic head



Technical data

Standard – flat sealing

Valve body with thermostatic head	k _V -value [m ³ /h]					k _{VS} -value [m ³ /h]	Permitted operating temperature TB ²⁾ [°C]	Permitted operating pressure PB [bar]	Permitted differential pressure, during which the valve is kept closed Δp [bar]		
	P-band [K]								Th.-head	EMO T/NC EMOtec/NC EMO 1/3 EMO EIB/LON	EMO T/NO EMOtec/NO
	1.0	1.5	2.0	2.5	3.0						
NW 15 (1/2") ¹⁾ flat sealing (straight)	0.25	0.37	0.49	0.58	0.66	1.35	120	10	1.00	3.50	3.50
NW 15 (1/2") flat sealing (straight)	0.38	0.59	0.73	0.95	1.10	1.70	120	10	1.00	2.70	3.50
NW 15 (1/2") flat sealing (straight)	0.46	0.70	0.92	1.05	1.23	2.50	120	10	0.60	1.50	3.00
NW 20 (3/4") flat sealing (straight)	0.40	0.60	0.79	0.98	1.26	2.50	120	10	1.00	2.00	3.50
NW 15 (1/2") data with k _{VS} diaphragm for with ¹⁾ labelled valve	0.25	0.37	0.47	0.54	0.59	0.73	120	10	1.00	3.50	3.50

²⁾ With protection cap or actuator 100°C (212°F).
k_{VS}-diaphragm, see page 24.

Sample calculation 1

Target: Pressure loss, Standard thermostatic valve body – flat sealing, NW 15 [k_{VS} 1.35] with p-band 2 K

Given: Heat flow $\dot{Q} = 2095 \text{ W}$
Temperature spread $\Delta t = 15 \text{ K (70/55°C)}$

Solution: Mass flow $\dot{m} = \frac{\dot{Q}}{c \cdot \Delta t} = \frac{2095}{1.163 \cdot 15} = 120 \text{ kg/h}$
Pressure loss from diagram $\Delta p_V = 60 \text{ mbar}$

Sample calculation 2

Target: Appropriate Standard thermostatic valve – flat sealing

Given: Heat flow $\dot{Q} = 2790 \text{ W}$
Temperature spread $\Delta t = 15 \text{ K (65/50°C)}$
Pressure loss thermostatic valve $\Delta p_V = 46 \text{ mbar}$

Solution: Mass flow $\dot{m} = \frac{\dot{Q}}{c \cdot \Delta t} = \frac{2790}{1.163 \cdot 15} = 160 \text{ kg/h}$
Standard thermostatic valve body – flat sealing from diagram: NW 15 (1/2") [k_{VS} 2.50] or NW 20 (3/4")

$$c_V = \frac{k_V}{0.86}$$

$$k_V = c_V \cdot 0.86$$

Thermostatic valve bodies

Technical data

V-exakt

Diagram, valve body with thermostatic head

P-band [xp] min. 0,4 K to **max. 1,0 K**

P-band [xp] min. 0,5 K to **max. 2,0 K**

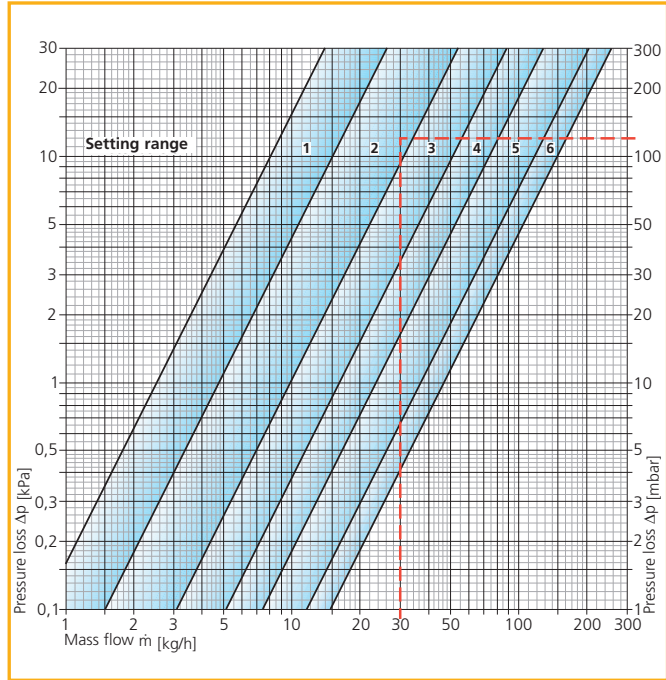
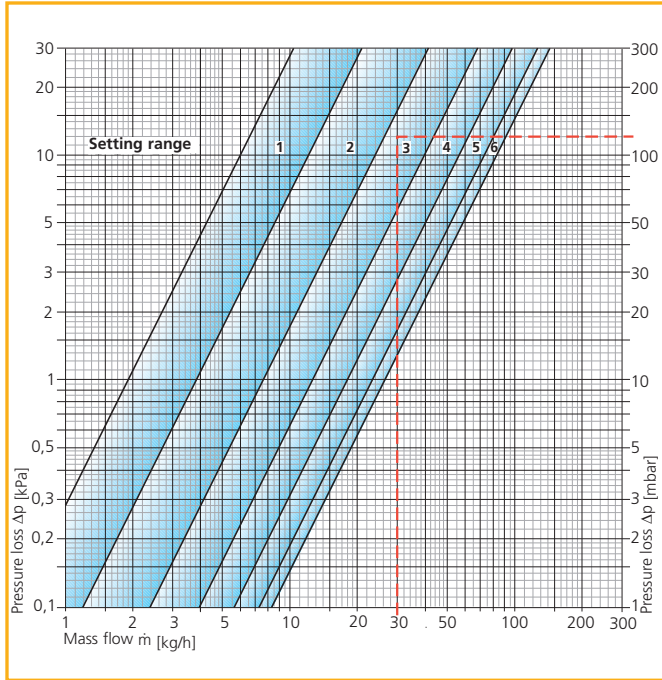

Valve body with thermostatic head			Precision presetting						Permitted operating temperature TB*) [°C]	Permitted operating pressure PB [bar]	Permitted differential pressure, during which the valve is kept closed Δp [bar]		
			1	2	3	4	5	6			Th.-head	EMO T/NC EMOtec/NC EMO 1/3 EMO EIB/LON	EMO T/NO EMOtec/NO
DN 10/15 (3/8" / 1/2") ET, DT, AT, WET DN 20 (3/4") ET, DT	P-band xp min. 0.4 K to max. 1.0 K	min. k _V -value	0.019	>0.038	>0.076	>0.126	>0.180	>0.234	120	10	4.0	3.5	3.5
		max.	0.038	0.076	0.126	0.180	0.234	0.262					
	P-band xp min. 0.5 K to max. 2.0 K	min. k _V -value	0.025	>0.047	>0.098	>0.161	>0.234	>0.364					
		max.	0.047	0.098	0.161	0.234	0.364	0.468					
		k _{VS} -value [m³/h]	0.054	0.104	0.174	0.247	0.459	0.730					
		Flow-tolerance ± [%]	20	15	10	8	7	6					

*) with protection cap or actuator 100 °C (212 °F), with cover 90 °C (194 °F), with press connection 110 °C (230 °F).

k_V-value in [m³/h]

Sample calculation

Target: Setting range

Given: Heat flow $\dot{Q} = 525 \text{ W}$
 Temperature spread $\Delta t = 15 \text{ K (65/50 °C)}$
 Pressure loss, thermostatic valve $\Delta p_v = 120 \text{ mbar}$

$$c_v = \frac{k_v}{0.86}$$

Solution: Mass flow $\dot{m} = \frac{\dot{Q}}{c \cdot \Delta t} = \frac{525}{1.163 \cdot 15} = 30 \text{ kg/h}$

$$k_v = c_v \cdot 0.86$$

Setting range from Diagram:
 With P-band **max. 1.0 K**: 3
 With P-band **max. 2.0 K**: 2

Technical data

F-exakt

Diagram, valve body with thermostatic head

P-band [xp] min. 0,3 K to **max. 1,0 K**

P-band [xp] min. 0,4 K to **max. 2,0 K**

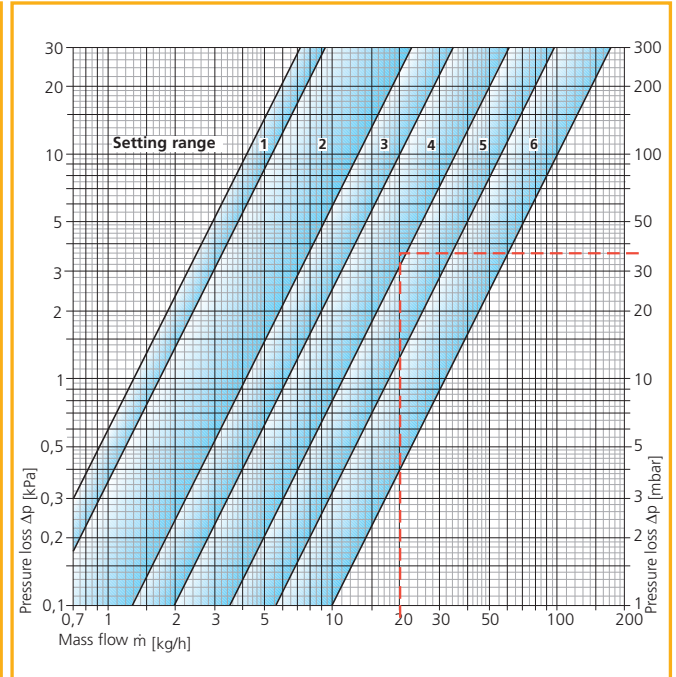
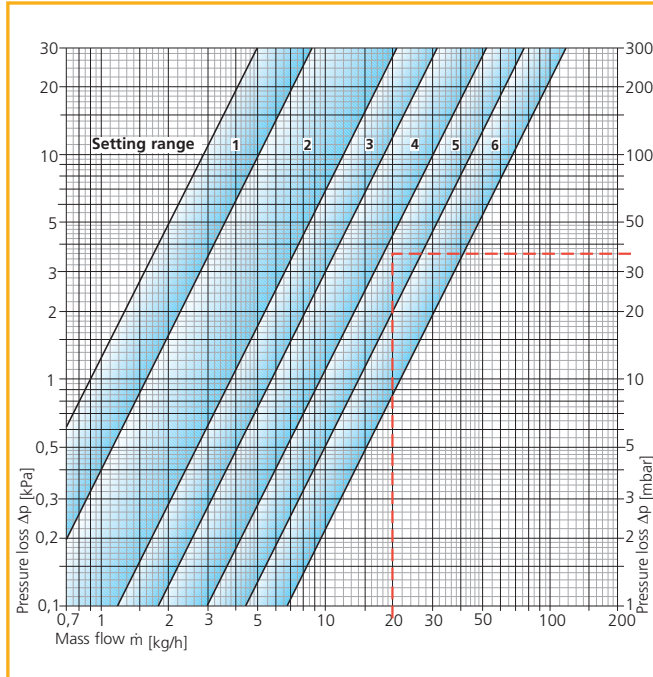

Valve body with thermostatic head			Finest presetting						Permitted operating temperature TB*) [°C]	Permitted operating pressure PB [bar]	Permitted differential pressure, during which the valve is kept closed Δp [bar]		
			1	2	3	4	5	6			Th.-head	EMO T/ NC EMOtec/NC EMO 1/3 EMO EIB/LON	EMO T/ NO EMOtec/NO
DN 10/15 (3/8" / 1/2") ET, DT, AT	P-band xp min. 0.3 K to max. 1.0 K	min. k _V -value max.	0.009 0.016	>0.016 0.038	>0.038 0.057	>0.057 0.095	>0.095 0.141	>0.141 0.215	120	10	4.0	3.5	3.5
	P-band xp min. 0.4 K to max. 2.0 K	min. k _V -value max.	0.013 0.017	>0.017 0.041	>0.041 0.063	>0.063 0.111	>0.111 0.177	>0.177 0.316					
		k _{VS} -value [m ³ /h]	0.017	0.041	0.063	0.114	0.187	0.350					
		Flow-tolerance ± [%]	30	25	20	15	10	8					

*) with protection cap or actuator 100°C (212°F), with cover 90°C (194°F).

k_V-value in [m³/h]

Sample calculation

Target: Setting range

Given: Heat flow $\dot{Q} = 350 \text{ W}$
 Temperature spread $\Delta t = 15 \text{ K (65/50 °C)}$
 Pressure loss, thermostatic valve $\Delta p_V = 36 \text{ mbar}$

$$c_V = \frac{k_V}{0.86}$$

$$k_V = c_V \cdot 0.86$$

Solution: Mass flow $\dot{m} = \frac{\dot{Q}}{c \cdot \Delta t} = \frac{350}{1.163 \cdot 15} = 20 \text{ kg/h}$

Setting range from Diagram:
 With P-band **max. 1.0 K**: 5
 With P-band **max. 2.0 K**: 4

Thermostatic valve bodies

Technical data

with particularly low resistance

Diagram NW 10 (3/8") to NW 20 (3/4"), valve body with thermostatic head

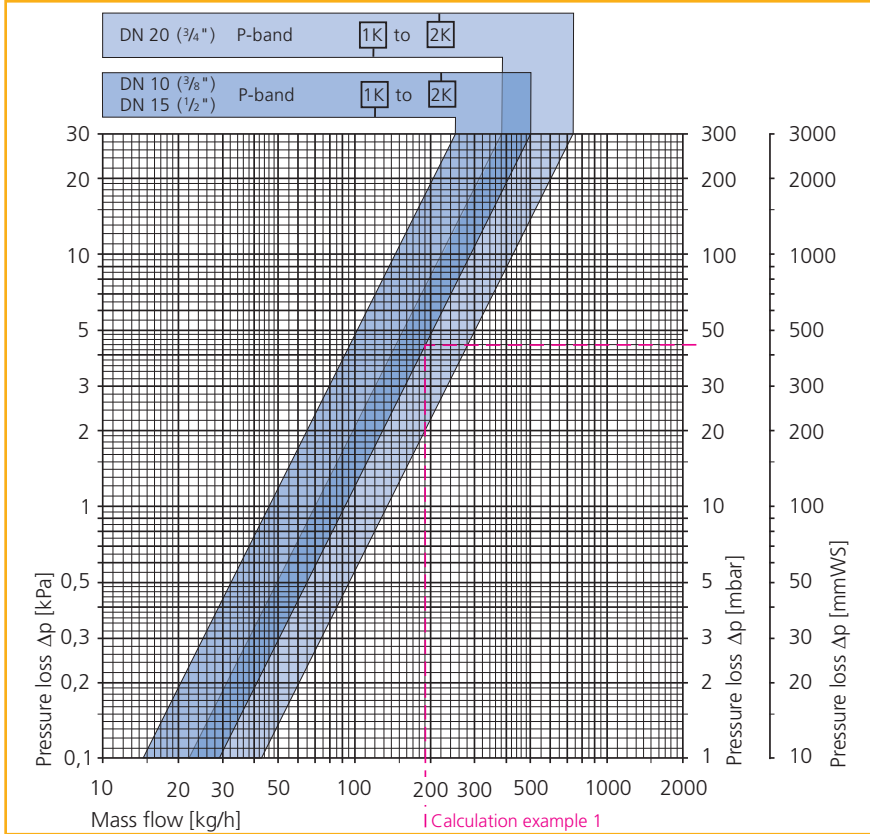
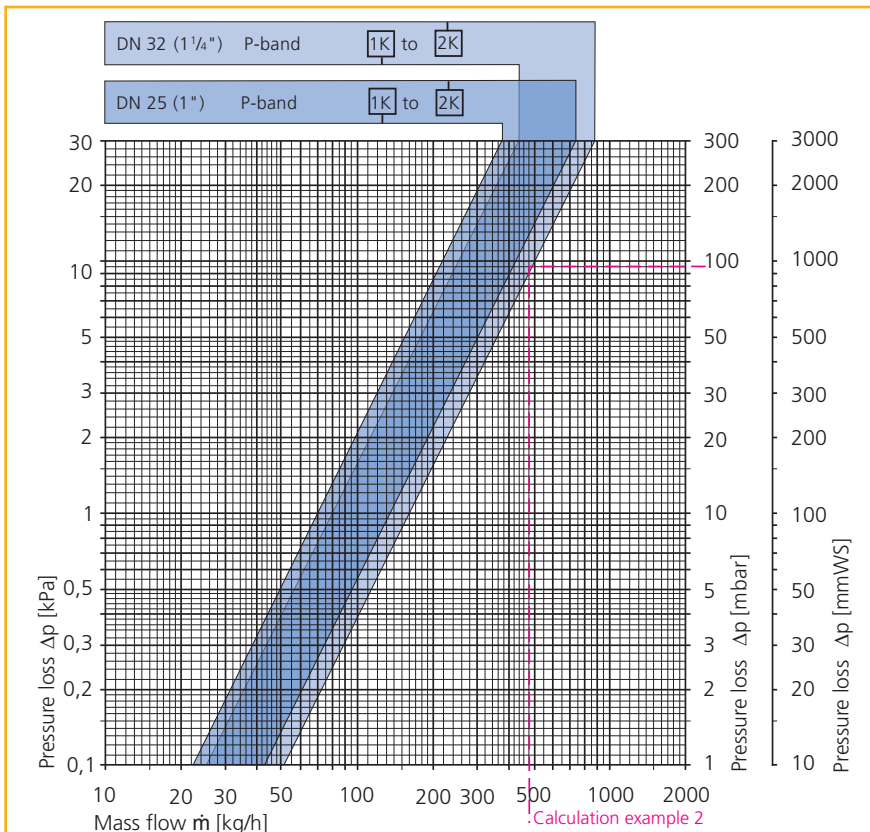

Diagram NW 25 (1") and NW 32 (1 1/4"), valve body with thermostatic head



Technical data

with particularly low resistance

Valve body with Thermostatic head			k _V -value [m ³ /h]					k _{VS} -value [m ³ /h]			Permitted operating temperature TB *) [°C]	Permitted operating pressure PB [bar]	Permitted differential pressure, during which the valve is kept closed Δp [bar]		
			P-band [K]					ET	DT AT	WET			Th.-head	EMO T/NC EMOtec/NC EMO 1/3 EMO EIB/LON	EMO T/NO EMOtec/NO
			1.0	1.5	2.0	2.5	3.0								
DN 10 (3/8")	ET (angle) DT (straight)	WET (double angle) AT (axial)	0.46	0.70	0.92	1.05	1.23	2.30	1.80	1.50	120	10	0.60	1.50	3.00
DN 15 (1/2")	ET (angle) DT (straight)	WET (double angle) AT (axial)	0.46	0.70	0.92	1.05	1.23	3.10	2.50	1.85					
DN 20 (3/4")	ET (angle) DT (straight)		0.70	1.04	1.35	1.65	1.90	5.70	4.50		120	10	0.25	0.50	1.00
DN 25 (1")	ET (angle) DT (straight)		0.70	1.04	1.35	1.65	1.90	5.70	5.70		120	10	0.25	0.80	1.60
DN 32 (1 1/4")	ET (angle) DT (straight)		0.80	1.10	1.60	2.00	2.35	6.70	6.70		120	10	0.25	0.50	1.00

*) with protection cap or actuator 100°C (212°F), with cover 90°C (194°F).

Sample calculation 1

Target:	Pressure loss, thermostatic valve body with particularly low resistance NW 15 with p-band 2 K	
Given:	Heat flow	$\dot{Q} = 2210 \text{ W}$
	Temperature spread	$\Delta t = 10 \text{ K (55/45°C)}$
Solution:	Mass flow	$\dot{m} = \frac{\dot{Q}}{c \cdot \Delta t} = \frac{2210}{1.63 \cdot 10} = 190 \text{ kg/h}$
	Pressure loss from diagram	$\Delta p_V = 44 \text{ mbar}$

Sample calculation 2

Target:	Appropriate thermostatic valve body with particularly low resistance	
Given:	Heat flow	$\dot{Q} = 8375 \text{ W}$
	Temperature spread	$\Delta t = 15 \text{ K (70/55°C)}$
	Pressure loss, thermostatic valve	$\Delta p_V = 95 \text{ mbar}$
Solution:	Mass flow	$\dot{m} = \frac{\dot{Q}}{c \cdot \Delta t} = \frac{8375}{1.163 \cdot 15} = 480 \text{ kg/h}$
	Thermostatic valve body with particularly low resistance from diagram: NW 32 (1 1/4")	

$$c_V = \frac{k_V}{0.86}$$

$$k_V = c_V \cdot 0.86$$

Thermostatic valve bodies

Technical data

Thermostatic three-way valve body

Diagram, three-way valve body with thermostatic head

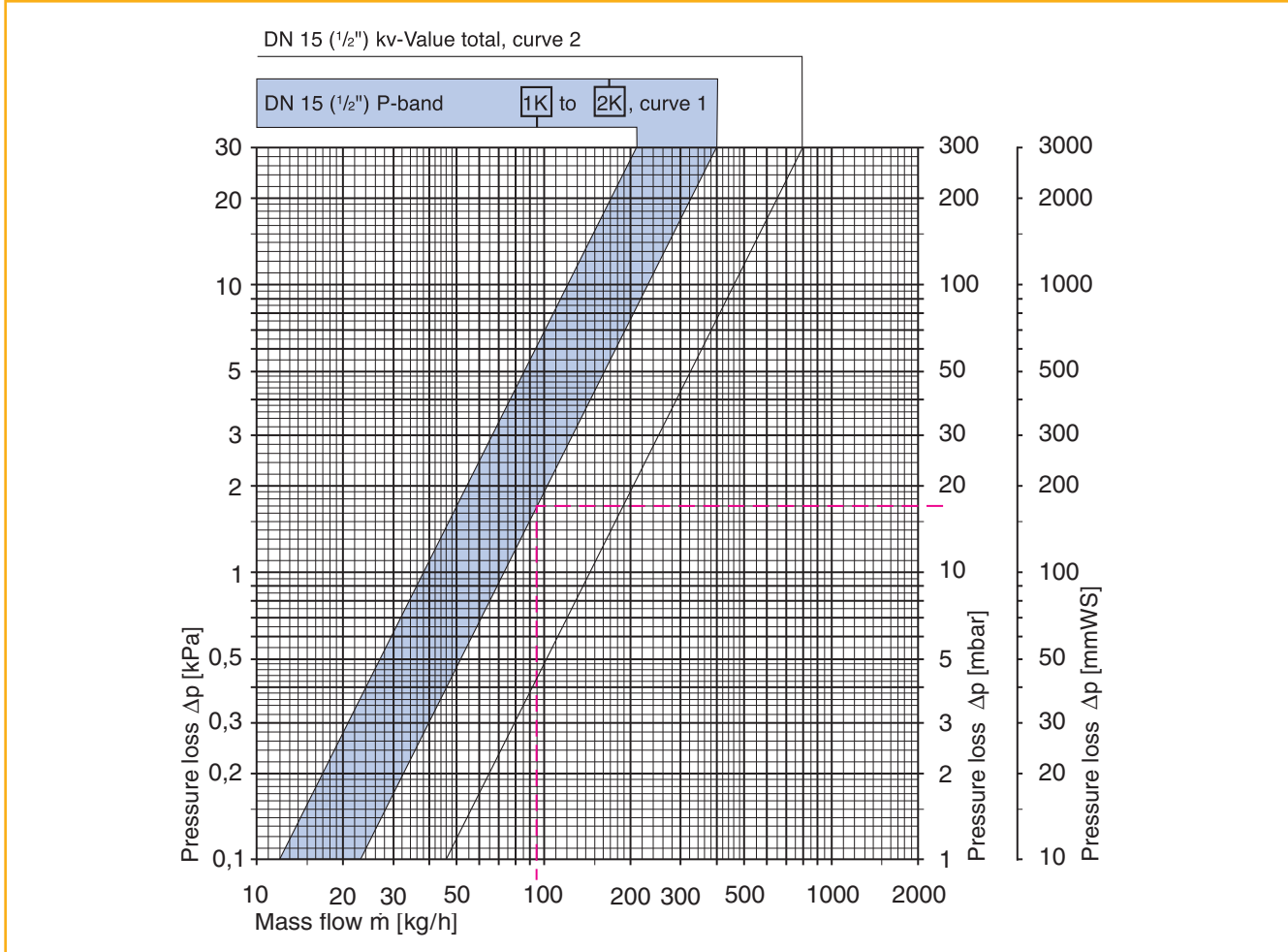

Three-way valve body with thermostatic head	k _v -value [m ³ /h]					k _v -value total ¹⁾ [m ³ /h]	Permitted operating temperature TB ²⁾ [°C]	Permitted operating pressure PB [bar]	Permitted differential pressure, during which the valve is kept closed Δp [bar] Th.-head	EMO T/NC EMOtec/NC EMO 1/3 EMO EIB/LON	EMO T/NO EMOtec/NO
	P-band [K]										
	1.0	1.5	2.0	2.5	3.0						
DN 15 (1/2") three way	0.38	0.55	0.73	0.87	0.98	1.45	120	10	1.0	2.0	3.5

1) total kv value for radiator and bypass.

2) With protection cap or actuator 100°C (212°F).

Sample calculation

Target: Pressure loss, thermostatic three-way valve body with p-band 2 K

$$c_v = \frac{k_v}{0.86}$$

Given: Heat flow $\dot{Q} = 1660 \text{ W}$
Temperature spread $\Delta t = 15 \text{ K (70/55°C)}$

$$k_v = c_v \cdot 0.86$$

Solution: Mass flow $\dot{m} = \frac{\dot{Q}}{c \cdot \Delta t} = \frac{1660}{1.163 \cdot 15} = 95 \text{ kg/h}$

Pressure loss from diagram $\Delta p_v = 17 \text{ mbar}$

Technical data

k_v and k_{vs} -value definition

Diagram

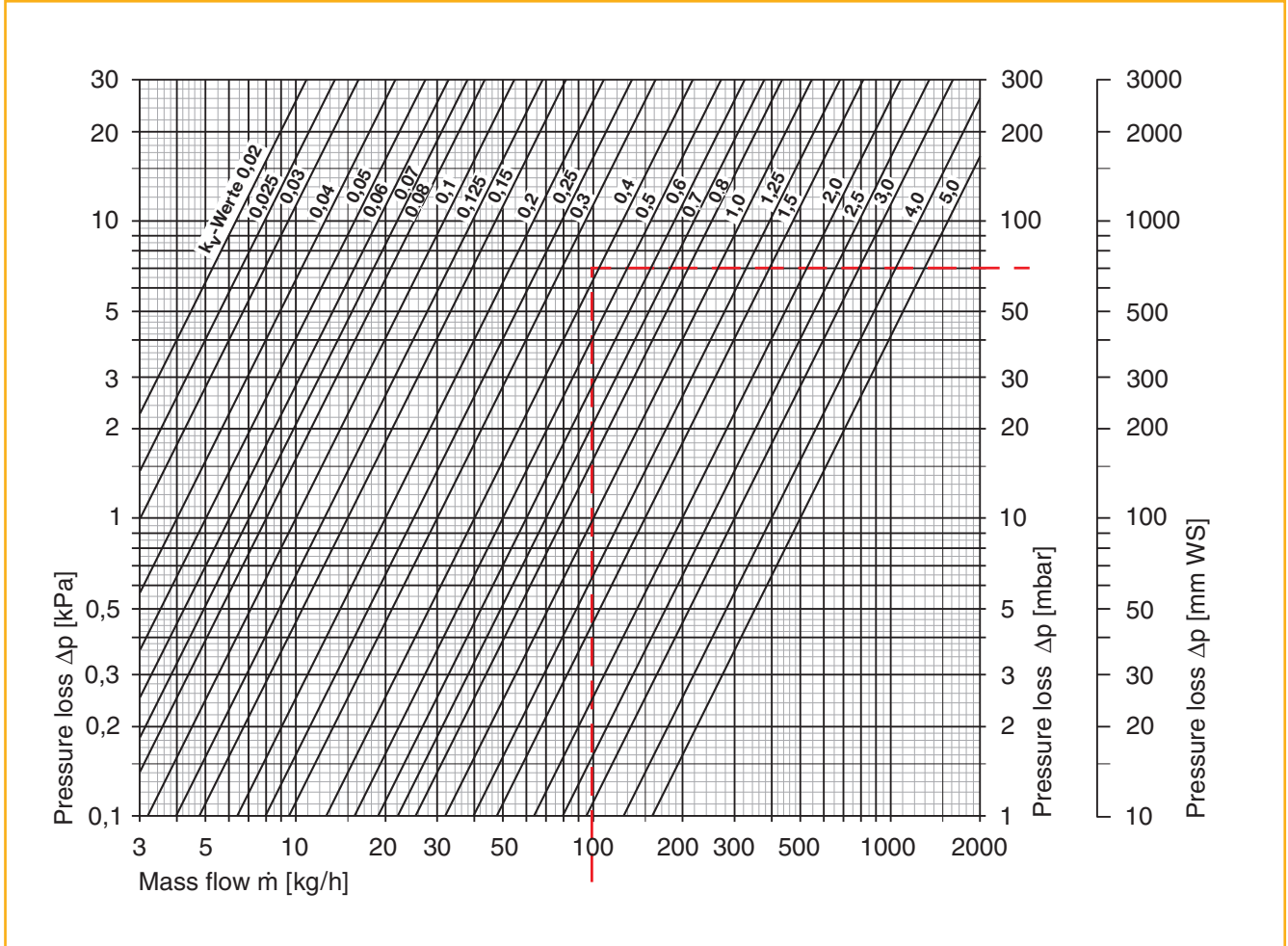

k_v -value and k_{vs} -value (c_v -value)

The k_v -value of a valve indicates the volume flow in m^3/h with a specific stroke (c_v -value) (p-band) and a pressure loss of 1.0 bar.

The k_{vs} -value indicates the volume flow when the valve is completely open.

Standard formula for water medium:

$$k_v = \frac{\dot{V}}{\sqrt{\Delta p}}$$

Symbols and units of measure

k_v/k_{vs} Valve characteristic in m^3/h

\dot{V} Volume flow in m^3/h

Δp Pressure loss in bar

$$c_v = \frac{k_v}{0.86}$$

$$k_v = c_v \cdot 0.86$$

Sample calculation

Target: k_v -value for valve definition

Given: Mass flow $\dot{m} = 98 \text{ kg/h}$
Pressure loss $\Delta p = 70 \text{ mbar}$

Solution: k_v -value from the diagram: $0.37 \text{ m}^3/h$

Selected: Standard
Thermostatic valve body
NW 15 ($1/2''$)
P-band 1.5 K

Technical data, see pages 28 and 29

Thermostatic valve bodies

Dimensions

ET thermostatic valve bodies
2201; 2241; 3431; 3511

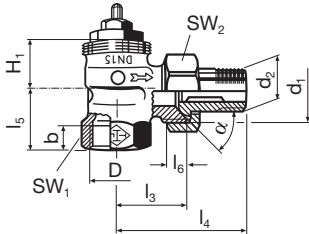

DT thermostatic valve bodies
2202; 2242; 3432; 3512

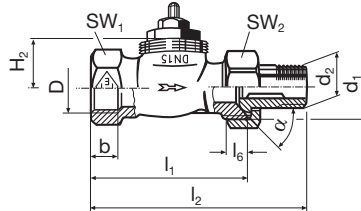

DT thermostatic valve bodies
with bended nipple
2206; 2244; 3556

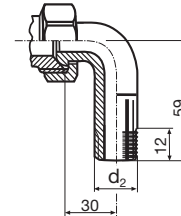

AT thermostatic valve bodies
2225; 2245; 3430; 3510

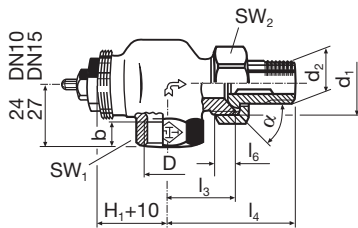

WET thermostatic valve bodies
2310/ 2311; 2340/2341; 3513/3514

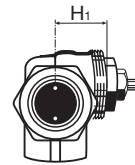
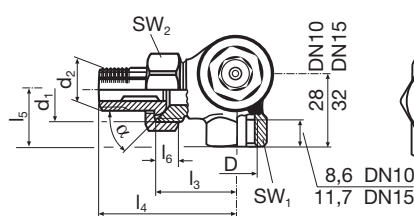

AT thermostatic valve bodies
2235; 3530

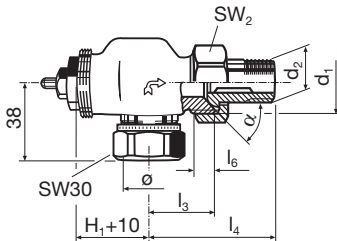

WET thermostatic valve bodies
2312/2313; 2342/2343; 3533/3534

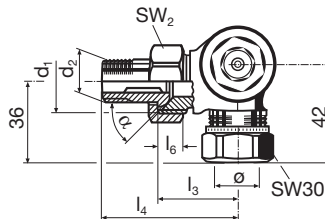

DT thermostatic valve bodies
flat sealing
2272; 2274; 2276

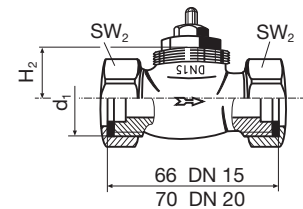

Thermostatic three-way valve bodies
4148; 4149; 4150; 4151; 4152; 4153

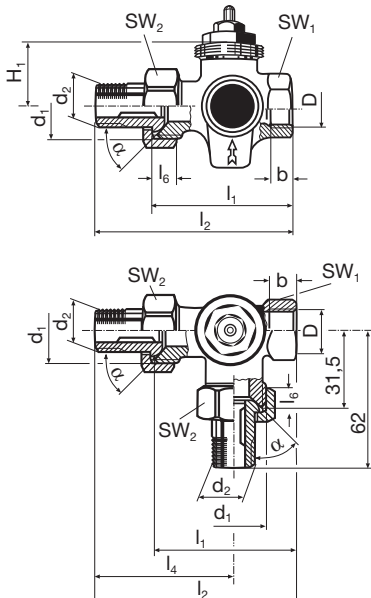

Bypass T-piece
4154; 4155; 4156

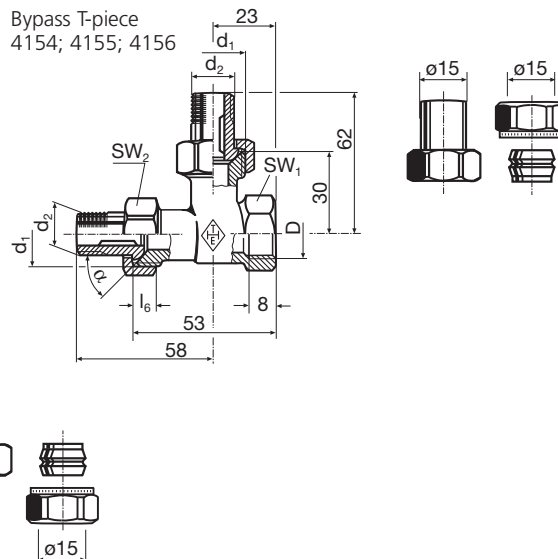

1 mm = 0.0394 inch

Dimensions

DT thermostatic valve body
reversed flow direction 9102

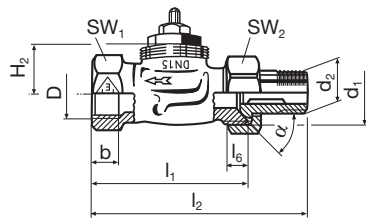

ET thermostatic valve body
reversed flow direction 9101

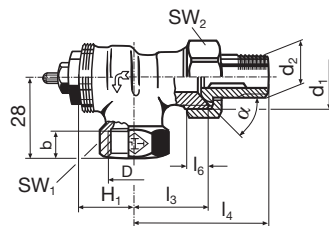

ET thermostatic valve body 9175

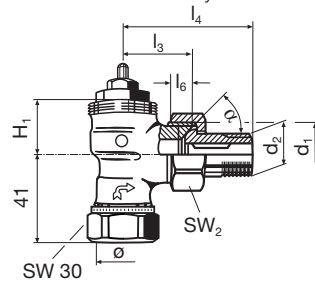

ET thermostatic valve body
with Press-Line connection with Viega SC-Contur 2291; 3517

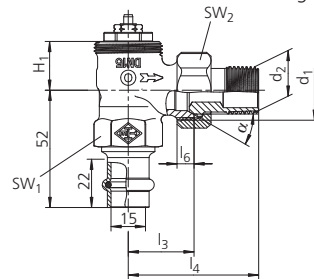

DT thermostatic valve body 1344

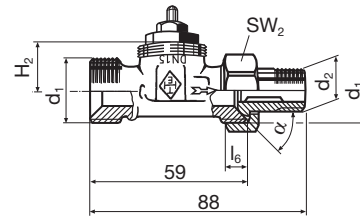

DT thermostatic valve body
reduced lengths 2216; 3516

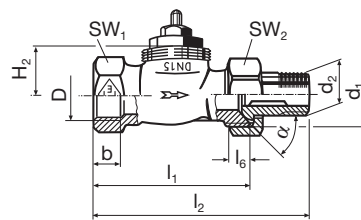

ET thermostatic valve body
reduced lengths 2215; 3515

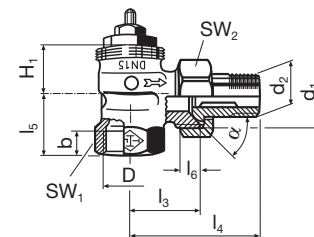

DT thermostatic valve body
with Press-Line connection with Viega SC-Contur 2292; 3518

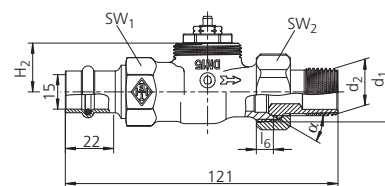

1 mm = 0.0394 inch

Thermostatic valve bodies

NW	D	b min.	d ₁	d ₂	l ₁ ±2	l ₂ ±2	l ₃ ±1	l ₄ ±1.5	l ₅ ±1.5	l ₆ min	α ±10°	Spanner opening SW ₁	Spanner opening SW ₂	H ₁ -0.5	H ₂ -0.5
10	Rp 3/8	10.1	G 5/8	R 3/8	59	85	26	52	22	6	70°	22	27	21.5	21.5
15	Rp 1/2	13.2	G 3/4	R 1/2	66	95	29	58	26	7		27	30	21.5	21.5
20	Rp 3/4	14.5	G 1	R 3/4	74	106	34	66	29	8		32	37	21.5	23.5
25	Rp 1	17	G 1 1/4	R 1	84	118	40	75	32.5	9		41	47	23	30.5
32	Rp 1 1/4	21	G 1 1/2	R 1 1/4	95	135	46	85	39	10		49	52	23	30.5

Thermostatic valve bodies with reduced lengths

NW	D	b min.	d ₁	d ₂	l ₁ ±0.5	l ₂ ±2	l ₃ ±0.5	l ₄ ±1.5	l ₅ ±0.5	l ₆ min	α ±1°	Spanner opening SW ₁	Spanner opening SW ₂	H ₁ -0.5	H ₂ -0.5
10	Rp 3/8	8	G 5/8	R 3/8	50	75	24	49	20	6	60°	22	27	21.5	21.5
15	Rp 1/2	9	G 3/4	R 1/2	55	82	26	53	23	7		27	30	21.5	21.5
20	Rp 3/4	10	G 1	R 3/4	65	98	30	63	26	8		32	37	21.5	23.5

Thermostatic valve bodies

Thermostatic heads and valve bodies



Certified and tested by KEYMARK
in accordance with DIN EN 215
(Series D and F)
KEYMARK symbol approval number 011-6T 0006

Thermostatic heads

Article numbers
2500-00.500
6000-00.500
6000-00.600
6001-00.500
6002-00.500
6005-00.500
6008-00.500
6010-00.500
6001-00.600
6002-00.600
6700-00.500
6850-00.500
7000-00.500

Thermostatic valve bodies, Series D

Article numbers		
NW 10	NW 15	NW 20
2201-01.000	2201-02.000	2201-03.000
2202-01.000	2202-02.000	2202-03.000
2241-01.000	2241-02.000	
2242-01.000	2242-02.000	
3431-01.000	3431-02.000	
3432-01.000	3432-02.000	
3511-01.000	3511-02.000	3511-03.000
3512-01.000	3512-02.000	3512-03.000

Thermostatic valve bodies, Series F

Article numbers		
NW 10	NW 15	NW 20
2215-01.000	2215-02.000	2215-03.000
2216-01.000	2216-02.000	2216-03.000
3515-01.000	3515-02.000	
3516-01.000	3516-02.000	

Thermostatic valve bodies

Article numbers		
NW 10	NW 15	NW 20
	2206-02.000	
	2244-02.000	
	2291-15.000	
	2292-15.000	
	3517-15.000	
	3518-15.000	



Theodor Heimeier Metallwerk GmbH
Postfach 1124, 59592 Erwitte, Germany
Telephone + 49 2943 891-0
Fax + 49 2943 891-100
www.heimeier.com